

Σ -7-Series AC Servo Drive

Σ -7S SERVOPACK with FT/EX Specification for Tracking Application Product Manual

Model: SGD7S-□□□A00□□□□F19□, -□□□A20□□□□F19□

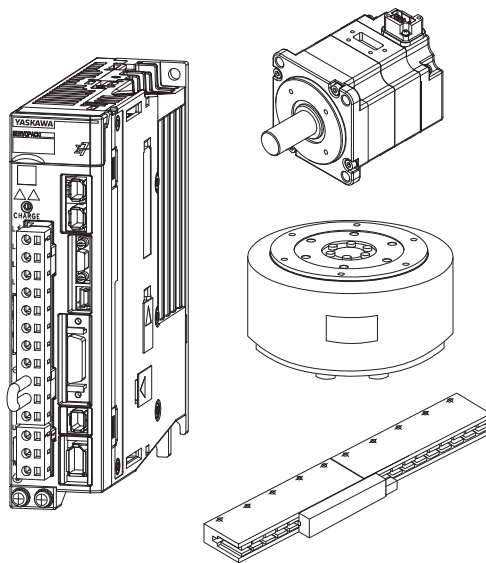

| | |
|--------------------------------------|---|
| Basic Information on SERVOPACKs | 1 |
| SERVOPACK Ratings and Specifications | 2 |
| Less-Deviation Control | 3 |
| Maintenance | 4 |
| Parameter Lists | 5 |

Copyright © 2015 YASKAWA ELECTRIC CORPORATION

All rights reserved. No part of this publication may be reproduced, stored in a retrieval system, or transmitted, in any form, or by any means, mechanical, electronic, photocopying, recording, or otherwise, without the prior written permission of Yaskawa. No patent liability is assumed with respect to the use of the information contained herein. Moreover, because Yaskawa is constantly striving to improve its high-quality products, the information contained in this manual is subject to change without notice. Every precaution has been taken in the preparation of this manual. Nevertheless, Yaskawa assumes no responsibility for errors or omissions. Neither is any liability assumed for damages resulting from the use of the information contained in this publication.

About this Manual

This manual describes the tracking application option for Σ -7-Series AC Servo Drive Σ -7S SERVOPACKs.

Read and understand this manual to ensure correct usage of the Σ -7-Series AC Servo Drives.

Keep this manual in a safe place so that it can be referred to whenever necessary.

Outline of Manual

The contents of the chapters of this manual are described in the following table.

When you use the SERVOPACK, read this manual and the relevant product manual given in the following table.

| Item | This Manual | Σ -7-Series AC Servo Drive Σ -7S SERVOPACK Product Manual | |
|---|--|---|--|
| | | SERVOPACKs with Analog Voltage/Pulse Train References (Manual No.: SIEP S800001 26) | SERVOPACKs with MECHATROLINK-III Communications References (Manual No.: SIEP S800001 28) |
| Basic Information on SERVOPACKs | The Σ -7 Series | – | 1.1 |
| | Product Introduction | 1.1 | – |
| | Interpreting the Nameplates | – | 1.2 |
| | Part Names | – | 1.3 |
| | Model Designations | – | 1.4 |
| | Combinations of SERVOPACKs and Servomotors | – | 1.5 |
| | Functions | 1.4 | – |
| | SigmaWin+ | 1.5 | – |
| Selecting a SERVOPACK | Ratings | 2.1 | – |
| | SERVOPACK Overload Protection Characteristics | 2.2 | – |
| | Specifications | 2.3 | – |
| | Block Diagrams | – | 2.2 |
| | External Dimensions | – | 2.3 |
| | Examples of Standard Connections between SERVOPACKs and Peripheral Devices | – | 2.4 |
| SERVOPACK Installation | – | | Chapter 3 |
| Wiring and Connecting SERVOPACKs | – | | Chapter 4 |
| Basic Functions That Require Setting before Operation | – | | Chapter 5 |
| Application Functions | – | | Chapter 6 |
| Trial Operation and Actual Operation | – | | Chapter 7 |
| Tuning | – | | Chapter 8 |

Continued on next page.

Continued from previous page.

| Item | | This Manual | Σ-7-Series AC Servo Drive Σ-7S SERVOPACK Product Manual | |
|--|--|--------------|---|--|
| | | | SERVOPACKs with Analog Voltage/Pulse Train References (Manual No.: SIEP S800001 26) | SERVOPACKs with MECHATROLINK-III Communications References (Manual No.: SIEP S800001 28) |
| Monitoring | Monitoring Product Information | – | 9.1 | |
| | Monitoring SERVO-PACK Status | – | 9.2 | |
| | Monitoring Machine Operation Status and Signal Waveforms | 3.6 | – | |
| | Monitoring Product Life | – | 9.4 | |
| Fully-Closed Loop Control | | – | Chapter 10 | |
| Safety Functions | | – | Chapter 11 | |
| Less-Deviation Control | Introduction | 3.1 | – | |
| | Restrictions | 3.2 | – | |
| | Adjusting Less-Deviation Control 2 | 3.3 | – | |
| | Adjusting Less-Deviation Control 1 | 3.4 | – | |
| | Reference Compensation | 3.5 | – | |
| Maintenance | Inspections and Part Replacement | – | 12.1 | |
| | Alarm Displays | 4.1.1, 4.2.1 | – | |
| | List of Alarms | 4.1.2, 4.2.2 | – | |
| | Troubleshooting Alarms | 4.1.3, 4.2.3 | – | |
| | Warning Displays | 4.1.4, 4.2.4 | – | |
| | List of Warnings | 4.1.5, 4.2.5 | – | |
| | Troubleshooting Warnings | 4.1.6, 4.2.6 | – | |
| Panel Displays and Panel Operator Procedures | | – | Chapter 13 | – |
| Parameter Lists | Interpreting the Parameter Lists | 5.1.1, 5.2.1 | – | |
| | List of Parameters and List of Servo Parameters | 5.1.2, 5.2.2 | – | |
| | List of MECHATROLINK-III Common Parameters | 5.2.3 | – | |
| | Parameter Recording Table | 5.1.3, 5.2.4 | – | |
| Appendices | | – | Chapter 15 | Chapter 14 |

Related Documents

The relationships between the documents that are related to the Servo Drives are shown in the following figure. The numbers in the figure correspond to the numbers in the table on the following pages. Refer to these documents as required.

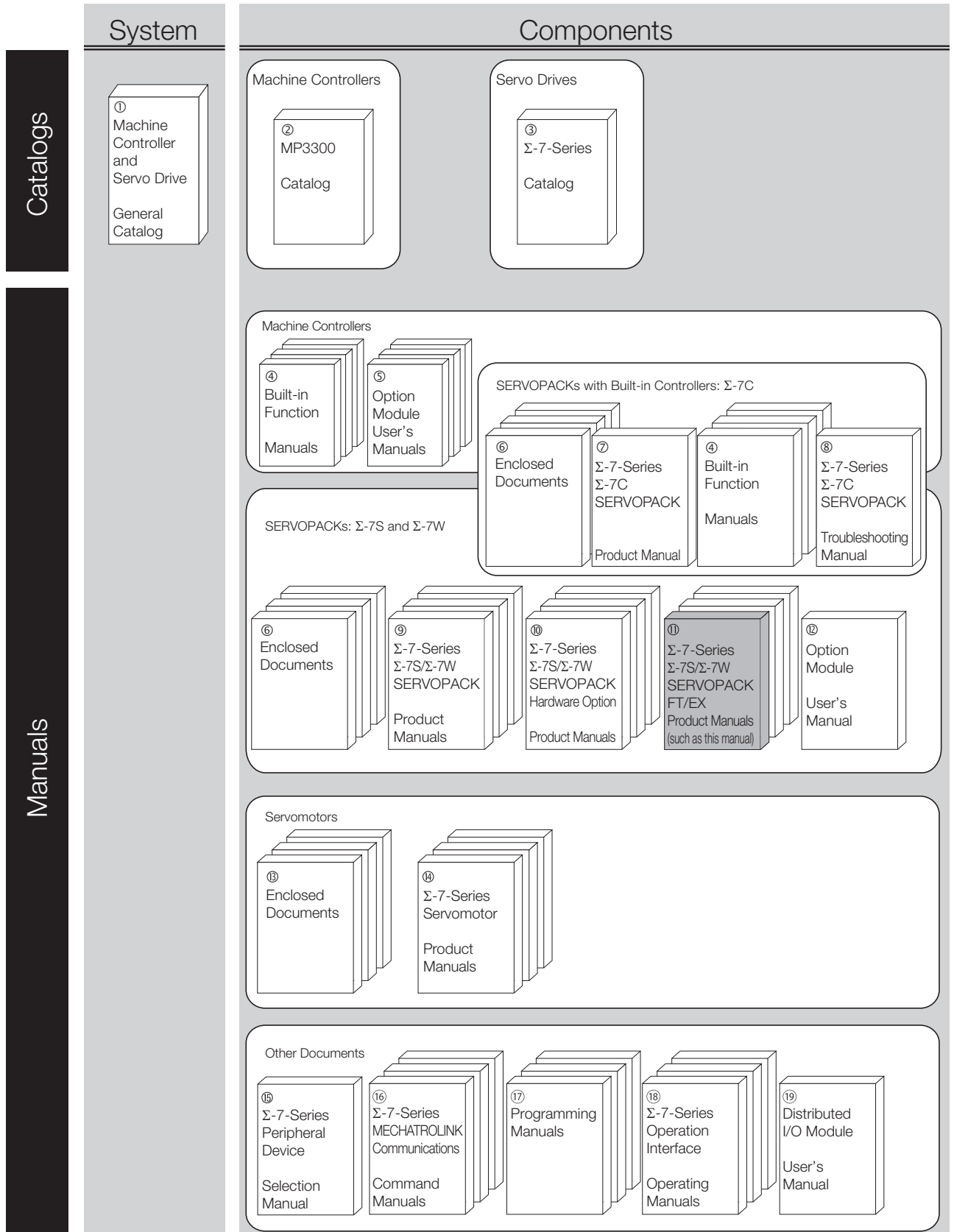

| Classification | Document Name | Document No. | Description |
|---|--|-----------------|---|
| ① Machine Controller and Servo Drive General Catalog | Machine Controller and AC Servo Drive Solutions Catalog | KAEP S800001 22 | Describes the features and application examples for combinations of MP3000-Series Machine Controllers and Σ -7-Series AC Servo Drives. |
| ② MP3300 Catalog | Machine Controller MP3300 | KAEP C880725 03 | Provides detailed information on MP3300 Machine Controllers, including features and specifications. |
| ③ Σ -7-Series Catalog | AC Servo Drives Σ -7 Series | KAEP S800001 23 | Provides detailed information on Σ -7-Series AC Servo Drives, including features and specifications. |
| ④ Built-in Function Manuals | Σ -7-Series AC Servo Drive Σ -7C SERVOPACK Motion Control User's Manual | SIEP S800002 03 | Provides detailed information on the specifications, system configuration, and application methods of the Motion Control Function Modules (SVD, SVC4, and SVR4) for Σ -7-Series Σ -7C SERVOPACKs. |
| | Machine Controller MP3000 Series Communications User's Manual | SIEP C880725 12 | Provides detailed information on the specifications, system configuration, and communications connection methods for the Ethernet communications that are used with MP3000-Series Machine Controllers and Σ -7-Series Σ -7C SERVOPACKs. |
| ⑤ Option Module User's Manuals | Machine Controller MP2000 Series Communication Module User's Manual | SIEP C880700 04 | Provide detailed information on the specifications and communications methods for the Communications Modules that can be mounted to MP3000-Series Machine Controllers and Σ -7-Series Σ -7C SERVOPACKs. |
| | Machine Controller MP2000 Series 262IF-01 FL-net Communication Module User's Manual | SIEP C880700 36 | |
| | Machine Controller MP2000 Series 263IF-01 EtherNet/IP Communication Module User's Manual | SIEP C880700 39 | |
| | Machine Controller MP2000 Series I/O Module User's Manual | SIEP C880700 34 | Provide detailed information on the specifications and communications methods for the I/O Modules that can be mounted to MP3000-Series Machine Controllers and Σ -7-Series Σ -7C SERVOPACKs. |
| | Machine Controller MP2000 Series Analog Input/Analog Output Module AI-01/AO-01 User's Manual | SIEP C880700 26 | |
| | Machine Controller MP2000 Series Counter Module CNTR-01 User's Manual | SIEP C880700 27 | |

Continued on next page.

Continued from previous page.

| Classification | Document Name | Document No. | Description |
|--|---|-----------------|--|
| ⑥ Enclosed Documents | Σ -7-Series AC Servo Drive Σ -7S, Σ -7W, and Σ -7C SER- VOPACK Safety Precautions | TOMP C710828 00 | Provides detailed information for the safe usage of Σ -7-Series SERVOPACKs. |
| | Σ -V-Series/ Σ -V-Series for Large-Capacity Models/ Σ -7-Series Safety Precautions Option Module | TOBP C720829 00 | Provides detailed information for the safe usage of Option Modules. |
| | Σ -V-Series/ Σ -V-Series for Large-Capacity Models/ Σ -7-Series Installation Guide Command Option Module | TOBP C720829 01 | Provides detailed procedures for installing the Command Option Module in a SERVOPACK. |
| | Σ -V-Series/ Σ -V-Series for Large-Capacity Models/ Σ -7-Series Installation Guide Fully-closed Module | TOBP C720829 03 | Provides detailed procedures for installing the Fully-closed Module in a SERVOPACK. |
| | Σ -V-Series/ Σ -V-Series for Large-Capacity Models/ Σ -7-Series Installation Guide Safety Module | TOBP C720829 06 | Provides detailed procedures for installing the Safety Module in a SERVOPACK. |
| | Σ -V-Series/ Σ -V-Series for Large-Capacity Models/ Σ -7-Series Installation Guide INDEXER Module | TOBP C720829 02 | Provides detailed procedures for installing the INDEXER Module in a SERVOPACK. |
| | Σ -V-Series/ Σ -V-Series for Large-Capacity Models/ Σ -7-Series Installation Guide DeviceNet Module | TOBP C720829 07 | Provides detailed procedures for installing the DeviceNet Module in a SERVOPACK. |
| ⑦ Σ -7-Series Σ -7C SERVOPACK Product Manual | Σ -7-Series AC Servo Drive Σ -7C SERVOPACK Product Manual | SIEP S800002 04 | Provides detailed information on selecting Σ -7-Series Σ -7C SERVOPACKs; installing, connecting, setting, testing in trial operation, and tuning Servo Drives; writing, monitoring, and maintaining programs; and other information. |
| ⑧ Σ -7-Series Σ -7C SERVOPACK Troubleshooting Manual | Σ -7-Series AC Servo Drive Σ -7C SERVOPACK Troubleshooting Manual | SIEP S800002 07 | Provides detailed troubleshooting information for Σ -7-Series Σ -7C SERVOPACKs. |

Continued on next page.

Continued from previous page.

| Classification | Document Name | Document No. | Description |
|--|---|-----------------|--|
| ⑨ Σ-7-Series Σ-7S/Σ-7W SERVOPACK Product Manuals | Σ-7-Series AC Servo Drive Σ-7S SERVOPACK with MECHATROLINK-4 Communications References Product Manual | SIEP S800002 31 | Provide detailed information on selecting Σ-7-Series Σ-7S and Σ-7W SERVOPACKs; installing, connecting, setting, testing in trial operation, tuning, monitoring, and maintaining Servo Drives; and other information. |
| | Σ-7-Series AC Servo Drive Σ-7S SERVOPACK with MECHATROLINK-III Communications References Product Manual | SIEP S800001 28 | |
| | Σ-7-Series AC Servo Drive Σ-7S SERVOPACK with MECHATROLINK-II Communications References Product Manual | SIEP S800001 27 | |
| | Σ-7-Series AC Servo Drive Σ-7S SERVOPACK with Analog Voltage/Pulse Train References Product Manual | SIEP S800001 26 | |
| | Σ-7-Series AC Servo Drive Σ-7S SERVOPACK Command Option Attachable Type with INDEXER Module Product Manual | SIEP S800001 64 | |
| | Σ-7-Series AC Servo Drive Σ-7S SERVOPACK Command Option Attachable Type with DeviceNet Module Product Manual | SIEP S800001 70 | |
| | Σ-7-Series AC Servo Drive Σ-7W SERVOPACK with MECHATROLINK-III Communications References Product Manual | SIEP S800001 29 | |
| ⑩ Σ-7-Series Σ-7S/Σ-7W SERVOPACK with Hardware Option Specifications Product Manuals | Σ-7-Series AC Servo Drive Σ-7S/Σ-7W SERVOPACK with Hardware Option Specifica- tions Dynamic Brake Product Manual | SIEP S800001 73 | Provide detailed information on Hardware Options for Σ-7-Series SERVOPACKs. |
| | Σ-7-Series AC Servo Drive Σ-7W/Σ-7C SERVOPACK with Hardware Option Specifica- tions HWBB Function Product Manual | SIEP S800001 72 | |

Continued on next page.

Continued from previous page.

| Classification | Document Name | Document No. | Description |
|--|--|----------------------------------|---|
| ⑩ Σ-7-Series Σ-7S/Σ-7W SERVOPACK FT/EX Product Manuals | Σ-7-Series AC Servo Drive Σ-7S SERVOPACK with FT/EX Specification for Index- ing Application Product Manual | SIEP S800001 84 | Provide detailed information on the FT/EX Option for Σ-7-Series SERVOPACKs. |
| | Σ-7-Series AC Servo Drive Σ-7S SERVOPACK with FT/EX Specification for Track- ing Application Product Manual | This manual (SIEP S800001 89) | |
| | Σ-7-Series AC Servo Drive Σ-7S SERVOPACK with FT/EX Specification for Application with Special Motor, SGM7D Motor Product Manual | SIEP S800001 91 | |
| | Σ-7-Series AC Servo Drive Σ-7S SERVOPACK with FT/EX Specification for Press and Injection Molding Application Product Manual | SIEP S800001 94 | |
| | Σ-7-Series AC Servo Drive Σ-7S SERVOPACK with FT/EX Specification for Transfer and Alignment Application Product Manual | SIEP S800001 95 | |
| | Σ-7-Series AC Servo Drive Σ-7S SERVOPACK with FT/EX Specification for Torque/Force Assistance for Conveyance Application Product Manual | SIEP S800002 09 | |
| | Σ-7-Series AC Servo Drive Σ-7S SERVOPACK with FT/EX Specification for Cutting Application Feed Shaft Motor Product Manual | SIEP S800002 10 | |
| | Σ-7-Series AC Servo Drive Σ-7S SERVOPACK with FT/EX Specification for Three-Point Latching for Conveyance Application Product Manual | SIEP S800002 17 | |
| | Σ-7-Series AC Servo Drive Σ-7S SERVOPACK with FT/EX Specification for Semi-/Fully-Closed Loop Control Online Switching for Conveyance Application Product Manual | SIEP S800002 27 | |
| | Σ-7-Series AC Servo Drive Σ-7W SERVOPACK with FT/EX Specification for Gantry Applications Product Manual | SIEP S800002 29 | |

Continued on next page.

Continued from previous page.

| Classification | Document Name | Document No. | Description |
|--|---|-----------------|--|
| ⑩ Option Module User's Manual | AC Servo Drives Σ -V Series/ Σ -V Series for Large-Capacity Models/ Σ -7 Series User's Manual Safety Module | SIEP C720829 06 | Provides detailed information required for the design and mainte- nance of a Safety Module. |
| ⑪ Enclosed Documents | AC Servo Drive Rotary Servomotor Safety Precautions | TOBP C230260 00 | Provides detailed information for the safe usage of Rotary Servomo- tors and Direct Drive Servomotors. |
| | AC Servomotor Linear Σ Series Safety Precautions | TOBP C230800 00 | Provides detailed information for the safe usage of Linear Servomo- tors. |
| ⑫ Σ -7-Series Servomotor Product Manuals | Σ -7-Series AC Servo Drive Rotary Servomotor Product Manual | SIEP S800001 36 | Provide detailed information on selecting, installing, and connecting the Σ -7-Series Servomotors. |
| | Σ -7-Series AC Servo Drive Linear Servomotor Product Manual | SIEP S800001 37 | |
| | Σ -7-Series AC Servo Drive Direct Drive Servomotor Product Manual | SIEP S800001 38 | |
| ⑬ Σ -7-Series Peripheral Device Selection Manual | Σ -7-Series AC Servo Drive Peripheral Device Selection Manual | SIEP S800001 32 | Provides the following information in detail for Σ -7-Series Servo Sys- tems. • Cables: Models, dimensions, wir- ing materials, connector models, and connection specifications • Peripheral devices: Models, specifications, diagrams, and selection (calculation) methods |
| ⑭ Σ -7-Series MECHATROLINK Communications Command Manuals | Σ -7-Series AC Servo Drive MECHATROLINK-II Communications Command Manual | SIEP S800001 30 | Provides detailed information on the MECHATROLINK-II communi- cations commands that are used for a Σ -7-Series Servo System. |
| | Σ -7-Series AC Servo Drive MECHATROLINK-III Communications Standard Servo Profile Command Manual | SIEP S800001 31 | Provides detailed information on the MECHATROLINK-III communi- cations standard servo profile com- mands that are used for a Σ -7- Series Servo System. |
| | Σ -7-Series AC Servo Drive MECHATROLINK-4 Communications Standard Servo Profile Command Manual | SIEP S800002 32 | Provides detailed information on the MECHATROLINK-4 communi- cations standard servo profile com- mands that are used for a Σ -7-Series Servo System. |
| ⑮ Programming Manuals | Machine Controller MP3000 Series Ladder Programming Manual | SIEP C880725 13 | Provides detailed information on the ladder programming specifica- tions and instructions for MP3000- Series Machine Controllers and Σ -7-Series Σ -7C SERVOPACKs. |
| | Machine Controller MP3000 Series Motion Programming Manual | SIEP C880725 14 | Provides detailed information on the motion programming and sequence programming specifica- tions and instructions for MP3000- Series Machine Controllers and Σ -7-Series Σ -7C SERVOPACKs. |

Continued on next page.

Continued from previous page.

| Classification | Document Name | Document No. | Description |
|--|---|-----------------|--|
| [®] Σ -7-Series Operation Interface Operating Manuals | Machine Controller MP2000/MP3000 Series Engineering Tool MPE720 Version 7 User's Manual | SIEP C880761 03 | Describes in detail how to operate MPE720 version 7. |
| | Σ -7-Series AC Servo Drive Digital Operator Operating Manual | SIEP S800001 33 | Describes the operating procedures for a Digital Operator for a Σ -7-Series Servo System. |
| | AC Servo Drive Engineering Tool SigmaWin+ Operation Manual | SIET S800001 34 | Provides detailed operating procedures for the SigmaWin+ Engineering Tool for a Σ -7-Series Servo System. |
| [®] Distributed I/O Module User's Manual | MECHATROLINK-III Compatible I/O Module User's Manual | SIEP C880781 04 | Describes the functions, specifications, operating methods, and MECHATROLINK-III communications for the Remote I/O Modules for MP2000/MP3000-Series Machine Controllers. |
| | MECHATROLINK-4 Compatible I/O Module User's Manual | SIEP C880782 01 | Describes the functions, specifications, operating methods, and MECHATROLINK-4 communications for the Remote I/O Modules for MP3000-Series Machine Controllers. |

Using This Manual

◆ Technical Terms Used in This Manual

The following terms are used in this manual.

| Term | Meaning |
|--------------------|--|
| Servomotor | A Σ -7-Series Rotary Servomotor, Direct Drive Servomotor, or Linear Servomotor. |
| Rotary Servomotor | A generic term used for a Σ -7-Series Rotary Servomotor (SGM7M, SGM7J, SGM7A, SGM7P, SGM7G, or SGM7V) or a Direct Drive Servomotor (SGM7E, SGM7F, SGM7C, or SGM7S). The descriptions will specify when Direct Drive Servomotors are excluded. |
| Linear Servomotor | A Σ -7-Series Linear Servomotor (SGLG, SGLF, SGLT, or SGLC). |
| SERVOPACK | A Σ -7-Series Σ -7S Servo Amplifier with Analog Voltage/Pulse Train References or MECHATROLINK-III Communications References |
| Servo Drive | The combination of a Servomotor and SERVOPACK. |
| Servo System | A servo control system that includes the combination of a Servo Drive with a host controller and peripheral devices. |
| servo ON | Supplying power to the motor. |
| servo OFF | Not supplying power to the motor. |
| base block (BB) | Shutting OFF the power supply to the motor by shutting OFF the base current to the power transistor in the SERVOPACK. |
| servo lock | A state in which the motor is stopped and is in a position loop with a position reference of 0. |
| Main Circuit Cable | One of the cables that connect to the main circuit terminals, including the Main Circuit Power Supply Cable, Control Power Supply Cable, and Servomotor Main Circuit Cable. |
| SigmaWin+ | The Engineering Tool for setting up and tuning Servo Drives or a computer in which the Engineering Tool is installed. |

◆ Differences in Terms for Rotary Servomotors and Linear Servomotors

There are differences in the terms that are used for Rotary Servomotors and Linear Servomotors. This manual primarily describes Rotary Servomotors. If you are using a Linear Servomotor, you need to interpret the terms as given in the following table.

| Rotary Servomotors | Linear Servomotors |
|---------------------------------------|---------------------------------------|
| torque | force |
| moment of inertia | mass |
| rotation | movement |
| forward rotation and reverse rotation | forward movement and reverse movement |
| CW and CCW pulse trains | forward and reverse pulse trains |
| rotary encoder | linear encoder |
| absolute rotary encoder | absolute linear encoder |
| incremental rotary encoder | incremental linear encoder |
| unit: min^{-1} | unit: mm/s |
| unit: $\text{N}\cdot\text{m}$ | unit: N |

◆ Notation Used in this Manual

■ Notation for Reverse Signals

The names of reverse signals (i.e., ones that are valid when low) are written with a forward slash (/) before the signal abbreviation.

Notation Example

\overline{BK} is written as /BK.

■ Notation for Parameters

The notation depends on whether the parameter requires a numeric setting (parameter for numeric setting) or requires the selection of a function (parameter for selecting functions).

• Parameters for Numeric Settings

The control methods for which the parameters apply are given.
Speed : Speed control Position : Position control Torque : Torque control

| Pn100 | Speed Loop Gain | | | | | Speed | Position |
|-------|-----------------|--------------|-----------------|--------------|----------------|--------------------|-----------------------|
| | Setting Range | Setting Unit | Default Setting | When Enabled | Classification | | |
| | 10 to 20,000 | 0.1 Hz | 400 | Immediately | Tuning | | |

Parameter number: Pn100

This is the setting range for the parameter.

This is the minimum unit (setting increment) that you can set for the parameter.

This is the parameter setting before shipment.

This is when any change made to the parameter will become effective.

This is the parameter classification.

• Parameters for Selecting Functions

| Parameter | Meaning | When Enabled | Classification |
|-----------|--------------------------|---------------|----------------|
| Pn002 | n.□□□□ (default setting) | After restart | Setup |
| | n.□1□□ | | |
| | n.□2□□ | | |

Parameter number: Pn002

The notation "n.□□□□" indicates a parameter for selecting functions. Each □ indicates the setting for one digit. The notation shown here means that the third digit from the right is set to 2.

This column explains the selections for the function.

Notation Example

Notation Examples for Pn002

| n . 0 0 0 0 | Digit Notation | | Numeric Value Notation | |
|-------------|----------------|---|------------------------|--|
| | Notation | Meaning | Notation | Meaning |
| → | Pn002 = n.□□□X | Indicates the first digit from the right in Pn002. | Pn002 = n.□□□1 | Indicates that the first digit from the right in Pn002 is set to 1. |
| → | Pn002 = n.□□X□ | Indicates the second digit from the right in Pn002. | Pn002 = n.□□1□ | Indicates that the second digit from the right in Pn002 is set to 1. |
| → | Pn002 = n.□X□□ | Indicates the third digit from the right in Pn002. | Pn002 = n.□1□□ | Indicates that the third digit from the right in Pn002 is set to 1. |
| → | Pn002 = n.X□□□ | Indicates the fourth digit from the right in Pn002. | Pn002 = n.1□□□ | Indicates that the fourth digit from the right in Pn002 is set to 1. |

◆ Engineering Tools Used in This Manual

This manual uses the interfaces of the SigmaWin+ for descriptions.

◆ Trademarks

- MECHATROLINK is a trademark of the MECHATROLINK Members Association.
- QR code is a trademark of Denso Wave Inc.
- Other product names and company names are the trademarks or registered trademarks of the respective company. “TM” and the ® mark do not appear with product or company names in this manual.

◆ Visual Aids

The following aids are used to indicate certain types of information for easier reference.



Indicates precautions or restrictions that must be observed.
Also indicates alarm displays and other precautions that will not result in machine damage.



Indicates definitions of difficult terms or terms that have not been previously explained in this manual.

Example Indicates operating or setting examples.

Information Indicates supplemental information to deepen understanding or useful information.

Safety Precautions

◆ Safety Information

To prevent personal injury and equipment damage in advance, the following signal words are used to indicate safety precautions in this document. The signal words are used to classify the hazards and the degree of damage or injury that may occur if a product is used incorrectly. Information marked as shown below is important for safety. Always read this information and heed the precautions that are provided.



DANGER

- Indicates precautions that, if not heeded, are likely to result in loss of life, serious injury, or fire.



WARNING

- Indicates precautions that, if not heeded, could result in loss of life, serious injury, or fire.



CAUTION

- Indicates precautions that, if not heeded, could result in relatively serious or minor injury, or in fire.

NOTICE

- Indicates precautions that, if not heeded, could result in property damage.

◆ Safety Precautions That Must Always Be Observed

■ General Precautions



DANGER

- Read and understand this manual to ensure the safe usage of the product.
- Keep this manual in a safe, convenient place so that it can be referred to whenever necessary. Make sure that it is delivered to the final user of the product.
- Do not remove covers, cables, connectors, or optional devices while power is being supplied to the SERVOPACK.
There is a risk of electric shock, operational failure of the product, or burning.



WARNING

- Use a power supply with specifications (number of phases, voltage, frequency, and AC/DC type) that are appropriate for the product.
There is a risk of burning, electric shock, or fire.
- Connect the ground terminals on the SERVOPACK and Servomotor to ground poles according to local electrical codes (100 Ω or less for a SERVOPACK with a 100-VAC or 200-VAC power supply, and 10 Ω or less for a SERVOPACK with a 400-VAC power supply).
There is a risk of electric shock or fire.
- Do not attempt to disassemble, repair, or modify the product.
There is a risk of fire or failure.
The warranty is void for the product if you disassemble, repair, or modify it.



CAUTION

- The SERVOPACK heat sinks, regenerative resistors, External Dynamic Brake Resistors, Servomotors, and other components can be very hot while power is ON or soon after the power is turned OFF. Implement safety measures, such as installing covers, so that hands and parts such as cables do not come into contact with hot components.
There is a risk of burn injury.
- For a 24-VDC power supply, use a power supply device with double insulation or reinforced insulation.
There is a risk of electric shock.
- Do not damage, pull on, apply excessive force to, place heavy objects on, or pinch cables.
There is a risk of failure, damage, or electric shock.
- The person who designs the system that uses the hard wire base block safety function must have a complete knowledge of the related safety standards and a complete understanding of the instructions in this document.
There is a risk of injury, product damage, or machine damage.
- Do not use the product in an environment that is subject to water, corrosive gases, or flammable gases, or near flammable materials.
There is a risk of electric shock or fire.

NOTICE

- Do not attempt to use a SERVOPACK or Servomotor that is damaged or that has missing parts.
- Install external emergency stop circuits that shut OFF the power supply and stops operation immediately when an error occurs.
- In locations with poor power supply conditions, install the necessary protective devices (such as AC reactors) to ensure that the input power is supplied within the specified voltage range. There is a risk of damage to the SERVOPACK.
- Use a Noise Filter to minimize the effects of electromagnetic interference. Electronic devices used near the SERVOPACK may be affected by electromagnetic interference.
- Always use a Servomotor and SERVOPACK in one of the specified combinations.
- Do not touch a SERVOPACK or Servomotor with wet hands. There is a risk of product failure.

■ Storage Precautions



CAUTION

- Do not place an excessive load on the product during storage. (Follow all instructions on the packages.) There is a risk of injury or damage.

NOTICE

- Do not install or store the product in any of the following locations.
 - Locations that are subject to direct sunlight
 - Locations that are subject to ambient temperatures that exceed product specifications
 - Locations that are subject to relative humidities that exceed product specifications
 - Locations that are subject to condensation as the result of extreme changes in temperature
 - Locations that are subject to corrosive or flammable gases
 - Locations that are near flammable materials
 - Locations that are subject to dust, salts, or iron powder
 - Locations that are subject to water, oil, or chemicals
 - Locations that are subject to vibration or shock that exceeds product specifications
 - Locations that are subject to radiationIf you store or install the product in any of the above locations, the product may fail or be damaged.

■ Transportation Precautions



CAUTION

- Transport the product in a way that is suitable to the mass of the product.
- Do not use the eyebolts on a SERVOPACK or Servomotor to move the machine. There is a risk of damage or injury.
- When you handle a SERVOPACK or Servomotor, be careful of sharp parts, such as the corners. There is a risk of injury.
- Do not place an excessive load on the product during transportation. (Follow all instructions on the packages.) There is a risk of injury or damage.

NOTICE

- Do not hold onto the front cover or connectors when you move a SERVOPACK.
There is a risk of the SERVOPACK falling.
- A SERVOPACK or Servomotor is a precision device. Do not drop it or subject it to strong shock.
There is a risk of failure or damage.
- Do not subject connectors to shock.
There is a risk of faulty connections or damage.
- If disinfectants or insecticides must be used to treat packing materials such as wooden frames, plywood, or pallets, the packing materials must be treated before the product is packaged, and methods other than fumigation must be used.
Example: Heat treatment, where materials are kiln-dried to a core temperature of 56°C for 30 minutes or more.
If the electronic products, which include stand-alone products and products installed in machines, are packed with fumigated wooden materials, the electrical components may be greatly damaged by the gases or fumes resulting from the fumigation process. In particular, disinfectants containing halogen, which includes chlorine, fluorine, bromine, or iodine can contribute to the erosion of the capacitors.
- Do not overtighten the eyebolts on a SERVOPACK or Servomotor.
If you use a tool to overtighten the eyebolts, the tapped holes may be damaged.

■ Installation Precautions



CAUTION

- Install the Servomotor or SERVOPACK in a way that will support the mass given in technical documents.
- Install SERVOPACKs, Servomotors, regenerative resistors, and External Dynamic Brake Resistors on nonflammable materials.
Installation directly onto or near flammable materials may result in fire.
- Provide the specified clearances between the SERVOPACK and the control panel as well as with other devices.
There is a risk of fire or failure.
- Install the SERVOPACK in the specified orientation.
There is a risk of fire or failure.
- Do not step on or place a heavy object on the product.
There is a risk of failure, damage, or injury.
- Do not allow any foreign matter to enter the SERVOPACK or Servomotor.
There is a risk of failure or fire.

NOTICE

- **Do not install or store the product in any of the following locations.**
 - Locations that are subject to direct sunlight
 - Locations that are subject to ambient temperatures that exceed product specifications
 - Locations that are subject to relative humidities that exceed product specifications
 - Locations that are subject to condensation as the result of extreme changes in temperature
 - Locations that are subject to corrosive or flammable gases
 - Locations that are near flammable materials
 - Locations that are subject to dust, salts, or iron powder
 - Locations that are subject to water, oil, or chemicals
 - Locations that are subject to vibration or shock that exceeds product specifications
 - Locations that are subject to radiationIf you store or install the product in any of the above locations, the product may fail or be damaged.
- **Use the product in an environment that is appropriate for the product specifications.**

If you use the product in an environment that exceeds product specifications, the product may fail or be damaged.
- **A SERVOPACK or Servomotor is a precision device. Do not drop it or subject it to strong shock.**

There is a risk of failure or damage.
- **Always install a SERVOPACK in a control panel.**
- **Do not allow any foreign matter to enter a SERVOPACK or a Servomotor with a Cooling Fan and do not cover the outlet from the Servomotor's cooling fan.**

There is a risk of failure.

■ Wiring Precautions



DANGER

- **Do not change any wiring while power is being supplied.**

There is a risk of electric shock or injury.



WARNING

- **Wiring and inspections must be performed only by qualified engineers.**

There is a risk of electric shock or product failure.
- **Check all wiring and power supplies carefully.**

Incorrect wiring or incorrect voltage application to the output circuits may cause short-circuit failures. If a short-circuit failure occurs as a result of any of these causes, the holding brake will not work. This could damage the machine or cause an accident that may result in death or injury.
- **Connect the AC and DC power supplies to the specified SERVOPACK terminals.**
 - Connect an AC power supply to the L1, L2, and L3 terminals and the L1C and L2C terminals on the SERVOPACK.
 - Connect a DC power supply to the B1/⊕ and ⊖2 terminals and the L1C and L2C terminals on the SERVOPACK.

There is a risk of failure or fire.
- **If you use a SERVOPACK that supports a Dynamic Brake Option, connect an External Dynamic Brake Resistor that is suitable for the machine and equipment specifications to the specified terminals.**

There is a risk of unexpected operation, machine damage, burning, or injury when an emergency stop is performed.



CAUTION

- Wait for at least six minutes after turning OFF the power supply (with a SERVOPACK for a 100-VAC power supply input, wait for at least nine minutes) and then make sure that the CHARGE indicator is not lit before starting wiring or inspection work. Do not touch the power supply terminals while the CHARGE lamp is lit because high voltage may still remain in the SERVOPACK after turning OFF the power supply.
There is a risk of electric shock.
- Observe the precautions and instructions for wiring and trial operation precisely as described in this document.
Failures caused by incorrect wiring or incorrect voltage application in the brake circuit may cause the SERVOPACK to fail, damage the equipment, or cause an accident resulting in death or injury.
- Check the wiring to be sure it has been performed correctly.
Connectors and pin layouts are sometimes different for different models. Always confirm the pin layouts in technical documents for your model before operation.
There is a risk of failure or malfunction.
- Connect wires to power supply terminals and motor connection terminals securely with the specified methods and tightening torque.
Insufficient tightening may cause wires and terminal blocks to generate heat due to faulty contact, possibly resulting in fire.
- Use shielded twisted-pair cables or screened unshielded multi-twisted-pair cables for I/O Signal Cables and Encoder Cables.
- The maximum wiring length is 3 m for I/O Signal Cables, and 50 m for Encoder Cables or Servomotor Main Circuit Cables.
- Observe the following precautions when wiring the SERVOPACK's main circuit terminals.
 - Turn ON the power supply to the SERVOPACK only after all wiring, including the main circuit terminals, has been completed.
 - If a connector is used for the main circuit terminals, remove the main circuit connector from the SERVOPACK before you wire it.
 - Insert only one wire per insertion hole in the main circuit terminals.
 - When you insert a wire, make sure that the conductor wire (e.g., whiskers) does not come into contact with adjacent wires and cause a short-circuit.
- Install molded-case circuit breakers and other safety measures to provide protection against short circuits in external wiring.
There is a risk of fire or failure.

NOTICE

- Whenever possible, use the Cables specified by Yaskawa.
If you use any other cables, confirm the rated current and application environment of your model and use the wiring materials specified by Yaskawa or equivalent materials.
- Securely tighten cable connector screws and lock mechanisms.
Insufficient tightening may result in cable connectors falling off during operation.
- Do not bundle power lines (e.g., the Main Circuit Cable) and low-current lines (e.g., the I/O Signal Cables or Encoder Cables) together or run them through the same duct. If you do not place power lines and low-current lines in separate ducts, separate them by at least 30 cm.
If the cables are too close to each other, malfunctions may occur due to noise affecting the low-current lines.
- Install a battery at either the host controller or on the Encoder Cable.
If you install batteries both at the host controller and on the Encoder Cable at the same time, you will create a loop circuit between the batteries, resulting in a risk of damage or burning.
- When connecting a battery, connect the polarity correctly.
There is a risk of battery rupture or encoder failure.

■ Operation Precautions



WARNING

- Before starting operation with a machine connected, change the settings of the switches and parameters to match the machine.
Unexpected machine operation, failure, or personal injury may occur if operation is started before appropriate settings are made.
- Do not radically change the settings of the parameters.
There is a risk of unstable operation, machine damage, or injury.
- Install limit switches or stoppers at the ends of the moving parts of the machine to prevent unexpected accidents.
There is a risk of machine damage or injury.
- For trial operation, securely mount the Servomotor and disconnect it from the machine.
There is a risk of injury.
- Forcing the motor to stop for overtravel is disabled when the Jog, Origin Search, or Easy FFT utility function is executed. Take necessary precautions.
There is a risk of machine damage or injury.
- When an alarm occurs, the Servomotor will coast to a stop or stop with the dynamic brake according to the SERVOPACK Option specifications and settings. The coasting distance will change with the moment of inertia of the load and the resistance of the External Dynamic Brake Resistor. Check the coasting distance during trial operation and implement suitable safety measures on the machine.
- Do not enter the machine's range of motion during operation.
There is a risk of injury.
- Do not touch the moving parts of the Servomotor or machine during operation.
There is a risk of injury.



CAUTION

- Design the system to ensure safety even when problems, such as broken signal lines, occur. For example, the P-OT and N-OT signals are set in the default settings to operate on the safe side if a signal line breaks. Do not change the polarity of this type of signal.
- When overtravel occurs, the power supply to the motor is turned OFF and the brake is released. If you use the Servomotor to drive a vertical load, set the Servomotor to enter a zero-clamped state after the Servomotor stops. Also, install safety devices (such as an external brake or counterweight) to prevent the moving parts of the machine from falling.
- Always turn OFF the servo before you turn OFF the power supply. If you turn OFF the main circuit power supply or control power supply during operation before you turn OFF the servo, the Servomotor will stop as follows:
 - If you turn OFF the main circuit power supply during operation without turning OFF the servo, the Servomotor will stop abruptly with the dynamic brake.
 - If you turn OFF the control power supply without turning OFF the servo, the stopping method that is used by the Servomotor depends on the model of the SERVOPACK. For details, refer to the manual for the SERVOPACK.
 - If you use a SERVOPACK with the Dynamic Brake Hardware Option, the Servomotor stopping methods will be different from the stopping methods used without the Option or with other Hardware Options. For details, refer to the following manual.
 Σ -7-Series Σ -7S/ Σ -7W SERVOPACK with Dynamic Brake Hardware Option Specifications Product Manual (Manual No.: SIEP S800001 73)
- Do not use the dynamic brake for any application other than an emergency stop.
There is a risk of failure due to rapid deterioration of elements in the SERVOPACK and the risk of unexpected operation, machine damage, burning, or injury.

NOTICE

- When you adjust the gain during system commissioning, use a measuring instrument to monitor the torque waveform and speed waveform and confirm that there is no vibration.
If a high gain causes vibration, the Servomotor will be damaged quickly.
- Do not frequently turn the power supply ON and OFF. After you have started actual operation, allow at least one hour between turning the power supply ON and OFF (as a guideline).
Do not use the product in applications that require the power supply to be turned ON and OFF frequently.
The elements in the SERVOPACK will deteriorate quickly.
- An alarm or warning may occur if communications are performed with the host controller while the SigmaWin+ or Digital Operator is operating.
If an alarm or warning occurs, it may interrupt the current process and stop the system.
- After you complete trial operation of the machine and facilities, use the SigmaWin+ to back up the settings of the SERVOPACK parameters. You can use them to reset the parameters after SERVOPACK replacement.
If you do not copy backed up parameter settings, normal operation may not be possible after a faulty SERVOPACK is replaced, possibly resulting in machine or equipment damage.

■ Maintenance and Inspection Precautions

DANGER

- Do not change any wiring while power is being supplied.
There is a risk of electric shock or injury.

WARNING

- Wiring and inspections must be performed only by qualified engineers.
There is a risk of electric shock or product failure.

CAUTION

- Wait for at least six minutes after turning OFF the power supply (with a SERVOPACK for a 100-VAC power supply input, wait for at least nine minutes) and then make sure that the CHARGE indicator is not lit before starting wiring or inspection work. Do not touch the power supply terminals while the CHARGE lamp is lit because high voltage may still remain in the SERVOPACK after turning OFF the power supply.
There is a risk of electric shock.
- Before you replace a SERVOPACK, back up the settings of the SERVOPACK parameters. Copy the backed up parameter settings to the new SERVOPACK and confirm that they were copied correctly.
If you do not copy backed up parameter settings or if the copy operation is not completed normally, normal operation may not be possible, possibly resulting in machine or equipment damage.

NOTICE

- Discharge all static electricity from your body before you operate any of the buttons or switches inside the front cover of the SERVOPACK.
There is a risk of equipment damage.

■ Troubleshooting Precautions



DANGER

- If the safety device (molded-case circuit breaker or fuse) installed in the power supply line operates, remove the cause before you supply power to the SERVOPACK again. If necessary, repair or replace the SERVOPACK, check the wiring, and remove the factor that caused the safety device to operate.

There is a risk of fire, electric shock, or injury.



WARNING

- The product may suddenly start to operate when the power supply is recovered after a momentary power interruption. Design the machine to ensure human safety when operation restarts.

There is a risk of injury.



CAUTION

- When an alarm occurs, remove the cause of the alarm and ensure safety. Then reset the alarm or turn the power supply OFF and ON again to restart operation.
There is a risk of injury or machine damage.
- If the Servo ON signal is input to the SERVOPACK and an alarm is reset, the Servomotor may suddenly restart operation. Confirm that the servo is OFF and ensure safety before you reset an alarm.
There is a risk of injury or machine damage.
- Always insert a magnetic contactor in the line between the main circuit power supply and the main circuit power supply terminals on the SERVOPACK so that the power supply can be shut OFF at the main circuit power supply.
If a magnetic contactor is not connected when the SERVOPACK fails, a large current may flow, possibly resulting in fire.
- If an alarm occurs, shut OFF the main circuit power supply.
There is a risk of fire due to a regenerative resistor overheating as the result of regenerative transistor failure.
- Install a ground fault detector against overloads and short-circuiting or install a molded-case circuit breaker combined with a ground fault detector.
There is a risk of SERVOPACK failure or fire if a ground fault occurs.
- The holding brake on a Servomotor will not ensure safety if there is the possibility that an external force (including gravity) may move the current position and create a hazardous situation when power is interrupted or an error occurs. If an external force may cause movement, install an external braking mechanism that ensures safety.

■ Disposal Precautions

- Correctly discard the product as stipulated by regional, local, and municipal laws and regulations. Be sure to include these contents in all labelling and warning notifications on the final product as necessary.



■ General Precautions

- Figures provided in this document are typical examples or conceptual representations. There may be differences between them and actual wiring, circuits, and products.
- The products shown in illustrations in this document are sometimes shown without covers or protective guards. Always replace all covers and protective guards before you use the product.
- If you need a new copy of this document because it has been lost or damaged, contact your nearest Yaskawa representative or one of the offices listed on the back of this document.
- This document is subject to change without notice for product improvements, specifications changes, and improvements to the manual itself.
We will update the document number of the document and issue revisions when changes are made.
- Any and all quality guarantees provided by Yaskawa are null and void if the customer modifies the product in any way. Yaskawa disavows any responsibility for damages or losses that are caused by modified products.

Warranty

◆ Details of Warranty

■ Warranty Period

The warranty period for a product that was purchased (hereinafter called the “delivered product”) is one year from the time of delivery to the location specified by the customer or 18 months from the time of shipment from the Yaskawa factory, whichever is sooner.

■ Warranty Scope

Yaskawa shall replace or repair a defective product free of charge if a defect attributable to Yaskawa occurs during the above warranty period.

This warranty does not cover defects caused by the delivered product reaching the end of its service life and replacement of parts that require replacement or that have a limited service life.

This warranty does not cover failures that result from any of the following causes.

- Improper handling, abuse, or use in unsuitable conditions or in environments not described in product catalogs or manuals, or in any separately agreed-upon specifications
- Causes not attributable to the delivered product itself
- Modifications or repairs not performed by Yaskawa
- Use of the delivered product in a manner in which it was not originally intended
- Causes that were not foreseeable with the scientific and technological understanding at the time of shipment from Yaskawa
- Events for which Yaskawa is not responsible, such as natural or human-made disasters

◆ Limitations of Liability

- Yaskawa shall in no event be responsible for any damage or loss of opportunity to the customer that arises due to failure of the delivered product.
- Yaskawa shall not be responsible for any programs (including parameter settings) or the results of program execution of the programs provided by the user or by a third party for use with programmable Yaskawa products.
- The information described in product catalogs or manuals is provided for the purpose of the customer purchasing the appropriate product for the intended application. The use thereof does not guarantee that there are no infringements of intellectual property rights or other proprietary rights of Yaskawa or third parties, nor does it construe a license.
- Yaskawa shall not be responsible for any damage arising from infringements of intellectual property rights or other proprietary rights of third parties as a result of using the information described in catalogs or manuals.

◆ Suitability for Use

- It is the customer's responsibility to confirm conformity with any standards, codes, or regulations that apply if the Yaskawa product is used in combination with any other products.
- The customer must confirm that the Yaskawa product is suitable for the systems, machines, and equipment used by the customer.
- Consult with Yaskawa to determine whether use in the following applications is acceptable. If use in the application is acceptable, use the product with extra allowance in ratings and specifications, and provide safety measures to minimize hazards in the event of failure.
 - Outdoor use, use involving potential chemical contamination or electrical interference, or use in conditions or environments not described in product catalogs or manuals
 - Nuclear energy control systems, combustion systems, railroad systems, aviation systems, vehicle systems, medical equipment, amusement machines, and installations subject to separate industry or government regulations
 - Systems, machines, and equipment that may present a risk to life or property
 - Systems that require a high degree of reliability, such as systems that supply gas, water, or electricity, or systems that operate continuously 24 hours a day
 - Other systems that require a similar high degree of safety
- Never use the product for an application involving serious risk to life or property without first ensuring that the system is designed to secure the required level of safety with risk warnings and redundancy, and that the Yaskawa product is properly rated and installed.
- The circuit examples and other application examples described in product catalogs and manuals are for reference. Check the functionality and safety of the actual devices and equipment to be used before using the product.
- Read and understand all use prohibitions and precautions, and operate the Yaskawa product correctly to prevent accidental harm to third parties.

◆ Specifications Change

The names, specifications, appearance, and accessories of products in product catalogs and manuals may be changed at any time based on improvements and other reasons. The next editions of the revised catalogs or manuals will be published with updated code numbers. Consult with your Yaskawa representative to confirm the actual specifications before purchasing a product.

Compliance with UL Standards, EU Directives, and Other Safety Standards

Certification marks for the standards for which the product has been certified by certification bodies are shown on nameplate. Products that do not have the marks are not certified for the standards.

◆ North American Safety Standards (UL)



| Product | Model | North American Safety Standards (UL File No.) |
|--------------------------|---|---|
| SERVOPACKs | SGD7S | UL 61800-5-1 (E147823) CSA C22.2 No.274 |
| Rotary Servomotors | <ul style="list-style-type: none"> • SGM7M • SGM7A • SGM7J • SGM7P • SGM7G • SGMMV | UL 1004-1 UL 1004-6 (E165827) |
| Direct Drive Servomotors | <ul style="list-style-type: none"> • SGM7E • SGM7F-□□A, -□□B, -□□C, and -□□D (Small-Capacity Servomotors with Cores) • SGMCV • SGMCS-□□B, -□□C, -□□D, and -□□E (Small-Capacity, Coreless Servomotors) | UL 1004-1 UL 1004-6 (E165827) |
| Linear Servomotors | <ul style="list-style-type: none"> • SGLGW* • SGLFW* • SGLFW2 • SGLTW* | UL 1004-1 UL 1004-6 (E165827) |

* Only products with derating specifications are in compliance with the UL Standards. Estimates are available for those products. Contact your Yaskawa representative for details.

◆ EU Directives



| Product | Model | EU Directives | Harmonized Standards |
|--------------------------|---|-------------------------------------|---|
| SERVOPACKs | SGD7S | Machinery Directive 2006/42/EC | EN ISO13849-1: 2015 |
| | | EMC Directive 2014/30/EU | EN 55011 group 1, class A EN 61000-6-2 EN 61000-6-4 EN 61800-3 (Category C2, Second environment) |
| | | Low Voltage Directive 2014/35/EU | EN 50178 EN 61800-5-1 |
| | | RoHS Directive 2011/65/EU | EN 50581 |
| Rotary Servomotors | SGMMV | EMC Directive 2004/108/EC | EN 55011 group 1, class A EN 61000-6-2 EN 61800-3 (Category C2, Second environment) |
| | | Low Voltage Directive 2006/95/EC | EN 60034-1 EN 60034-5 |
| | | RoHS Directive 2011/65/EU | EN 50581 |
| | <ul style="list-style-type: none"> • SGM7M • SGM7J • SGM7A • SGM7P • SGM7G | EMC Directive 2014/30/EU | EN 55011 group 1, class A EN 61000-6-2 EN 61000-6-4 EN 61800-3 (Category C2, Second environment) |
| | | Low Voltage Directive 2014/35/EU | EN 60034-1 EN 60034-5 |
| | | RoHS Directive 2011/65/EU | EN 50581 |
| Direct Drive Servomotors | <ul style="list-style-type: none"> • SGM7E • SGM7F • SGMCV • SGMCS-□□B, -□□C, -□□D, and -□□E (Small-Capacity, Coreless Servomotors)*1 | EMC Directive 2014/30/EU | EN 55011 group 1, class A EN 61000-6-2 EN 61000-6-4 EN 61800-3 (Category C2, Second environment) |
| | | Low Voltage Directive 2014/35/EU | EN 60034-1 EN 60034-5 |
| | | RoHS Directive 2011/65/EU | EN 50581 |
| Linear Servomotors | <ul style="list-style-type: none"> • SGLG*2 • SGLF*2 • SGLF□2 • SGLT*2 | EMC Directive 2014/30/EU | EN 55011 group 1, class A EN 61000-6-2 EN 61000-6-4 EN 61800-3 (Category C2, Second environment) |
| | | Low Voltage Directive 2014/35/EU | EN 60034-1 |
| | | RoHS Directive 2011/65/EU | EN 50581 |

*1. Only models with “-E” at the end of model numbers are in compliance with the standards. Estimates are available for those models. Contact your Yaskawa representative for details.

*2. For Moving Coils, only models with “-E” at the end of model numbers are in compliance with the standards.

Note: 1. We declared the CE Marking based on the harmonized standards in the above table.

2. These products are for industrial use. In home environments, these products may cause electromagnetic interference and additional noise reduction measures may be necessary.

◆ Safety Standards



| Product | Model | Safety Standards | Standards |
|------------|-------|---------------------|--|
| SERVOPACKs | SGD7S | Safety of Machinery | EN ISO13849-1: 2015 IEC 60204-1 |
| | | Functional Safety | IEC 61508 series IEC 62061 IEC 61800-5-2 |
| | | EMC | IEC 61326-3-1 |

■ Safety Parameters

| Item | Standards | Performance Level | |
|--|------------------------|--|--|
| Safety Integrity Level | IEC 61508 | SIL3 | |
| | IEC 62061 | SILCL3 | |
| Mission Time | IEC 61508 | 10 years | 20 years |
| Probability of Dangerous Failure per Hour | IEC 61508 IEC 62061 | PFH = 4.04×10^{-9} [1/h] (4.04% of SIL3) | PFH = 4.05×10^{-9} [1/h] (4.05% of SIL3) |
| Performance Level | EN ISO 13849-1 | PLe (Category 3) | |
| Mean Time to Dangerous Failure of Each Channel | EN ISO 13849-1 | MTTFd: High | |
| Average Diagnostic Coverage | EN ISO 13849-1 | DCavg: Medium | |
| Stop Category | IEC 60204-1 | Stop category 0 | |
| Safety Function | IEC 61800-5-2 | STO | |
| Hardware Fault Tolerance | IEC 61508 | HFT = 1 | |
| Subsystem | IEC 61508 | B | |

Contents

| | |
|--|-------|
| About this Manual | iii |
| Outline of Manual | iii |
| Related Documents | v |
| Using This Manual | xii |
| Safety Precautions | xv |
| Warranty | xxv |
| Compliance with UL Standards, EU Directives, and Other Safety Standards. . . | xxvii |

1

Basic Information on SERVOPACKs

| | | |
|------------|---|-------------|
| 1.1 | Product Introduction | 1-2 |
| 1.2 | Model Designations | 1-3 |
| | 1.2.1 Interpreting SERVOPACK Model Numbers | 1-3 |
| | 1.2.2 Interpreting Servomotor Model Numbers | 1-3 |
| 1.3 | Combinations of SERVOPACKs and Servomotors. | 1-4 |
| 1.4 | Functions | 1-5 |
| | 1.4.1 SERVOPACK Functions | 1-5 |
| | 1.4.2 Functional Restrictions | 1-8 |
| 1.5 | SigmaWin+ | 1-9 |
| 1.6 | Combining the SERVOPACKs with MP-Series Machine Controllers and the MPE720 Engineering Tool. . . | 1-10 |

2

SERVOPACK Ratings and Specifications

| | | |
|------------|--|------------|
| 2.1 | Ratings | 2-2 |
| 2.2 | SERVOPACK Overload Protection Characteristics | 2-5 |
| 2.3 | Specifications. | 2-6 |
| | 2.3.1 SERVOPACKs with Analog Voltage/Pulse Train References | 2-6 |
| | 2.3.2 SERVOPACKs with MECHATROLINK-III Communications References | 2-10 |

3

Less-Deviation Control

| | | |
|------------|--|-------------|
| 3.1 | Introduction | 3-2 |
| 3.2 | Restrictions | 3-3 |
| 3.2.1 | Control Mode Restrictions | 3-3 |
| 3.2.2 | Functional Restrictions | 3-3 |
| 3.2.3 | SigmaWin+ Restrictions | 3-3 |
| 3.2.4 | Combining the SERVOPACKs with MP-Series Machine Controllers and the MPE720 Engineering Tool | 3-3 |
| 3.3 | Adjusting Less-Deviation Control 2 | 3-4 |
| 3.3.1 | Adjustment Procedure | 3-4 |
| 3.3.2 | Adjustment Example | 3-6 |
| 3.3.3 | Gain Switching Combinations | 3-9 |
| 3.3.4 | Method to Switch the Gain | 3-10 |
| 3.3.5 | Settings for Low-speed Feeding | 3-10 |
| 3.4 | Adjusting Less-Deviation Control 1 | 3-12 |
| 3.4.1 | Adjustment Procedure | 3-12 |
| 3.4.2 | Adjustment Example | 3-13 |
| 3.4.3 | Gain Switching Combinations | 3-14 |
| 3.4.4 | Method to Switch the Gain | 3-15 |
| 3.4.5 | Settings for Low-speed Feeding | 3-15 |
| 3.5 | Reference Compensation | 3-17 |
| 3.6 | Monitoring Machine Operation Status and Signal Waveforms . . | 3-18 |

4

Maintenance

| | | |
|------------|--|-------------|
| 4.1 | SERVOPACKs with Analog Voltage/Pulse Train References . . . | 4-2 |
| 4.1.1 | Alarm Displays | 4-2 |
| 4.1.2 | List of Alarms | 4-2 |
| 4.1.3 | Troubleshooting Alarms | 4-9 |
| 4.1.4 | Warning Displays | 4-38 |
| 4.1.5 | List of Warnings | 4-39 |
| 4.1.6 | Troubleshooting Warnings | 4-40 |
| 4.1.7 | Troubleshooting Based on the Operation and Conditions of the Servomotor | 4-46 |
| 4.2 | SERVOPACKs with MECHATROLINK-III Communications References . . . | 4-58 |
| 4.2.1 | Alarm Displays | 4-58 |
| 4.2.2 | List of Alarms | 4-58 |
| 4.2.3 | Troubleshooting Alarms | 4-64 |
| 4.2.4 | Warning Displays | 4-95 |
| 4.2.5 | List of Warnings | 4-96 |
| 4.2.6 | Troubleshooting Warnings | 4-98 |
| 4.2.7 | Troubleshooting Based on the Operation and Conditions of the Servomotor | 4-105 |

5

Parameter Lists

| | | |
|------------|---|-------------|
| 5.1 | SERVOPACKs with Analog Voltage/Pulse Train References . . . | 5-2 |
| 5.1.1 | Interpreting the Parameter Lists | 5-2 |
| 5.1.2 | List of Parameters | 5-3 |
| 5.1.3 | Parameter Recording Table | 5-36 |
| 5.2 | SERVOPACKs with MECHATROLINK-III Communications References . . | 5-44 |
| 5.2.1 | Interpreting the Parameter Lists | 5-44 |
| 5.2.2 | List of Servo Parameters | 5-45 |
| 5.2.3 | List of MECHATROLINK-III Common Parameters | 5-85 |
| 5.2.4 | Parameter Recording Table | 5-93 |

Index

Revision History

Basic Information on SERVOPACKs

1

This chapter provides information required to select SERVOPACKs, such as the SERVOPACK models.

| | | |
|------------|---|-------------|
| 1.1 | Product Introduction | 1-2 |
| 1.2 | Model Designations | 1-3 |
| 1.2.1 | Interpreting SERVOPACK Model Numbers | 1-3 |
| 1.2.2 | Interpreting Servomotor Model Numbers | 1-3 |
| 1.3 | Combinations of SERVOPACKs and Servomotors ... | 1-4 |
| 1.4 | Functions | 1-5 |
| 1.4.1 | SERVOPACK Functions | 1-5 |
| 1.4.2 | Functional Restrictions | 1-8 |
| 1.5 | SigmaWin+ | 1-9 |
| 1.6 | Combining the SERVOPACKs with MP-Series Machine Controllers and the MPE720 Engineering Tool .. | 1-10 |

1.1 Product Introduction

The FT19 SERVOPACKs use less-deviation control to perform tracking. There are the following two modes for less-deviation control. Set the mode in Pn195 = n.X□□□ (Less-Deviation Mode Selection).

| Less-Deviation Control Mode | Remarks |
|--|---|
| Less-Deviation Control 1 (Pn195 = n.0□□□) | Use this mode for compatibility with the Σ -V-EX-Series EX002 SERVO-PACKs. |
| Less-Deviation Control 2 (Pn195 = n.2□□□) | This mode reduces the maximum deviation and eliminates overshooting before reference distribution has been completed. Adjustments are possible for higher response than with Less-Deviation Control 1 Mode. |

Refer to the following chapter for details on less-deviation control.

 *Chapter 3 Less-Deviation Control (page 3-1)*

1.2 Model Designations

1.2.1 Interpreting SERVOPACK Model Numbers



1st+2nd+3rd digits Maximum Applicable Motor Capacity

| Voltage | Code | Specification |
|-----------------------|-------|---------------|
| Three-Phase, 200 VAC | R70*1 | 0.05 kW |
| | R90*1 | 0.1 kW |
| | 1R6*1 | 0.2 kW |
| | 2R8*1 | 0.4 kW |
| | 3R8 | 0.5 kW |
| | 5R5*1 | 0.75 kW |
| | 7R6 | 1.0 kW |
| | 120*2 | 1.5 kW |
| | 180 | 2.0 kW |
| | 200 | 3.0 kW |
| | 330 | 5.0 kW |
| | 470 | 6.0 kW |
| | 550 | 7.5 kW |
| 590 | 11 kW | |
| 780 | 15 kW | |
| Single-Phase, 100 VAC | R70 | 0.05 kW |
| | R90 | 0.1 kW |
| | 2R1 | 0.2 kW |
| | 2R8 | 0.4 kW |

4th digit Voltage

| Code | Specification |
|------|---------------|
| A | 200 VAC |
| F | 100 VAC |

5th+6th digits Interface*3

| Code | Specification |
|------|--|
| 00 | Analog voltage/pulse train reference |
| 20 | MECHATROLINK-III communications references |

7th digit Design Revision Order

A

8th+9th+10th digits Hardware Options Specification

| Code | Specification | Applicable Models |
|------|-----------------|-------------------|
| 000 | Without options | All models |

11th+12th+13th digits FT/EX Specification

| Code | Specification |
|------|---|
| F19 | Tracking application Built-in less-deviation control |

14th digit BTO Specification*4

| Code | Specification |
|------|-------------------|
| None | None |
| B | BTO specification |

*1. You can use these models with either a single-phase or three-phase input.
 *2. A model with a single-phase, 200-VAC power supply input is available as a hardware option (model: SGD7S-120A□□A008).
 *3. The same SERVOPACKs are used for both Rotary Servomotors and Linear Servomotors.
 *4. The BTO specification indicates if the SERVOPACK is customized by using the MechatroCloud BTO service. This service is available on the e-mechatronics website. You need a BTO number to order SERVOPACKs with customized specifications. Refer to the following catalog for details on the BTO specification.
 📖 AC Servo Drives Σ-7 Series (Catalog No.: KAEP S800001 23)

1.2.2 Interpreting Servomotor Model Numbers

Refer to the following manuals for information on interpreting Σ-7-Series Servomotor model numbers.

- 📖 Σ-7-Series Rotary Servomotor Product Manual (Manual No.: SIEP S800001 36)
- 📖 Σ-7-Series Linear Servomotor Product Manual (Manual No.: SIEP S800001 37)
- 📖 Σ-7-Series Direct Drive Servomotor Product Manual (Manual No.: SIEP S800001 38)

1.3 Combinations of SERVOPACKs and Servomotors

Refer to the following manuals for information on combinations with Σ -7-Series Servomotors.

 Σ -7-Series Rotary Servomotor Product Manual (Manual No.: SIEP S800001 36)

 Σ -7-Series Linear Servomotor Product Manual (Manual No.: SIEP S800001 37)

 Σ -7-Series Direct Drive Servomotor Product Manual (Manual No.: SIEP S800001 38)

1.4 Functions

This section lists the functions provided by SERVOPACKs. Refer to the following manuals for details on the functions.

📖 Σ -7-Series Σ -7S SERVOPACK with Analog Voltage/Pulse Train References Product Manual (Manual No.: SIEP S800001 26)

📖 Σ -7-Series Σ -7S SERVOPACK with MECHATROLINK-III Communications References Product Manual (Manual No.: SIEP S800001 28)

Functions given inside bold lines in the functions tables are restricted if less-deviation control is used for SERVOPACKs for tracking applications. Refer to the following section for details on restrictions to these functions.

📖 1.4.2 Functional Restrictions on page 1-8

1.4.1 SERVOPACK Functions

- Functions Related to the Machine

| Function |
|---|
| Power Supply Type Settings for the Main Circuit and Control Circuit |
| Automatic Detection of Connected Motor |
| Motor Direction Setting |
| Linear Encoder Pitch Setting |
| Writing Linear Servomotor Parameters |
| Selecting the Phase Sequence for a Linear Servomotor |
| Polarity Sensor Setting |
| Polarity Detection |
| Overtravel Function and Settings |
| Holding Brake |
| Motor Stopping Methods for Servo OFF and Alarms |
| Resetting the Absolute Encoder |
| Setting the Origin of the Absolute Encoder |
| Setting the Regenerative Resistor Capacity |
| Operation for Momentary Power Interruptions |
| SEMI F47 Function |
| Setting the Motor Maximum Speed |
| Software Limits and Settings* |
| Multiturn Limit Setting |
| Adjustment of Motor Current Detection Signal Offset |
| Forcing the Motor to Stop |
| Overheat Protection |
| Speed Ripple Compensation |
| Current Control Mode Selection |
| Current Gain Level Setting |
| Speed Detection Method Selection |
| Fully-Closed Loop Control |
| Safety Functions |
| External Latches* |

* These functions can be used with SERVOPACKs with MECHATROLINK-III Communications References.

• Functions Related to the Host Controller

| Function |
|--|
| Extended Address Setting |
| Electronic Gear Settings |
| I/O Signal Allocations |
| ALM (Servo Alarm) Signal |
| ALO1 to ALO3 (Alarm Code) Signals* |
| /WARN (Warning) Signal |
| /TGON (Rotation Detection) Signal |
| /S-RDY (Servo Ready) Signal |
| Speed Control* |
| Basic Settings for Speed Control* |
| Speed Reference Filter* |
| Zero Clamping* |
| /V-CMP (Speed Coincidence Detection) Signal |
| Position Control* |
| Reference Pulse Form* |
| CLR (Position Deviation Clear) Signal Function and Settings* |
| Reference Pulse Input Multiplication Switching* |
| /COIN (Positioning Completion) Signal |
| /NEAR (Near) Signal |
| Reference Pulse Inhibition and Settings* |
| Torque Control* |
| Basic Settings for Torque Control* |
| Torque Reference Filter Settings* |
| Speed Limit during Torque Control |
| /MLT (Speed Limit Detection) Signal |
| Encoder Divided Pulse Output |
| Selecting Torque Limits |
| Vibration Detection Level Initialization |
| Alarm Reset |
| Replacing the Battery |
| Setting the Position Deviation Overflow Alarm Level |

* These functions can be used with SERVOPACKs with Analog Voltage/Pulse Train References.

- Functions to Achieve Optimum Motions

| Function |
|-------------------------------------|
| Speed Control* ¹ |
| Soft Start Settings* ¹ |
| Position Control* ¹ |
| Smoothing Settings* ¹ |
| Torque Control* ¹ |
| Tuning-less Function |
| Autotuning without a Host Reference |
| Autotuning with a Host Reference |
| Custom Tuning |
| Anti-Resonance Control Adjustment |
| Vibration Suppression |
| Gain Selection |
| Friction Compensation |
| Gravity Compensation |
| Backlash Compensation* ² |
| Model Following Control |
| Compatible Adjustment Functions |
| Mechanical Analysis |
| Easy FFT |

*1. These functions can be used with SERVOPACKs with Analog Voltage/Pulse Train References.

*2. These functions can be used with SERVOPACKs with MECHATROLINK-III Communications References.

- Functions for Trial Operation during Setup

| Function |
|--|
| Software Reset |
| Trial Operation for the Servomotor without a Load |
| Program Jogging |
| Origin Search |
| Test without a Motor |
| Monitoring Machine Operation Status and Signal Waveforms |

- Functions for Inspection and Maintenance

| Function |
|--|
| Write Prohibition Setting for Parameters |
| Initializing Parameter Settings |
| Automatic Detection of Connected Motor |
| Monitoring Product Information |
| Monitoring Product Life |
| Alarm History Display |
| Alarm Tracing |

1.4.2 Functional Restrictions

There are restrictions to the following functions when less-deviation control is used.

| Function | Restriction |
|--|--|
| Tuning-less Function (Pn170 = n.□□□X) | The tuning-less function is given priority. Less-deviation control will be disabled even if you set the parameter for less-deviation control (Pn190 = n.□□□1). |
| Feedforward (Pn109) | This parameter cannot be used. Any parameter setting will be ignored. |
| Speed Loop Control Method (Pn10B = n.□□X□) | This parameter cannot be used with less-deviation control 2. Any parameter setting will be ignored. This parameter can be used with less-deviation control 1. |
| Automatic Gain Switching (Pn139 = n.□□□2) | This parameter cannot be used. Do not use it if less-deviation control is enabled. |
| Model Following Control (Pn140 = n.□□□X) | This parameter cannot be used. Any parameter setting will be ignored and less-deviation control will be given priority. |
| Reference Pulse Input Multiplier (Pn218) (This parameter is valid only for SERVO-PACKs with Analog Voltage/Pulse Train References.) | This parameter cannot be used. Any parameter setting will be ignored. |
| Tuning-less Level Setting (Fn200) | This function cannot be used. |
| Advanced Autotuning without Reference (Fn201) | This function cannot be used. |
| Advanced Autotuning with Reference (Fn202) | This function cannot be used. |
| One-Parameter Tuning (Fn203) | For less-deviation control 2, only Tuning Mode 5 can be used. For less-deviation control 1, only Tuning Mode 0 or 1 can be used. |
| Vibration Suppression (Fn205) | This function cannot be used. |

1.5 SigmaWin+

To use the SigmaWin+, a model information file for the SERVOPACK must be added to SigmaWin+ version 7. Contact your Yaskawa representative for the model information file.

1.6

Combining the SERVOPACKs with MP-Series Machine Controllers and the MPE720 Engineering Tool

If you combine the SERVOPACK with an MP-Series Machine Controller or the MPE720 Engineering Tool, it will be recognized as a SERVOPACK with standard specifications. To use the parameters that have been added or changed for the SERVOPACKs described in this manual, use the SigmaWin+.

SERVOPACK Ratings and Specifications

2

This chapter provides information required to select SERVOPACKs, such as specifications.

| | | |
|------------|---|------------|
| 2.1 | Ratings | 2-2 |
| 2.2 | SERVOPACK Overload Protection Characteristics .. | 2-5 |
| 2.3 | Specifications | 2-6 |
| 2.3.1 | SERVOPACKs with Analog Voltage/ Pulse Train References | 2-6 |
| 2.3.2 | SERVOPACKs with MECHATROLINK-III Communications References | 2-10 |

2.1 Ratings

This section gives the ratings of SERVOPACKs.

Three-Phase, 200 VAC

| Model SGD7S- | | R70A | R90A | 1R6A | 2R8A | 3R8A | 5R5A | 7R6A | 120A | 180A | 200A | 330A | |
|---|--|---|------|------|------|------|------|------|------|-------|-------|-------|-----|
| Maximum Applicable Motor Capacity [kW] | | 0.05 | 0.1 | 0.2 | 0.4 | 0.5 | 0.75 | 1.0 | 1.5 | 2.0 | 3.0 | 5.0 | |
| Continuous Output Current [Arms] | | 0.66 | 0.91 | 1.6 | 2.8 | 3.8 | 5.5 | 7.6 | 11.6 | 18.5 | 19.6 | 32.9 | |
| Instantaneous Maximum Output Current [Arms] | | 2.1 | 3.2 | 5.9 | 9.3 | 11 | 16.9 | 17 | 28 | 42 | 56 | 84 | |
| Main Circuit | Power Supply | 200 VAC to 240 VAC, -15% to +10%, 50 Hz/60 Hz | | | | | | | | | | | |
| | Input Current [Arms]* | 0.4 | 0.8 | 1.3 | 2.5 | 3.0 | 4.1 | 5.7 | 7.3 | 10 | 15 | 25 | |
| Control | Power Supply | 200 VAC to 240 VAC, -15% to +10%, 50 Hz/60 Hz | | | | | | | | | | | |
| | Input Current [Arms]* | 0.2 | 0.2 | 0.2 | 0.2 | 0.2 | 0.2 | 0.2 | 0.2 | 0.25 | 0.25 | 0.3 | |
| Power Supply Capacity [kVA]* | | 0.2 | 0.3 | 0.5 | 1.0 | 1.3 | 1.6 | 2.3 | 3.2 | 4.0 | 5.9 | 7.5 | |
| Power Loss* | Main Circuit Power Loss [W] | 5.0 | 7.0 | 11.9 | 22.5 | 28.5 | 38.9 | 49.2 | 72.6 | 104.2 | 114.2 | 226.6 | |
| | Control Circuit Power Loss [W] | 12 | 12 | 12 | 12 | 14 | 14 | 14 | 15 | 16 | 16 | 19 | |
| | Built-in Regenerative Resistor Power Loss [W] | – | – | – | – | 8 | 8 | 8 | 12 | 12 | 12 | 36 | |
| | Total Power Loss [W] | 17.0 | 19.0 | 23.9 | 34.5 | 50.5 | 60.9 | 71.2 | 97.6 | 136.2 | 146.2 | 281.6 | |
| Regenerative Resistor | Built-In Regenerative Resistor | Resistance [Ω] | – | – | – | – | 40 | 40 | 40 | 20 | 12 | 12 | 8 |
| | | Capacity [W] | – | – | – | – | 40 | 40 | 40 | 60 | 60 | 60 | 180 |
| | Minimum Allowable External Resistance [Ω] | 40 | 40 | 40 | 40 | 40 | 40 | 40 | 40 | 20 | 12 | 12 | 8 |
| Overvoltage Category | | III | | | | | | | | | | | |

* This is the net value at the rated load.

| Model SGD7S- | | 470A | 550A | 590A | 780A |
|---|--|---|--------------------|--------------------|--------------------|
| Maximum Applicable Motor Capacity [kW] | | 6.0 | 7.5 | 11 | 15 |
| Continuous Output Current [Arms] | | 46.9 | 54.7 | 58.6 | 78.0 |
| Instantaneous Maximum Output Current [Arms] | | 110 | 130 | 140 | 170 |
| Main Circuit | Power Supply | 200 VAC to 240 VAC, -15% to +10%, 50 Hz/60 Hz | | | |
| | Input Current [Arms] ^{*1} | 29 | 37 | 54 | 73 |
| Control | Power Supply | 200 VAC to 240 VAC, -15% to +10%, 50 Hz/60 Hz | | | |
| | Input Current [Arms] ^{*1} | 0.3 | 0.3 | 0.4 | 0.4 |
| Power Supply Capacity [kVA] ^{*1} | | 10.7 | 14.6 | 21.7 | 29.6 |
| Power Loss ^{*1} | Main Circuit Power Loss [W] | 271.7 | 326.9 | 365.3 | 501.4 |
| | Control Circuit Power Loss [W] | 21 | 21 | 28 | 28 |
| | External Regenerative Resistor Unit Power Loss [W] | 180 ^{*2} | 350 ^{*3} | 350 ^{*3} | 350 ^{*3} |
| | Total Power Loss [W] | 292.7 | 347.9 | 393.3 | 529.4 |
| External Regenerative Resistor Unit | Resistance [Ω] | 6.25 ^{*2} | 3.13 ^{*3} | 3.13 ^{*3} | 3.13 ^{*3} |
| | Capacity [W] | 880 ^{*2} | 1760 ^{*3} | 1760 ^{*3} | 1760 ^{*3} |
| | Minimum Allowable External Resistance [Ω] | 5.8 | 2.9 | 2.9 | 2.9 |
| Overvoltage Category | | III | | | |

*1. This is the net value at the rated load.

*2. This value is for the optional JUSP-RA04-E Regenerative Resistor Unit.

*3. This value is for the optional JUSP-RA05-E Regenerative Resistor Unit.

Single-Phase, 200 VAC

| Model SGD7S- | | R70A | R90A | 1R6A | 2R8A | 5R5A | 120A |
|---|--|---|------|------|------|------|-------|
| Maximum Applicable Motor Capacity [kW] | | 0.05 | 0.1 | 0.2 | 0.4 | 0.75 | 1.5 |
| Continuous Output Current [Arms] | | 0.66 | 0.91 | 1.6 | 2.8 | 5.5 | 11.6 |
| Instantaneous Maximum Output Current [Arms] | | 2.1 | 3.2 | 5.9 | 9.3 | 16.9 | 28 |
| Main Circuit | Power Supply | 200 VAC to 240 VAC, -15% to +10%, 50 Hz/60 Hz | | | | | |
| | Input Current [Arms]* | 0.8 | 1.6 | 2.4 | 5.0 | 8.7 | 16 |
| Control | Power Supply | 200 VAC to 240 VAC, -15% to +10%, 50 Hz/60 Hz | | | | | |
| | Input Current [Arms]* | 0.2 | 0.2 | 0.2 | 0.2 | 0.2 | 0.25 |
| Power Supply Capacity [kVA]* | | 0.2 | 0.3 | 0.6 | 1.2 | 1.9 | 4.0 |
| Power Loss* | Main Circuit Power Loss [W] | 5.0 | 7.1 | 12.1 | 23.7 | 39.2 | 71.8 |
| | Control Circuit Power Loss [W] | 12 | 12 | 12 | 12 | 14 | 16 |
| | Built-in Regenerative Resistor Power Loss [W] | – | – | – | – | 8 | 12 |
| | Total Power Loss [W] | 17.0 | 19.1 | 24.1 | 35.7 | 61.2 | 103.8 |
| Regenerative Resistor | Built-In Regenerative Resistor | Resistance [Ω] | – | – | – | 40 | 12 |
| | | Capacity [W] | – | – | – | 40 | 60 |
| | Minimum Allowable External Resistance [Ω] | 40 | 40 | 40 | 40 | 40 | 12 |
| Overvoltage Category | | III | | | | | |

* This is the net value at the rated load.

270 VDC

| Model SGD7S- | | R70A | R90A | 1R6A | 2R8A | 3R8A | 5R5A | 7R6A | 120A |
|---|------------------------------------|----------------------------------|------|------|------|------|------|------|-------------------|
| Maximum Applicable Motor Capacity [kW] | | 0.05 | 0.1 | 0.2 | 0.4 | 0.5 | 0.75 | 1.0 | 1.5 |
| Continuous Output Current [Arms] | | 0.66 | 0.91 | 1.6 | 2.8 | 3.8 | 5.5 | 7.6 | 11.6 |
| Instantaneous Maximum Output Current [Arms] | | 2.1 | 3.2 | 5.9 | 9.3 | 11.0 | 16.9 | 17.0 | 28.0 |
| Main Circuit | Power Supply | 270 VDC to 324 VDC, -15% to +10% | | | | | | | |
| | Input Current [Arms] ^{*1} | 0.5 | 1.0 | 1.5 | 3.0 | 3.8 | 4.9 | 6.9 | 11 |
| Control | Power Supply | 270 VDC to 324 VDC, -15% to +10% | | | | | | | |
| | Input Current [Arms] ^{*1} | 0.2 | 0.2 | 0.2 | 0.2 | 0.2 | 0.2 | 0.2 | 0.2 ^{*2} |
| Power Supply Capacity [kVA] ^{*1} | | 0.2 | 0.3 | 0.6 | 1 | 1.4 | 1.6 | 2.3 | 3.2 |
| Power Loss ^{*1} | Main Circuit Power Loss [W] | 4.4 | 5.9 | 9.8 | 17.5 | 23.0 | 30.7 | 38.7 | 55.8 |
| | Control Circuit Power Loss [W] | 12 | 12 | 12 | 12 | 14 | 14 | 14 | 15 |
| | Total Power Loss [W] | 16.4 | 17.9 | 21.8 | 29.5 | 37.0 | 44.7 | 52.7 | 70.8 |
| Overvoltage Category | | III | | | | | | | |

*1. This is the net value at the rated load.

*2. The value is 0.25 Arms for the SGD7S-120A00A008.

| Model SGD7S- | | 180A | 200A | 330A | 470A | 550A | 590A | 780A |
|---|--------------------------------|----------------------------------|------|-------|-------|-------|-------|-------|
| Maximum Applicable Motor Capacity [kW] | | 2.0 | 3.0 | 5.0 | 6.0 | 7.5 | 11.0 | 15.0 |
| Continuous Output Current [Arms] | | 18.5 | 19.6 | 32.9 | 46.9 | 54.7 | 58.6 | 78.0 |
| Instantaneous Maximum Output Current [Arms] | | 42.0 | 56.0 | 84.0 | 110 | 130 | 140 | 170 |
| Main Circuit | Power Supply | 270 VDC to 324 VDC, -15% to +10% | | | | | | |
| | Input Current [Arms]* | 14 | 20 | 34 | 36 | 48 | 68 | 92 |
| Control | Power Supply | 270 VDC to 324 VDC, -15% to +10% | | | | | | |
| | Input Current [Arms]* | 0.25 | 0.25 | 0.3 | 0.3 | 0.3 | 0.4 | 0.4 |
| Power Supply Capacity [kVA]* | | 4.0 | 5.9 | 7.5 | 10.7 | 14.6 | 21.7 | 29.6 |
| Power Loss* | Main Circuit Power Loss [W] | 82.7 | 83.5 | 146.2 | 211.6 | 255.3 | 243.6 | 343.4 |
| | Control Circuit Power Loss [W] | 16 | 16 | 19 | 21 | 21 | 28 | 28 |
| | Total Power Loss [W] | 98.7 | 99.5 | 165.2 | 232.6 | 276.3 | 271.6 | 371.4 |
| Overvoltage Category | | III | | | | | | |

* This is the net value at the rated load.

Single-Phase, 100 VAC

| Model SGD7S- | | R70F | R90F | 2R1F | 2R8F |
|---|---|---|------|------|------|
| Maximum Applicable Motor Capacity [kW] | | 0.05 | 0.1 | 0.2 | 0.4 |
| Continuous Output Current [Arms] | | 0.66 | 0.91 | 2.1 | 2.8 |
| Instantaneous Maximum Output Current [Arms] | | 2.1 | 3.2 | 6.5 | 9.3 |
| Main Circuit | Power Supply | 100 VAC to 120 VAC, -15% to +10%, 50 Hz/60 Hz | | | |
| | Input Current [Arms]* | 1.5 | 2.5 | 5 | 10 |
| Control | Power Supply | 100 VAC to 120 VAC, -15% to +10%, 50 Hz/60 Hz | | | |
| | Input Current [Arms]* | 0.38 | 0.38 | 0.38 | 0.38 |
| Power Supply Capacity [kVA]* | | 0.2 | 0.3 | 0.6 | 1.4 |
| Power Loss* | Main Circuit Power Loss [W] | 5.3 | 7.8 | 14.2 | 26.2 |
| | Control Circuit Power Loss [W] | 12 | 12 | 12 | 12 |
| | Total Power Loss [W] | 17.3 | 19.8 | 26.2 | 38.2 |
| Regenerative Resistor | Minimum Allowable Resistance [Ω] | 40 | 40 | 40 | 40 |
| Overvoltage Category | | III | | | |

* This is the net value at the rated load.

2.2 SERVOPACK Overload Protection Characteristics

The overload detection level is set for hot start conditions with a SERVOPACK surrounding air temperature of 55°C.

An overload alarm (A.710 or A.720) will occur if overload operation that exceeds the overload protection characteristics shown in the following diagram (i.e., operation on the right side of the applicable line) is performed.

The actual overload detection level will be the detection level of the connected SERVOPACK or Servomotor that has the lower overload protection characteristics.

In most cases, that will be the overload protection characteristics of the Servomotor.

- SGD7S-R70A, -R90A, -1R6A, -2R8A, -R70F, -R90F, -2R1F, and -2R8F

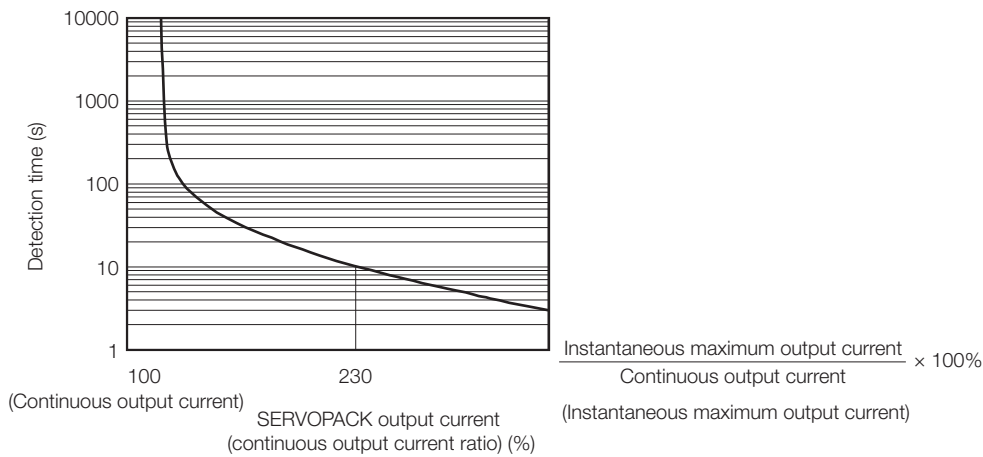

Note: The above overload protection characteristics do not mean that you can perform continuous duty operation with an output of 100% or higher.

For a Yaskawa-specified combination of SERVOPACK and Servomotor, maintain the effective torque within the continuous duty zone of the torque-motor speed characteristic of the Servomotor.

- SGD7S-3R8A, -5R5A, -7R6A, -120A, -180A, -200A, -330A, -470A, -550A, -590A, and -780A

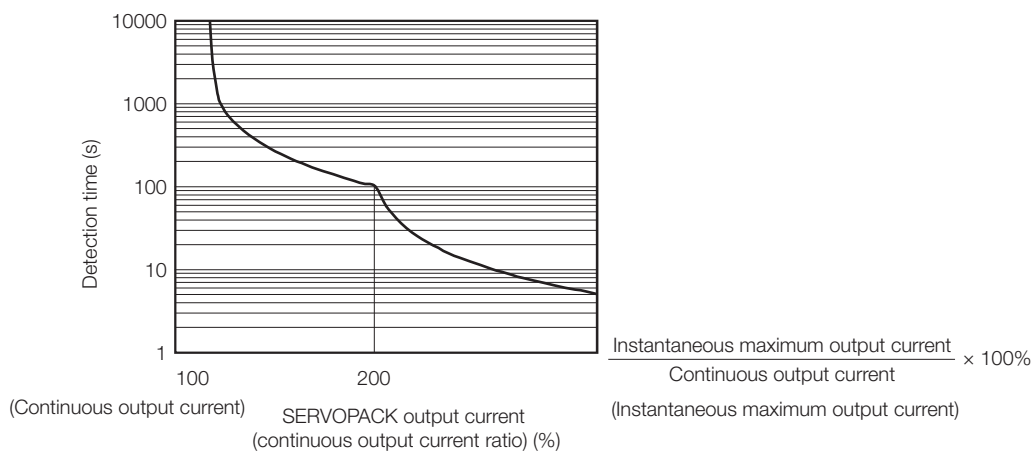

Note: The above overload protection characteristics do not mean that you can perform continuous duty operation with an output of 100% or higher.

For a Yaskawa-specified combination of SERVOPACK and Servomotor, maintain the effective torque within the continuous duty zone of the torque-motor speed characteristic of the Servomotor.

2.3 Specifications

This section gives the general specifications of SERVOPACKs.

2.3.1 SERVOPACKs with Analog Voltage/Pulse Train References

| Item | | Specification | | | | | | |
|--------------------------|---|---|--------|-------------------------|------|--|------|--|
| Control Method | | IGBT-based PWM control, sine wave current drive | | | | | | |
| Feedback | With Rotary Servomotor | Serial encoder: 17 bits (absolute encoder) 20 bits or 24 bits (incremental encoder/absolute encoder) 22 bits (absolute encoder) | | | | | | |
| | With Linear Servomotor | <ul style="list-style-type: none"> Absolute linear encoder (The signal resolution depends on the absolute linear encoder.) Incremental linear encoder (The signal resolution depends on the incremental linear encoder or Serial Converter Unit.) | | | | | | |
| Environmental Conditions | Surrounding Air Temperature* ¹ | -5°C to 55°C (With derating, usage is possible between 55°C and 60°C.) Refer to the following manual for derating specifications. Σ-7-Series Σ-7S SERVOPACK with Analog Voltage/Pulse Train References Product Manual (Manual No.: SIEP S800001 26) | | | | | | |
| | Storage Temperature | -20°C to 85°C | | | | | | |
| | Surrounding Air Humidity | 95% relative humidity max. (with no freezing or condensation) | | | | | | |
| | Storage Humidity | 95% relative humidity max. (with no freezing or condensation) | | | | | | |
| | Vibration Resistance | 4.9 m/s ² | | | | | | |
| | Shock Resistance | 19.6 m/s ² | | | | | | |
| | Degree of Protection | <table border="1"> <thead> <tr> <th>Degree</th> <th>SERVOPACK Model: SGD7S-</th> </tr> </thead> <tbody> <tr> <td>IP20</td> <td>R70A, R90A, 1R6A, 2R8A, 3R8A, 5R5A, 7R6A, 120A, R70F, R90F, 2R1F, 2R8F</td> </tr> <tr> <td>IP10</td> <td>120A00A008, 180A, 200A, 330A, 470A, 550A, 590A, 780A</td> </tr> </tbody> </table> | Degree | SERVOPACK Model: SGD7S- | IP20 | R70A, R90A, 1R6A, 2R8A, 3R8A, 5R5A, 7R6A, 120A, R70F, R90F, 2R1F, 2R8F | IP10 | 120A00A008, 180A, 200A, 330A, 470A, 550A, 590A, 780A |
| | Degree | SERVOPACK Model: SGD7S- | | | | | | |
| | IP20 | R70A, R90A, 1R6A, 2R8A, 3R8A, 5R5A, 7R6A, 120A, R70F, R90F, 2R1F, 2R8F | | | | | | |
| | IP10 | 120A00A008, 180A, 200A, 330A, 470A, 550A, 590A, 780A | | | | | | |
| Pollution Degree | 2 <ul style="list-style-type: none"> Must be no corrosive or flammable gases. Must be no exposure to water, oil, or chemicals. Must be no dust, salts, or iron dust. | | | | | | | |
| Altitude* ¹ | 1,000 m max. (With derating, usage is possible between 1,000 m and 2,000 m.) Refer to the following manual for derating specifications. Σ-7-Series Σ-7S SERVOPACK with Analog Voltage/Pulse Train References Product Manual (Manual No.: SIEP S800001 26) | | | | | | | |
| Others | Do not use the SERVOPACK in the following locations: Locations subject to static electricity noise, strong electromagnetic/magnetic fields, or radioactivity | | | | | | | |
| Applicable Standards | | Refer to the following section for details. Compliance with UL Standards, EU Directives, and Other Safety Standards on page xxvii | | | | | | |
| Mounting | Mounting | SERVOPACK Model: SGD7S- | | | | | | |
| | Base-mounted | All Models | | | | | | |
| | Rack-mounted | R70A, R90A, 1R6A, 2R8A, 3R8A, 5R5A, 7R6A, 120A, 180A, 200A, 330A, R70F, R90F, 2R1F, 2R8F | | | | | | |
| | Duct-ventilated | 470A, 550A, 590A, 780A | | | | | | |

Continued on next page.

Continued from previous page.

| Item | | Specification | |
|--|--|---|---|
| Performance | Speed Control Range | 1:5000 (At the rated torque, the lower limit of the speed control range must not cause the Servomotor to stop.) | |
| | Coefficient of Speed Fluctuation* ² | ±0.01% of rated speed max. (for a load fluctuation of 0% to 100%) | |
| | | 0% of rated speed max. (for a load fluctuation of ±10%) | |
| | | ±0.1% of rated speed max. (for a temperature fluctuation of 25°C ±25°C) | |
| Torque Control Precision (Repeatability) | ±1% | | |
| Soft Start Time Setting | 0 s to 10 s (Can be set separately for acceleration and deceleration.) | | |
| I/O Signals | Encoder Divided Pulse Output | Phase A, phase B, phase C: Line-driver output Number of divided output pulses: Any setting is allowed. | |
| | Overheat Protection Input | Number of input points: 1 Input voltage range: 0 V to +5 V | |
| | Sequence Input Signals | Fixed Input | Allowable voltage range: 5 VDC ±5% Number of input points: 1 SEN (Absolute Data Request) signal |
| | | Input Signals That Can Be Allocated | Allowable voltage range: 24 VDC ±20% Number of input points: 7 (Input method: Sink inputs or source inputs) |
| | | | Input Signals |

Continued on next page.

2.3 Specifications

2.3.1 SERVOPACKs with Analog Voltage/Pulse Train References

Continued from previous page.

| Item | | Specification | |
|----------------------------|------------------------------|--|---|
| I/O Signals | Sequence Output Signals | Fixed Output | Allowable voltage range: 5 VDC to 30 VDC Number of output points: 1 (A photocoupler output (isolated) is used.) Output signal: ALM (Servo Alarm) signal |
| | | Output Signals That Can Be Allocated | Allowable voltage range: 5 VDC to 30 VDC Number of output points: 6 (A photocoupler output (isolated) is used for three of the outputs.) (An open-collector output (non-isolated) is used for the other three outputs.) Output Signals <ul style="list-style-type: none"> • /COIN (Positioning Completion) signal • /V-CMP (Speed Coincidence Detection) signal • /TGON (Rotation Detection) signal • /S-RDY (Servo Ready) signal • /CLT (Torque Limit Detection) signal • /VLT (Speed Limit Detection) signal • /BK (Brake) signal • /WARN (Warning) signal • /NEAR (Near) signal • /PSELA (Reference Pulse Input Multiplication Switching Output) signal • ALO1, ALO2, and ALO3 (Alarm Code) signals A signal can be allocated and the positive and negative logic can be changed. |
| Communications | RS-422A Communications (CN3) | Inter-faces | Digital Operator (JUSP-OP05A-1-E) and personal computer (with SigmaWin+) |
| | | 1:N Communications | Up to N = 15 stations possible for RS-422A port |
| | | Axis Address Setting | Set with parameters. |
| | USB Communications (CN7) | Interface | Personal computer (with SigmaWin+) |
| Communications Standard | | Conforms to USB2.0 standard (12 Mbps). | |
| Displays/Indicators | | CHARGE indicator and five-digit seven-segment display | |
| Panel Operator | | Four push switches | |
| Analog Monitor (CN5) | | Number of points: 2 Output voltage range: ± 10 VDC (effective linearity range: ± 8 V) Resolution: 16 bits Accuracy: ± 20 mV (Typ) Maximum output current: ± 10 mA Settling time ($\pm 1\%$): 1.2 ms (Typ) | |
| Dynamic Brake (DB) | | Activated when a servo alarm or overtravel (OT) occurs, or when the power supply to the main circuit or servo is OFF. | |
| Regenerative Processing | | Built-in (An external resistor must be connected to the SGD7S-470A to -780A.) Refer to the following catalog for details.  AC Servo Drives Σ -7 Series (Manual No.: KAEP S800001 23) | |
| Overtravel (OT) Prevention | | Stopping with dynamic brake, deceleration to a stop, or coasting to a stop for the P-OT (Forward Drive Prohibit) or N-OT (Reverse Drive Prohibit) signal | |
| Protective Functions | | Overcurrent, overvoltage, low voltage, overload, regeneration error, etc. | |
| Utility Functions | | Gain adjustment, alarm history, jogging, origin search, etc. | |

Continued on next page.

Continued from previous page.

| Item | | Specification | | | |
|--------------------------------|------------------------|---|--|---|--|
| Safety Functions | Inputs | /HWBB1 and /HWBB2: Base block signals for Power Modules | | | |
| | Output | EDM1: Monitors the status of built-in safety circuit (fixed output). | | | |
| | Applicable Standards*3 | ISO13849-1 PLe (Category 3) and IEC61508 SIL3 | | | |
| Applicable Option Modules | | Fully-closed Modules and Safety Modules Note: You cannot use a Fully-closed Module and a Safety Module together. | | | |
| Controls | Speed Control | Soft Start Time Setting | | 0 s to 10 s (Can be set separately for acceleration and deceleration.) | |
| | | Input Signal | Reference Voltage | <ul style="list-style-type: none"> Maximum input voltage: ± 12 V (forward motor rotation for positive reference). 6 VDC at rated speed (default setting). Input gain setting can be changed. | |
| | | | Input Impedance | Approx. 14 k Ω | |
| | | | Circuit Time Constant | 30 μ s | |
| | | Internal Set Speed Control | Rotation Direction Selection | With Proportional Control signal | |
| | Speed Selection | | With Forward/Reverse External Torque Limit signals (speed 1 to 3 selection). Servomotor stops or another control method is used when both signals are OFF. | | |
| | Position Control | Feedforward Compensation | | 0% to 100% | |
| | | Output Signal Positioning Completed Width Setting | | 0 to 1,073,741,824 reference units | |
| | | Input Signals | Reference Pulses | Reference Pulse Form | One of the following is selected: Sign + pulse train, CW + CCW pulse trains, and two-phase pulse trains with 90° phase differential |
| | | | | Input Form | Line driver or open collector |
| Maximum Input Frequency | | | Line Driver | Sign + pulse train or CW + CCW pulse trains: 4 Mpps Two-phase pulse trains with 90° phase differential: 1 Mpps | |
| | | | Open Collector | Sign + pulse train or CW + CCW pulse trains: 200 kpps Two-phase pulse trains with 90° phase differential: 200 kpps | |
| Input Multiplication Switching | 1 to 100 times | | | | |
| Clear Signal | | Position deviation clear Line driver or open collector | | | |

Continued on next page.

2.3 Specifications

2.3.2 SERVOPACKs with MECHATROLINK-III Communications References

Continued from previous page.

| Item | | | Specification |
|----------|----------------|-------------------|---|
| Controls | Torque Control | Input Signal | <ul style="list-style-type: none"> Maximum input voltage: ± 12 V (forward torque output for positive reference). 3 VDC at rated torque (default setting). Input gain setting can be changed. |
| | | Reference Voltage | Approx. 14 k Ω |
| | | Input Impedance | 16 μ s |

*1. If you combine a Σ -7-Series SERVOPACK with a Σ -V-Series Option Module, the following Σ -V-Series SERVOPACKs specifications must be used: a surrounding air temperature of 0°C to 55°C and an altitude of 1,000 m max. Also, the applicable surrounding range cannot be increased by derating.

*2. The coefficient of speed fluctuation for load fluctuation is defined as follows:

$$\text{Coefficient of speed fluctuation} = \frac{\text{No-load motor speed} - \text{Total-load motor speed}}{\text{Rated motor speed}} \times 100\%$$



*3. Always perform risk assessment for the system and confirm that the safety requirements are met.

2.3.2 SERVOPACKs with MECHATROLINK-III Communications References

| Item | | Specification | |
|--------------------------|---|---|--|
| Control Method | | IGBT-based PWM control, sine wave current drive | |
| Feedback | With Rotary Servomotor | Serial encoder: 17 bits (absolute encoder) 20 bits or 24 bits (incremental encoder/absolute encoder) 22 bits (absolute encoder) | |
| | With Linear Servomotor | <ul style="list-style-type: none"> Absolute linear encoder (The signal resolution depends on the absolute linear encoder.) Incremental linear encoder (The signal resolution depends on the incremental linear encoder or Serial Converter Unit.) | |
| Environmental Conditions | Surrounding Air Temperature* ¹ | -5°C to 55°C (With derating, usage is possible between 55°C and 60°C.) Refer to the following manual for derating specifications.  Σ -7-Series Σ -7S SERVOPACK with MECHATROLINK-III Communications References Product Manual (Manual No.: SIEP S800001 28) | |
| | Storage Temperature | -20°C to 85°C | |
| | Surrounding Air Humidity | 95% relative humidity max. (with no freezing or condensation) | |
| | Storage Humidity | 95% relative humidity max. (with no freezing or condensation) | |
| | Vibration Resistance | 4.9 m/s ² | |
| | Shock Resistance | 19.6 m/s ² | |
| | Degree of Protection | Degree | SERVOPACK Model: SGD7S- |
| | | IP20 | R70A, R90A, 1R6A, 2R8A, 3R8A, 5R5A, 7R6A, 120A, R70F, R90F, 2R1F, 2R8F |
| IP10 | | 120A20A008, 180A, 200A, 330A, 470A, 550A, 590A, 780A | |
| Pollution Degree | 2 <ul style="list-style-type: none"> Must be no corrosive or flammable gases. Must be no exposure to water, oil, or chemicals. Must be no dust, salts, or iron dust. | | |

Continued on next page.

Continued from previous page.

| Item | | Specification |
|--|--|---|
| Environmental Conditions | Altitude* ¹ | 1,000 m max. (With derating, usage is possible between 1,000 m and 2,000 m.) Refer to the following manual for derating specifications.  Σ -7-Series Σ -7S SERVOPACK with MECHATROLINK-III Communications References Product Manual (Manual No.: SIEP S800001 28) |
| | Others | Do not use the SERVOPACK in the following locations: Locations subject to static electricity noise, strong electromagnetic/magnetic fields, or radioactivity |
| Applicable Standards | | Refer to the following section for details.  <i>Compliance with UL Standards, EU Directives, and Other Safety Standards on page xxvii</i> |
| Mounting | Mounting | |
| | Base-mounted | SERVOPACK Model: SGD7S- All Models |
| | Rack-mounted | R70A, R90A, 1R6A, 2R8A, 3R8A, 5R5A, 7R6A, 120A, 180A, 200A, 330A, R70F, R90F, 2R1F, 2R8F |
| | Duct-ventilated | 470A, 550A, 590A, 780A |
| Performance | Speed Control Range | 1:5000 (At the rated torque, the lower limit of the speed control range must not cause the Servomotor to stop.) |
| | Coefficient of Speed Fluctuation* ² | $\pm 0.01\%$ of rated speed max. (for a load fluctuation of 0% to 100%) |
| | | 0% of rated speed max. (for a load fluctuation of $\pm 10\%$) |
| | | $\pm 0.1\%$ of rated speed max. (for a temperature fluctuation of 25°C $\pm 25^\circ\text{C}$) |
| Torque Control Precision (Repeatability) | $\pm 1\%$ | |
| Soft Start Time Setting | 0 s to 10 s (Can be set separately for acceleration and deceleration.) | |
| I/O Signals | Encoder Divided Pulse Output | Phase A, phase B, phase C: Line-driver output Number of divided output pulses: Any setting is allowed. |
| | Overheat Protection Input | Number of input points: 1 Input voltage range: 0 V to +5 V |
| | Sequence Input Signals | Input Signals That Can Be Allocated Allowable voltage range: 24 VDC $\pm 20\%$ Number of input points: 7 (Input method: Sink inputs or source inputs) Input Signals <ul style="list-style-type: none"> • P-OT (Forward Drive Prohibit) and N-OT (Reverse Drive Prohibit) signals • /P-CL (Forward External Torque Limit) and /N-CL (Reverse External Torque Limit) signals • /DEC (Origin Return Deceleration Switch) signal • /EXT1 to /EXT3 (External Latch Input 1 to 3) signals • FSTP (Forced Stop Input) signal A signal can be allocated and the positive and negative logic can be changed. |

Continued on next page.

2.3 Specifications

2.3.2 SERVOPACKs with MECHATROLINK-III Communications References

Continued from previous page.

| Item | | Specification | |
|--|-------------------------------------|--|--|
| I/O Signals | Sequence Output Signals | Fixed Output | Allowable voltage range: 5 VDC to 30 VDC Number of output points: 1 (A photocoupler output (isolated) is used.) Output signal: ALM (Servo Alarm) signal |
| | | Output Signals That Can Be Allocated | Allowable voltage range: 5 VDC to 30 VDC Number of output points: 3 (A photocoupler output (isolated) is used.) Output Signals <ul style="list-style-type: none"> • /COIN (Positioning Completion) signal • /V-CMP (Speed Coincidence Detection) signal • /TGON (Rotation Detection) signal • /S-RDY (Servo Ready) signal • /CLT (Torque Limit Detection) signal • /VLT (Speed Limit Detection) signal • /BK (Brake) signal • /WARN (Warning) signal • /NEAR (Near) signal A signal can be allocated and the positive and negative logic can be changed. |
| Communications | RS-422A Communications (CN3) | Inter- faces | Digital Operator (JUSP-OP05A-1-E) and personal computer (with SigmaWin+) |
| | | 1:N Communi- cations | Up to N = 15 stations possible for RS-422A port |
| | | Axis Address Setting | 03h to EFh (maximum number of slaves: 62) The rotary switches (S1 and S2) are used to set the station address. |
| | USB Communi- cations (CN7) | Interface | Personal computer (with SigmaWin+) |
| Communi- cations Standard | | Conforms to USB2.0 standard (12 Mbps). | |
| Displays/Indicators | | CHARGE, PWR, CN, L1, and L2 indicators, and one-digit seven-segment display | |
| MECHA- TROLINK-III Communi- cations | Communications Protocol | MECHATROLINK-III | |
| | Station Address Settings | 03h to EFh (maximum number of slaves: 62) The rotary switches (S1 and S2) are used to set the station address. | |
| | Baud Rate | 100 Mbps | |
| | Transmission Cycle | 125 μ s, 250 μ s, 500 μ s, 750 μ s, 1.0 ms to 4.0 ms (multiples of 0.5 ms) | |
| | Number of Transmission Bytes | 32 or 48 bytes/station A DIP switch (S3) is used to select the number of transmission bytes. | |
| Reference Method | Performance | Position, speed, or torque control with MECHATROLINK-III communications | |
| | Reference Input | MECHATROLINK-III commands (sequence, motion, data setting, data access, monitoring, adjustment, etc.) | |
| | Profile | MECHATROLINK-III standard servo profile | |
| MECHATROLINK-III Communications Setting Switches | | Rotary switch (S1 and S2) positions: 16 Number of DIP switch (S3) pins: 4 | |
| Analog Monitor (CN5) | | Number of points: 2 Output voltage range: \pm 10 VDC (effective linearity range: \pm 8 V) Resolution: 16 bits Accuracy: \pm 20 mV (Typ) Maximum output current: \pm 10 mA Settling time (\pm 1%): 1.2 ms (Typ) | |
| Dynamic Brake (DB) | | Activated when a servo alarm or overtravel (OT) occurs, or when the power supply to the main circuit or servo is OFF. | |

Continued on next page.

Continued from previous page.

| Item | Specification | |
|----------------------------|--|--|
| Regenerative Processing | Built-in (An external resistor must be connected to the SGD7S-470A to -780A.) Refer to the following catalog for details. 📖 AC Servo Drives Σ -7 Series (Manual No.: KAEP S800001 23) | |
| Overtravel (OT) Prevention | Stopping with dynamic brake, deceleration to a stop, or coasting to a stop for the P-OT (Forward Drive Prohibit) or N-OT (Reverse Drive Prohibit) signal | |
| Protective Functions | Overcurrent, overvoltage, low voltage, overload, regeneration error, etc. | |
| Utility Functions | Gain adjustment, alarm history, jogging, origin search, etc. | |
| Safety Functions | Inputs | /HWBB1 and /HWBB2: Base block signals for Power Modules |
| | Output | EDM1: Monitors the status of built-in safety circuit (fixed output). |
| | Applicable Standards*3 | ISO13849-1 PLe (Category 3), IEC61508 SIL3 |
| Applicable Option Modules | Fully-closed Modules and Safety Modules Note: You cannot use a Fully-closed Module and a Safety Module together. | |

*1. If you combine a Σ -7-Series SERVOPACK with a Σ -V-Series Option Module, the following Σ -V-Series SERVO-PACKs specifications must be used: a surrounding air temperature of 0°C to 55°C and an altitude of 1,000 m max. Also, the applicable surrounding range cannot be increased by derating.

*2. The coefficient of speed fluctuation for load fluctuation is defined as follows:

$$\text{Coefficient of speed fluctuation} = \frac{\text{No-load motor speed} - \text{Total-load motor speed}}{\text{Rated motor speed}} \times 100\%$$

*3. Always perform risk assessment for the system and confirm that the safety requirements are met.

Less-Deviation Control

3

This chapter describes less-deviation control.

| | | |
|------------|---|-------------|
| 3.1 | Introduction | 3-2 |
| 3.2 | Restrictions | 3-3 |
| 3.2.1 | Control Mode Restrictions | 3-3 |
| 3.2.2 | Functional Restrictions | 3-3 |
| 3.2.3 | SigmaWin+ Restrictions | 3-3 |
| 3.2.4 | Combining the SERVOPACKs with MP-Series Machine Controllers and the MPE720 Engineering Tool | 3-3 |
| 3.3 | Adjusting Less-Deviation Control 2 | 3-4 |
| 3.3.1 | Adjustment Procedure | 3-4 |
| 3.3.2 | Adjustment Example | 3-6 |
| 3.3.3 | Gain Switching Combinations | 3-9 |
| 3.3.4 | Method to Switch the Gain | 3-10 |
| 3.3.5 | Settings for Low-speed Feeding | 3-10 |
| 3.4 | Adjusting Less-Deviation Control 1 | 3-12 |
| 3.4.1 | Adjustment Procedure | 3-12 |
| 3.4.2 | Adjustment Example | 3-13 |
| 3.4.3 | Gain Switching Combinations | 3-14 |
| 3.4.4 | Method to Switch the Gain | 3-15 |
| 3.4.5 | Settings for Low-speed Feeding | 3-15 |
| 3.5 | Reference Compensation | 3-17 |
| 3.6 | Monitoring Machine Operation Status and Signal Waveforms | 3-18 |

3.1 Introduction

You can use less-deviation control to reduce the deviation during movement and increase the locus tracking performance. The FT19 SERVOPACKs are used for applications that require reference tracking performance during movement, including the decrease of tracking error and the prevention of interference between the equipment and moving parts, which can be caused by the influences of position response delay.

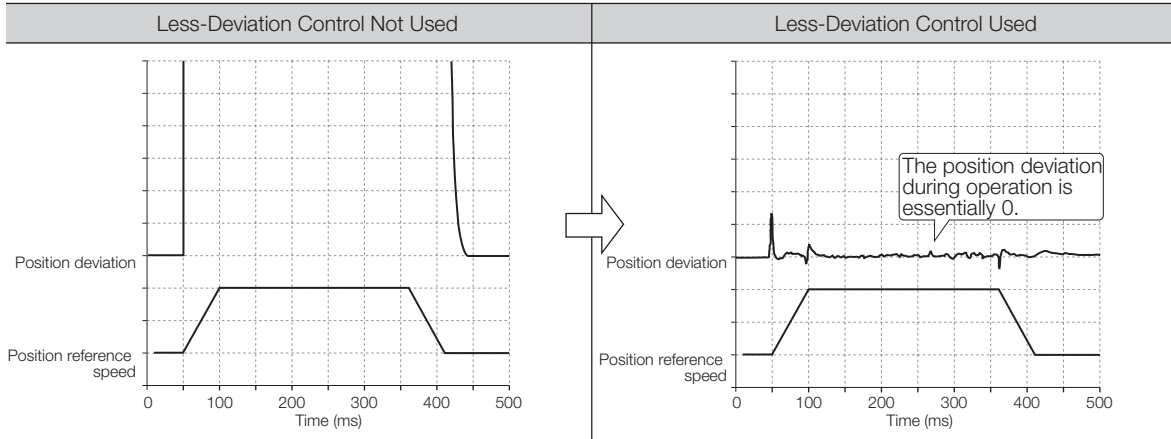

Less-deviation control is enabled or disabled with Pn190 = n.□□□X.

- Pn190 = n.□□□1: Use less-deviation control.
- Pn190 = n.□□□0: Do not use less-deviation control.

Adjusting less-deviation control depends on the less-deviation control mode that you use.

- Less-Deviation Control 1 (Pn195 = n.0□□□): Pn193 and Pn191
- Less-Deviation Control 2 (Pn195 = n.2□□□): Custom Tuning on the SigmaWin+

An outline of the control block diagram for Less-Deviation Control 2 is given below.

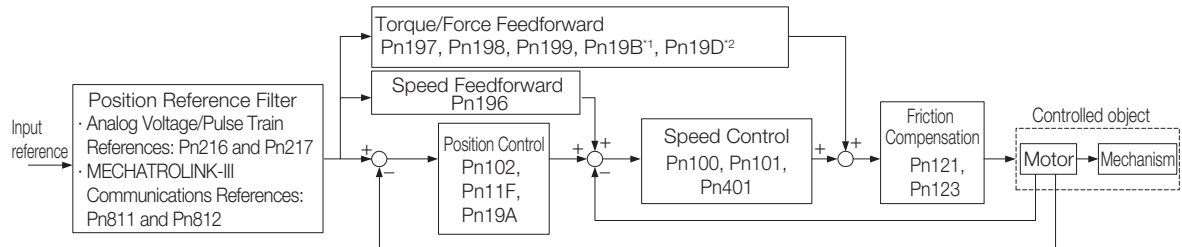

*1. These parameters are used for adjustments for Rotary Servomotors.
 *2. These parameters are used for adjustments for Linear Servomotors.

Important If you use less-deviation control under any of the following conditions, vibration, noise, or overshooting may occur.

- Condition 1: The machine has low rigidity. (Guideline: There is a large resonance point in the frequency band from 300 Hz and lower.)
- Condition 2: The machine has large variations in the load.
- Condition 3: The resolution of the encoder is low.

If the condition 1 or 2 is met, do not use less-deviation control. If the condition 3 is met, we recommend using a motor with an encoder that has a resolution of 20 bits or higher. Also, for fully-closed loop control, we recommend using a linear scale (external encoder) that has a resolution equivalent to the motor encoder.

Important The optimum feedforward is set inside the SERVOPACK for less-deviation control. A speed feedforward input or torque feedforward input from the host controller is normally not used at the same time as less-deviation control. However, they can be used together with less-deviation control if necessary. If they are used together and an inappropriate feedforward value is input, overshooting may occur.

3.2 Restrictions

3.2.1 Control Mode Restrictions

Less-deviation control can be used only in Position Control Mode. It cannot be used in Speed Control Mode or Torque Control Mode.

If you change from Speed Control Mode or Torque Control Mode to Position Control Mode, less-deviation control will be enabled after the motor stops.

3.2.2 Functional Restrictions

Refer to the following section for details on restrictions to these functions.

 1.4.2 *Functional Restrictions* on page 1-8

3.2.3 SigmaWin+ Restrictions

Refer to the following section for details on restrictions to the SigmaWin+.

 1.5 *SigmaWin+* on page 1-9

3.2.4 Combining the SERVOPACKs with MP-Series Machine Controllers and the MPE720 Engineering Tool

Refer to the following section for applications restrictions when the SERVOPACK is combined with an MP-Series Machine Controller or the MPE720 Engineering Tool.



 1.6 *Combining the SERVOPACKs with MP-Series Machine Controllers and the MPE720 Engineering Tool* on page 1-10

3.3 Adjusting Less-Deviation Control 2

3.3.1 Adjustment Procedure

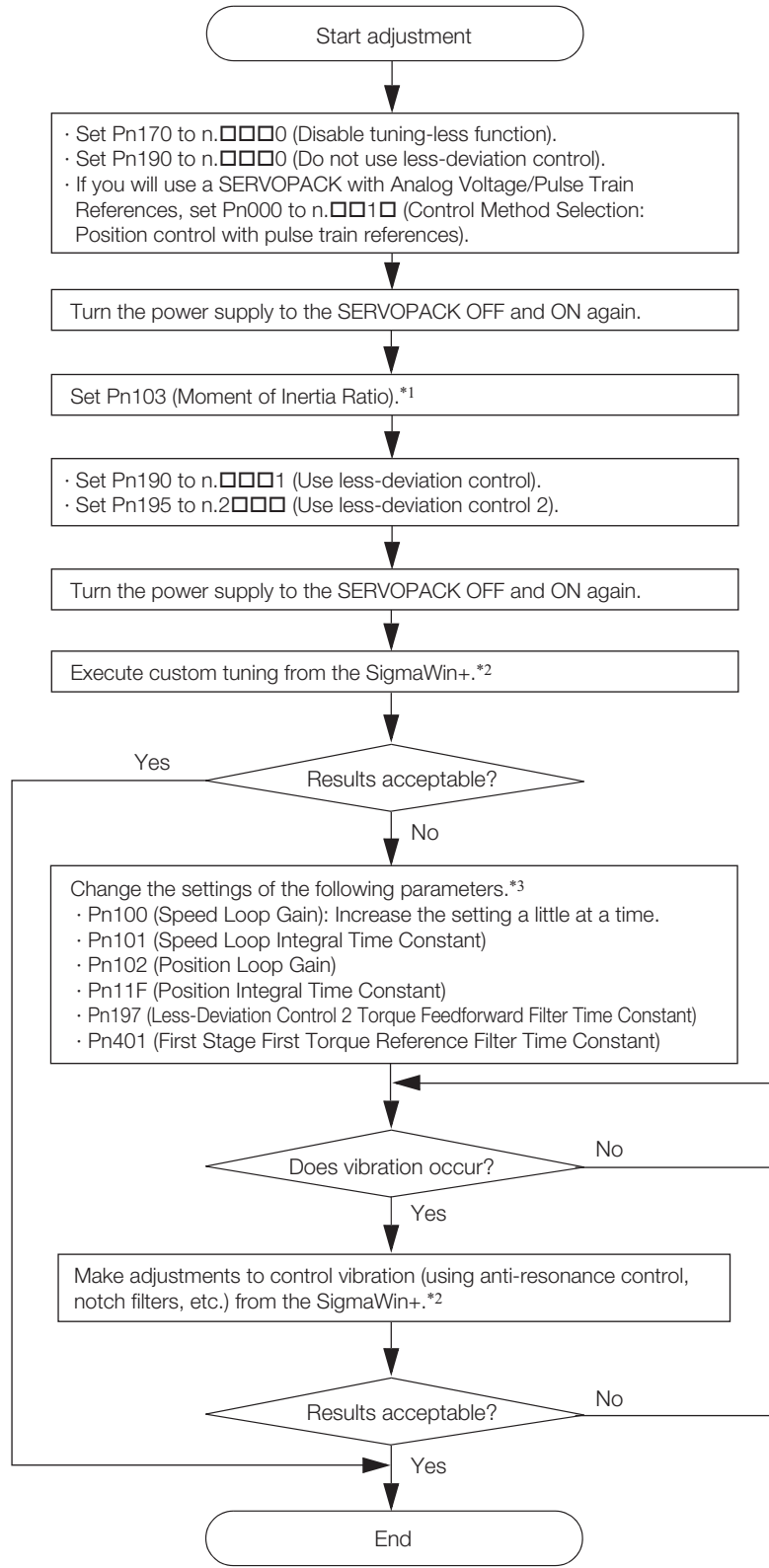
The basic adjustment flowchart for Less-Deviation Control 2 is given in the following figure. Make suitable adjustments considering the conditions and operating requirements of your machine.



- *1. Use one of the following calculation methods.
- Calculate the value manually.
 - Use the following SigmaWin+ function: Moment of Inertia Estimation.
- *2. Refer to one of the following manuals for details.
-  Σ -7-Series Σ -7S SERVOPACK with Analog Voltage/Pulse Train References Product Manual (Manual No.: SIEP S800001 26)
 -  Σ -7-Series Σ -7S SERVOPACK with MECHATROLINK-III Communications References Product Manual (Manual No.: SIEP S800001 28)
- *3. Use the following formulas as guidelines to change the settings.

$$\bullet \text{ Pn101} = \frac{2000}{2\pi \times \text{Pn100}}$$

$$\bullet \text{ Pn102} = \text{Pn100}$$

$$\bullet \text{ Pn11F} = \frac{4000}{\text{Pn102}}$$

$$\bullet \text{ Pn197} = \frac{1000}{2 \times 4 \times 2\pi \times \text{Pn100}}$$

$$\bullet \text{ Pn401} = \frac{1000}{4 \times 2\pi \times \text{Pn100}}$$

The following setting examples are for Pn100 = 40.0 Hz.

$$\bullet \text{ Pn101} = \frac{2000}{2\pi \times 40.0} \cong 7.96$$

$$\bullet \text{ Pn102} = 40.0$$

$$\bullet \text{ Pn11F} = \frac{4000}{40.0} = 100.0$$

$$\bullet \text{ Pn197} = \frac{1000}{2 \times 4 \times 2\pi \times 40.0} \cong 0.50$$

$$\bullet \text{ Pn401} = \frac{1000}{4 \times 2\pi \times 40.0} \cong 0.99$$

3.3.2 Adjustment Example

Adjustment Example for Pn100, Pn101, Pn102, Pn11F, Pn197, and Pn401

The effects of Pn100 (Speed Loop Gain), Pn101 (Speed Loop Integral Time Constant), Pn102 (Position Loop Gain), Pn11F (Position Integral Time Constant), Pn197 (Less-Deviation Control 2 Torque Feedforward Filter Time Constant), and Pn401 (First Stage First Torque Reference Filter Time Constant) are shown below.

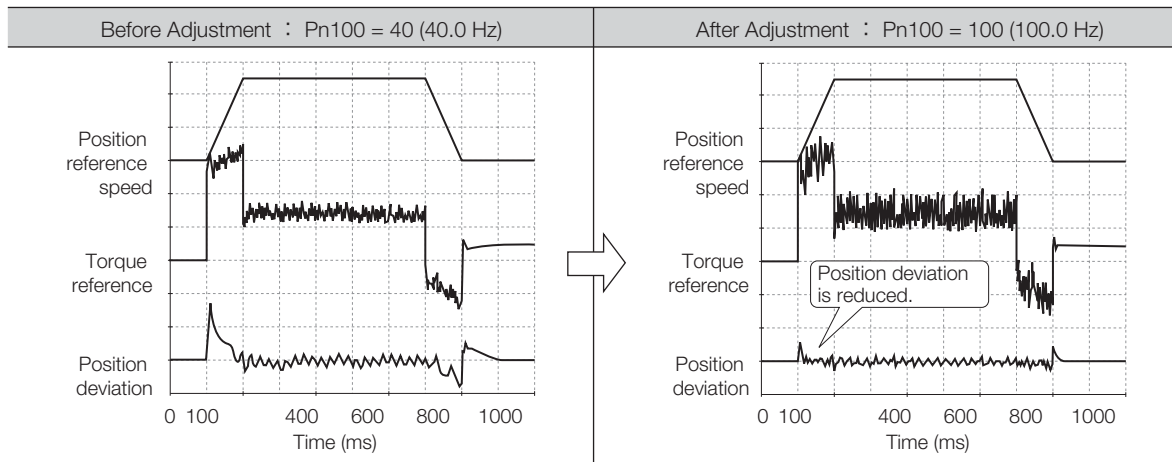

Adjustment Example for Less-Deviation Control 2 Torque Feedforward Gains (Pn198 and Pn199)

The effects of Pn198 (Less-Deviation Control 2 Forward Torque Feedforward Gain) and Pn199 (Less-Deviation Control 2 Reverse Torque Feedforward Gain) are shown below.

Torque feedforward is used for less-deviation control. The torque feedforward operation takes the differential of the input position reference, converts it to an acceleration rate, and multiplies it by the setting of Pn103 (Moment of Inertia Ratio (Mass Ratio)). Therefore, if the setting of Pn103 is smaller than the actual moment of inertia ratio (mass ratio), the effectiveness of reducing the position deviation will be diminished. On the other hand, if the setting of Pn103 is larger than the actual moment of inertia ratio (mass ratio), the position deviation can easily result in overshooting.

In this type of case, you can change the settings of Pn198 and Pn199 to effectively achieve the same things as changing Pn103 only for torque feedback.

Information It is best to correctly set Pn103 (Moment of Inertia Ratio) rather than to adjust the settings of Pn198 and Pn199. However, Pn103 will affect the entire control loop, so changing only the torque feedforward amounts (Pn198 and Pn199) after completing gain adjustment is useful for fine-tuning.

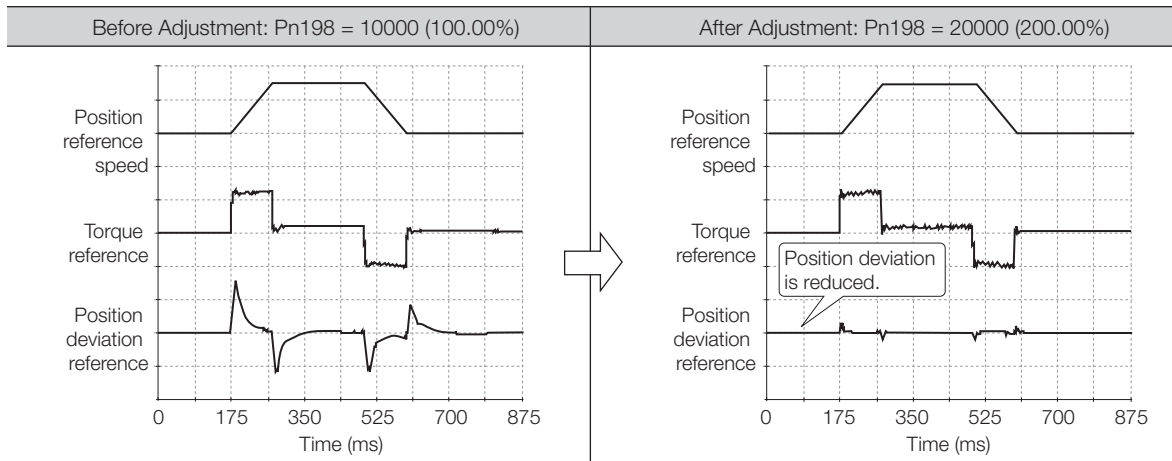

Adjustment Example for Less-Deviation Control 2 Viscous Friction Compensation Coefficients (Pn19B and Pn19D)

For mechanisms that are greatly affected by viscous friction, the effectiveness of torque feedforward (Pn198 and Pn199) is reduced. To allow for this, set one of the following parameters.

- Less-Deviation Control 2 Rotary Servomotor Viscous Friction Compensation Coefficient (Pn19B)
- Less-Deviation Control 2 Linear Servomotor Viscous Friction Compensation Coefficient (Pn19D)

By setting one of the above parameters, an equivalent viscous friction torque is added to the torque feedforward.

Set Pn19B to the percentage of the rated torque [N·m] that occurs at a motor speed of 100 min^{-1} .

The calculations for the setting of Pn19B are given below.

- 1. Operate the motor at a constant speed.**
In this procedure, $1,000 \text{ min}^{-1}$ is used.
- 2. Use a tracing operation on the SigmaWin+ or other means to measure the torque at the speed in step 1.**
Here, we will assume it was 7.5%.
- 3. Calculate the torque at 100 min^{-1} .**
 - Formula: Torque at speed in step 1 (%) $\times 100 \text{ min}^{-1} \div \text{Speed in step 1} (\text{min}^{-1})$

The calculation is as follows for this example:

- $7.5\% \times 100 \text{ min}^{-1} \div 1000 \text{ min}^{-1} = 0.75\%$

Therefore, Pn19B is set to 0.75.

The effects of Pn19B are shown below.

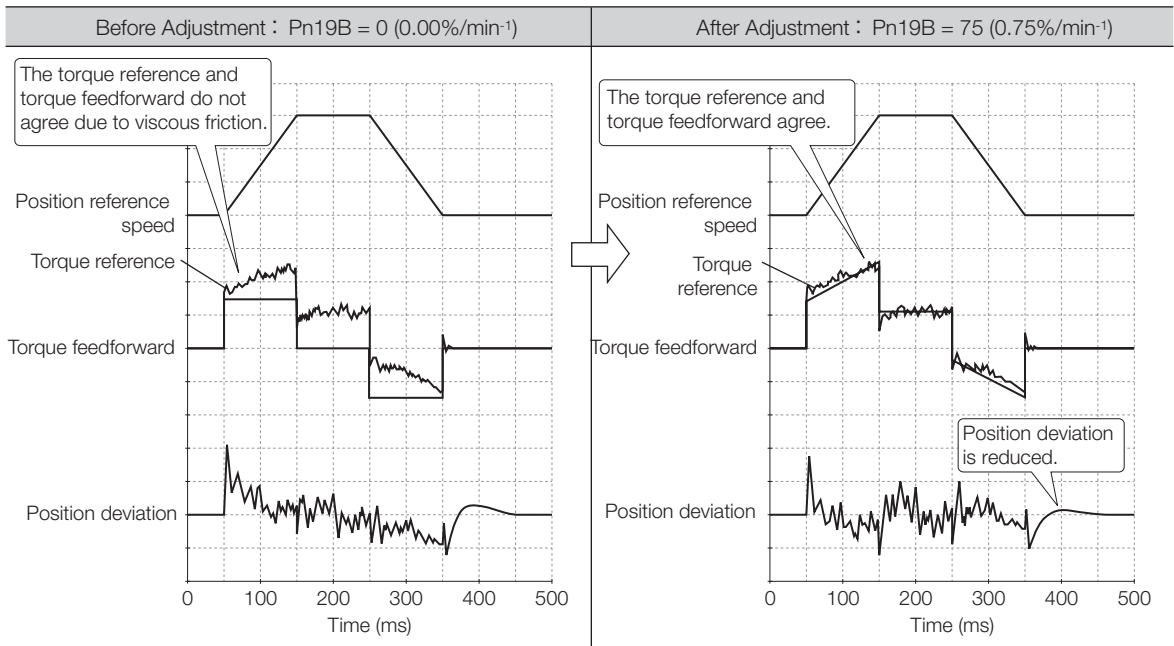

Adjustment Example for Less-Deviation Control 2 Incomplete Integration Rate (Pn19A)

With less-deviation control, the position integral is used to bring the position deviation close to 0 during constant-speed operation. However, a long period of time is normally required for the position deviation to converge to 0 with only position integration. To reduce that trend, the incomplete integral, for which the integral effect falls off with time, is also used. The default setting of Pn19A is 10,000 (100%). In other words, 100% of the previous output from integrator will be subtracted from the current input to the integrator every control cycle.

Therefore, when the deviation settles, the effectiveness of the position integral is lost. However, you can adjust this parameter to increase positioning capability when stopping if you are willing to accept a somewhat longer settling time. If you set this parameter to 0%, operation will be the same as for a normal integrator.

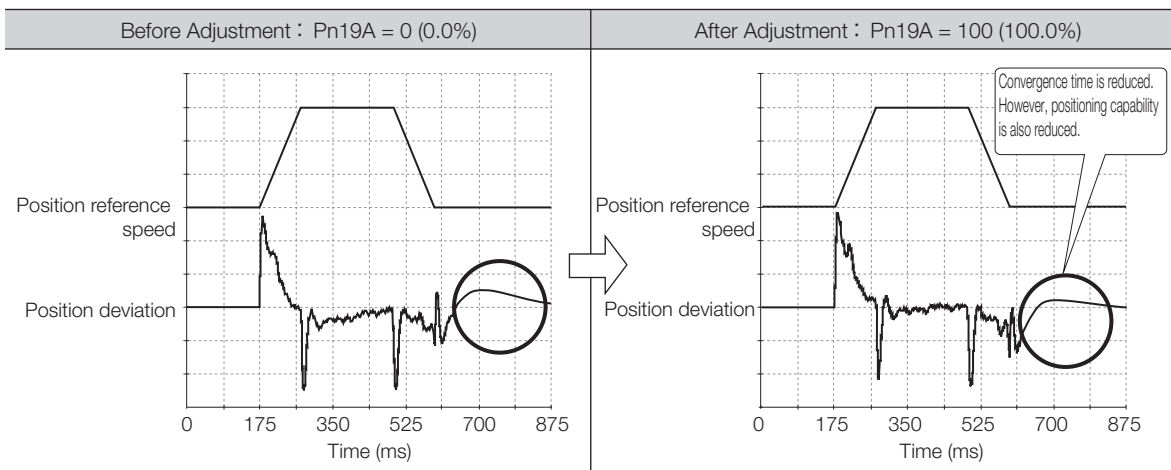

3.3.3 Gain Switching Combinations

You can use gain switching to shorten the positioning time by increasing the gains during positioning and to suppress vibration by decreasing the gains while stopping.

SERVOPACKs with Analog Voltage/Pulse Train References

| Selected Gains | Speed Loop Gain | Speed Loop Integral Time Constant | Position Loop Gain | Position Integral Time Constant | Torque Reference Filter | Friction Compensation Gain | Position Reference Acceleration/Deceleration Filter Time Constant* |
|-----------------|--------------------------------|--|-----------------------------------|---|--|---|---|
| Gain Settings 1 | Speed Loop Gain (Pn100) | Speed Loop Integral Time Constant (Pn101) | Position Loop Gain (Pn102) | Position Integral Time Constant (Pn11F) | First Stage First Torque Reference Filter Time Constant (Pn401) | Friction Compensation Gain (Pn121) | Position Reference Acceleration/Deceleration Time Constant (Pn216) |
| Gain Settings 2 | Second Speed Loop Gain (Pn104) | Second Speed Loop Integral Time Constant (Pn105) | Second Position Loop Gain (Pn106) | Less-Deviation Control 2 Second Position Integral Time Constant (Pn13F) | First Stage Second Torque Reference Filter Time Constant (Pn412) | Second Friction Compensation Gain (Pn122) | Second Position Reference Acceleration/Deceleration Time Constant (Pn234) |

* This parameter is valid only for SERVOPACKs with Analog Voltage/Pulse Train References. The gains are switched when there is no reference pulse input and reference distribution has been completed (/DEN). The timing for switching other gains and the timing for switching the Position Reference Acceleration/Deceleration Filter Time Constant are not the same.

SERVOPACKs with MECHATROLINK-III Communications References

| Selected Gains | Speed Loop Gain | Speed Loop Integral Time Constant | Position Loop Gain | Position Integral Time Constant | Torque Reference Filter | Friction Compensation Gain |
|-----------------|--------------------------------|--|-----------------------------------|---|--|---|
| Gain Settings 1 | Speed Loop Gain (Pn100) | Speed Loop Integral Time Constant (Pn101) | Position Loop Gain (Pn102) | Position Integral Time Constant (Pn11F) | First Stage First Torque Reference Filter Time Constant (Pn401) | Friction Compensation Gain (Pn121) |
| Gain Settings 2 | Second Speed Loop Gain (Pn104) | Second Speed Loop Integral Time Constant (Pn105) | Second Position Loop Gain (Pn106) | Less-Deviation Control 2 Second Position Integral Time Constant (Pn13F) | First Stage Second Torque Reference Filter Time Constant (Pn412) | Second Friction Compensation Gain (Pn122) |

3.3.4 Method to Switch the Gain

SERVOPACKs with Analog Voltage/Pulse Train References

First, make sure that Pn139 is set to n.□□□0 (manual gain switching).

To switch between gain settings 1 and gain settings 2, use the G_SEL external input signal.

| Classification | Signal Name | Connector Pin | Setting | Meaning |
|----------------|-------------|--|---------|---------------------------------------|
| Input | /G-SEL | Must be assigned with Pn50D = n.□X□□.* | OFF | Changes the gains to gain settings 1. |
| | | | ON | Changes the gains to gain settings 2. |

* Refer to the following manual for details.

📖 Σ -7-Series Σ -7S SERVOPACK with Analog Voltage/Pulse Train References Product Manual (Manual No.: SIEP S800001 26)

SERVOPACKs with MECHATROLINK-III Communications References

First, make sure that Pn139 is set to n.□□□0 (manual gain switching).

To switch between gain settings 1 and gain settings 2, use G_SEL in the servo command output signals (SVCMD_IO).

| Classification | Command Name | Setting | Meaning |
|----------------|--|---------|---------------------------------------|
| Input | G_SEL in the Servo Command Output Signals (SVCMD_IO) | 0 | Changes the gains to gain settings 1. |
| | | 1 | Changes the gains to gain settings 2. |

3.3.5 Settings for Low-speed Feeding

The tracking performance of less-deviation control is high. Therefore, if the position reference speed input is intermittent during homing or other low-speed operations, the machine may vibrate.

If that occurs, perform the following procedure.

SERVOPACKs with Analog Voltage/Pulse Train References

1. Set Pn234 (Second Position Reference Acceleration/Deceleration Time Constant) to an appropriate value.
2. During low-speed feeding, change the gains from gain settings 1 to gain settings 2. The setting of Pn234 is applied, the reference tracking performance decreases, and vibration is reduced.

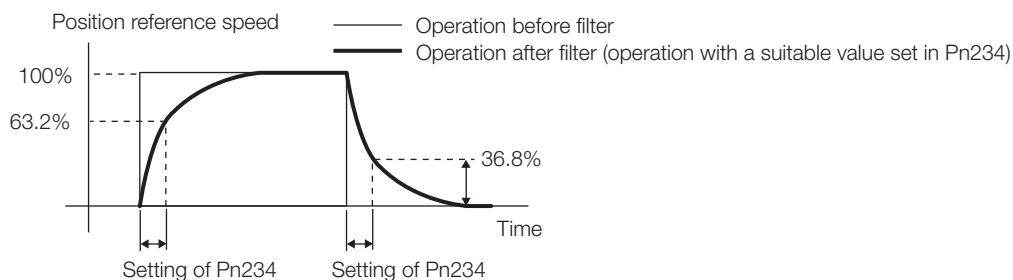



- Any change to the setting of Pn216 or Pn234 is not applied while the Servomotor is operating. Changes will be enabled the next time the Servomotor comes to a stop.
- Change the settings while there is no reference pulse input and the Servomotor is stopped.

SERVOPACKs with MECHATROLINK-III Communications References

There are the following two methods.

- Weakening reference tracking to reduce vibration
- Smoothing references to reduce vibration

◆ Weakening Reference Tracking to Reduce Vibration

During low-speed feeding, the Servo Parameter Write command (SVPRM_WR: 41h) is used to reduce the settings of the following three parameters.

- Pn196 (Less-Deviation Control 2 Speed Feedforward Gain)
- Pn198 (Less-Deviation Control 2 Forward Torque Feedforward Gain)
- Pn199 (Less-Deviation Control 2 Reverse Torque Feedforward Gain)

By reducing the settings of Pn196, Pn198, and Pn199, reference tracking is weakened to reduce vibration.

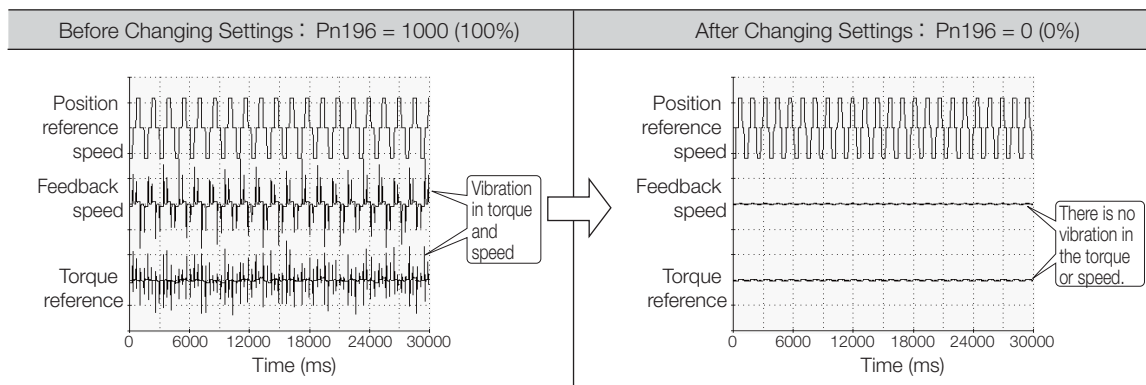

◆ Smoothing References to Reduce Vibration

During low-speed feeding, the Servo Parameter Write command (SVPRM_WR: 41h) is used to increase the settings of the following two parameters.

- Pn811 (Exponential Acceleration/Deceleration Time Constant)
- Pn812 (Movement Average Time)

By increasing the settings of Pn811 and Pn812, the reference is smoothed to reduce vibration.

3.4 Adjusting Less-Deviation Control 1

3.4.1 Adjustment Procedure

The basic adjustment flowchart for Less-Deviation Control 1 is given in the following flowchart. Make suitable adjustments considering the conditions and operating requirements of your machine.

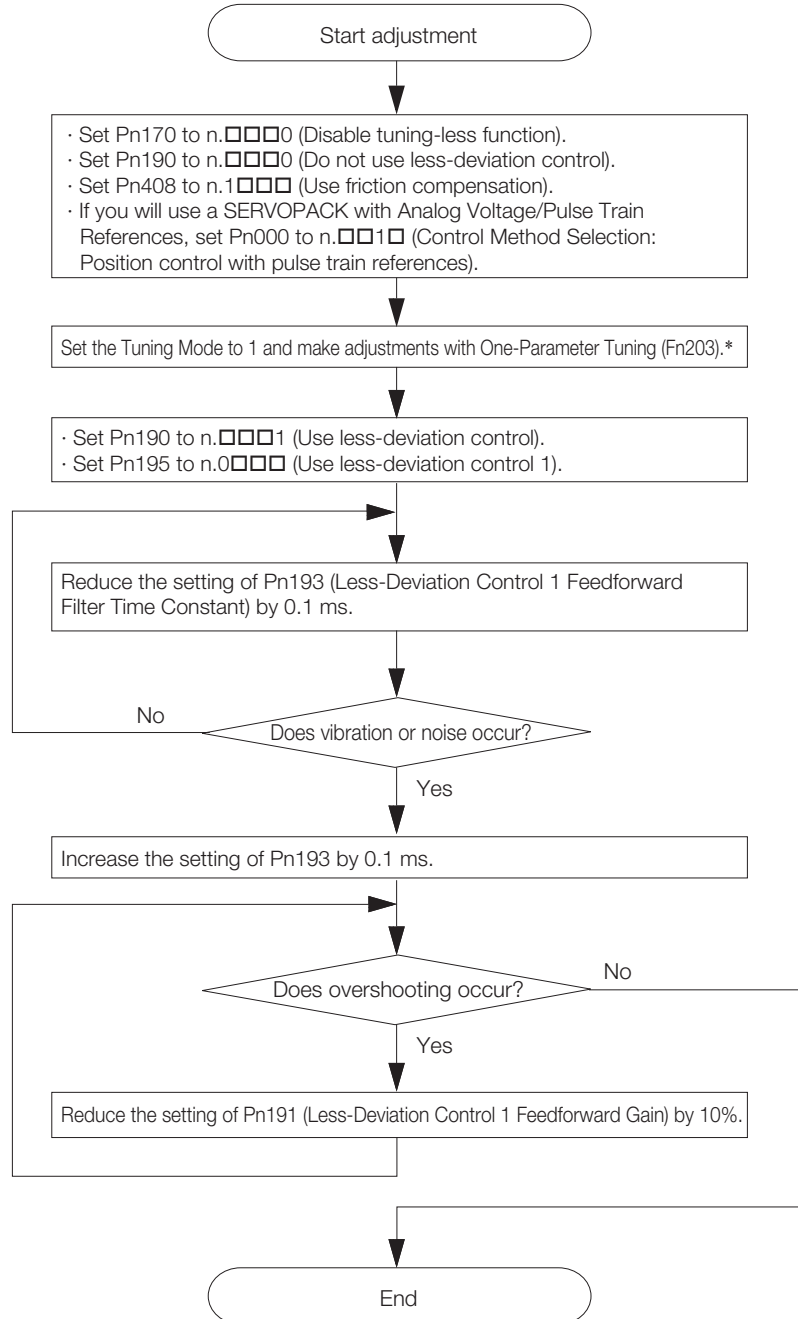

* Refer to one of the following manuals for details.

Σ-7-Series Σ-7S SERVOPACK with Analog Voltage/Pulse Train References Product Manual (Manual No.: SIEP S800001 26)

Σ-7-Series Σ-7S SERVOPACK with MECHATROLINK-III Communications References Product Manual (Manual No.: SIEP S800001 28)

3.4.2 Adjustment Example

Pn193 Adjustment Example

The effects of Pn193 (Less-Deviation Control 1 Feedforward Filter Time Constant) are shown below.

If vibration or noise occurs during operation, increase the setting of Pn193 to reduce vibration and noise. However, overshooting may increase when you do so.

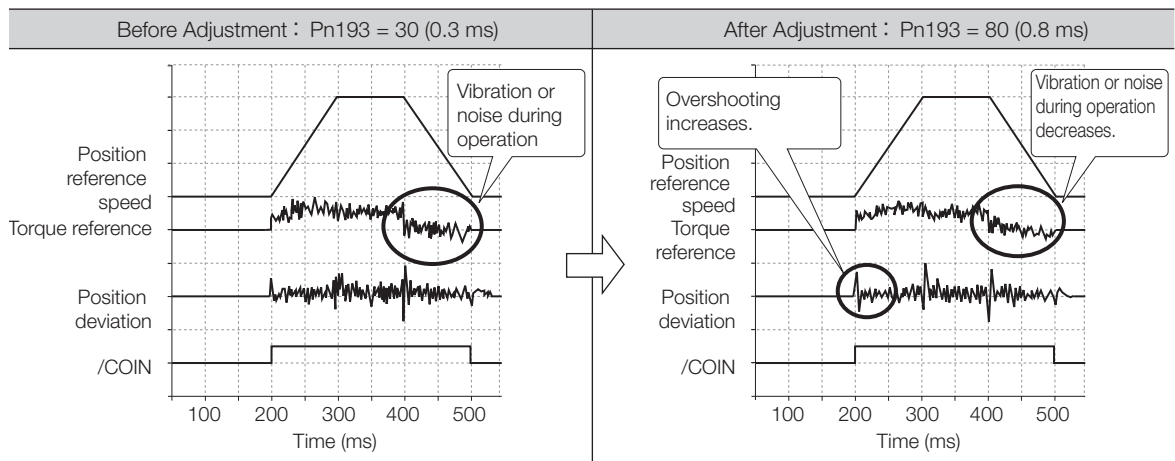

Pn191 Adjustment Example

The effects of Pn191 (Less-Deviation Control 1 Feedforward Gain) are shown below.

If the setting of Pn191 is decreased, overshooting decreases.

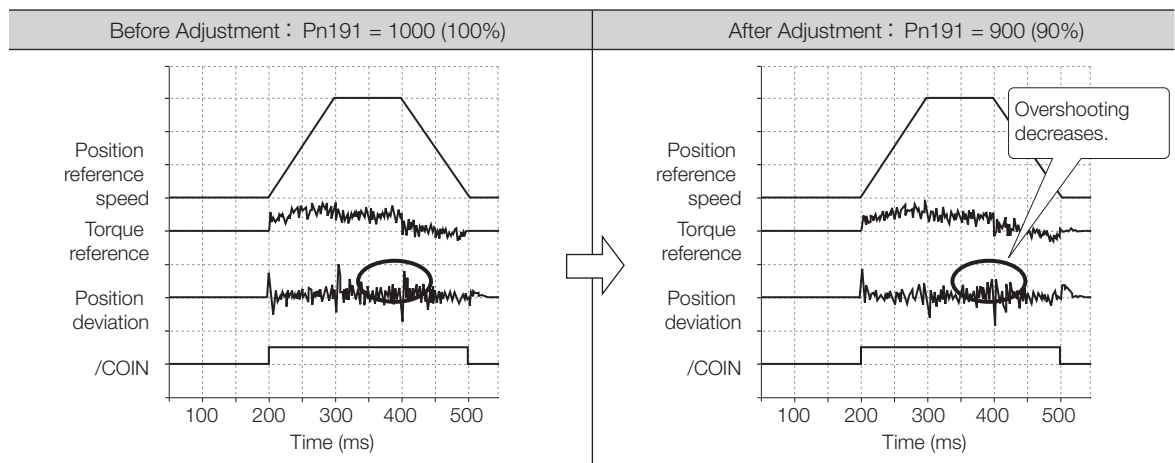

3.4.3 Gain Switching Combinations

You can use gain switching to shorten the positioning time by increasing the gains during positioning and to suppress vibration by decreasing the gains while stopping.

SERVOPACKs with Analog Voltage/Pulse Train References

| Selected Gains | Speed Loop Gain | Speed Loop Integral Time Constant | Position Loop Gain | Torque Reference Filter | Friction Compensation Gain | Position Reference Acceleration/Deceleration Filter Time Constant* | Less-Deviation Control Feedforward Gain |
|-----------------|--------------------------------|--|-----------------------------------|--|---|---|--|
| Gain Settings 1 | Speed Loop Gain (Pn100) | Speed Loop Integral Time Constant (Pn101) | Position Loop Gain (Pn102) | First Stage First Torque Reference Filter Time Constant (Pn401) | Friction Compensation Gain (Pn121) | Position Reference Acceleration/Deceleration Time Constant (Pn216) | Less-Deviation Control 1 Feedforward Gain (Pn191) |
| Gain Settings 2 | Second Speed Loop Gain (Pn104) | Second Speed Loop Integral Time Constant (Pn105) | Second Position Loop Gain (Pn106) | First Stage Second Torque Reference Filter Time Constant (Pn412) | Second Friction Compensation Gain (Pn122) | Second Position Reference Acceleration/Deceleration Time Constant (Pn234) | Less-Deviation Control 1 Second Feedforward Gain (Pn192) |

* This parameter is valid only for SERVOPACKs with Analog Voltage/Pulse Train References. The gains are switched when there is no reference pulse input and reference distribution has been completed (/DEN). The timing for switching other gains and the timing of switching the Position Reference Acceleration/Deceleration Filter Time Constant are not the same.

SERVOPACKs with MECHATROLINK-III Communications References

| Selected Gains | Speed Loop Gain | Speed Loop Integral Time Constant | Position Loop Gain | Torque Reference Filter | Friction Compensation Gain | Less-Deviation Control Feedforward Gain |
|-----------------|--------------------------------|--|-----------------------------------|--|---|--|
| Gain Settings 1 | Speed Loop Gain (Pn100) | Speed Loop Integral Time Constant (Pn101) | Position Loop Gain (Pn102) | First Stage First Torque Reference Filter Time Constant (Pn401) | Friction Compensation Gain (Pn121) | Less-Deviation Control 1 Feedforward Gain (Pn191) |
| Gain Settings 2 | Second Speed Loop Gain (Pn104) | Second Speed Loop Integral Time Constant (Pn105) | Second Position Loop Gain (Pn106) | First Stage Second Torque Reference Filter Time Constant (Pn412) | Second Friction Compensation Gain (Pn122) | Less-Deviation Control 1 Second Feedforward Gain (Pn192) |

3.4.4 Method to Switch the Gain

SERVOPACKs with Analog Voltage/Pulse Train References

First, make sure that Pn139 is set to n.□□□0 (manual gain switching).

To switch between gain settings 1 and gain settings 2, use the G_SEL external input signal.

| Classification | Signal Name | Connector Pin | Setting | Meaning |
|----------------|-------------|--|---------|---------------------------------------|
| Input | /G-SEL | Must be assigned with Pn50D = n.□X□□.* | OFF | Changes the gains to gain settings 1. |
| | | | ON | Changes the gains to gain settings 2. |

* Refer to the following manual for details.

📖 Σ -7-Series Σ -7S SERVOPACK with Analog Voltage/Pulse Train References Product Manual
(Manual No.: SIEP S800001 26)

SERVOPACKs with MECHATROLINK-III Communications References

First, make sure that Pn139 is set to n.□□□0 (manual gain switching).

To switch between gain settings 1 and gain settings 2, use G_SEL in the servo command output signals (SVCMD_IO).

| Classification | Command Name | Setting | Meaning |
|----------------|--|---------|---------------------------------------|
| Input | G_SEL in the Servo Command Output Signals (SVCMD_IO) | 0 | Changes the gains to gain settings 1. |
| | | 1 | Changes the gains to gain settings 2. |

3.4.5 Settings for Low-speed Feeding

The tracking performance of less-deviation control is high. Therefore, if the position reference speed input is intermittent during homing or other low-speed operations, the machine may vibrate.

If that occurs, perform the following procedure.

SERVOPACKs with Analog Voltage/Pulse Train References

1. Set Pn234 (Second Position Reference Acceleration/Deceleration Time Constant) to an appropriate value.
2. During low-speed feeding, change the gains from gain settings 1 to gain settings 2. The setting of Pn234 is applied, the reference tracking performance decreases, and vibration is reduced.

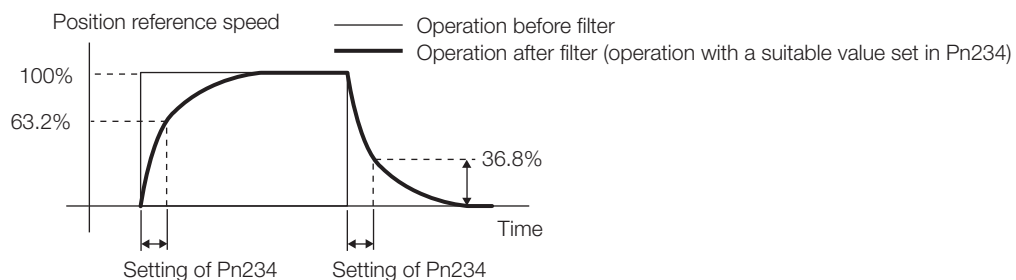



Important

- Any change to the setting of Pn216 or Pn234 is not applied while the Servomotor is operating. Changes will be enabled the next time the Servomotor comes to a stop.
- Change the settings while there is no reference pulse input and the Servomotor is stopped.

SERVOPACKs with MECHATROLINK-III Communications References

1. Set Pn192 (Less-Deviation Control 1 Second Feedforward Gain) to 0.
2. During low-speed feeding, change the gains from gain settings 1 to gain settings 2. The setting of Pn192 is applied, the reference tracking performance decreases, and vibration is reduced.

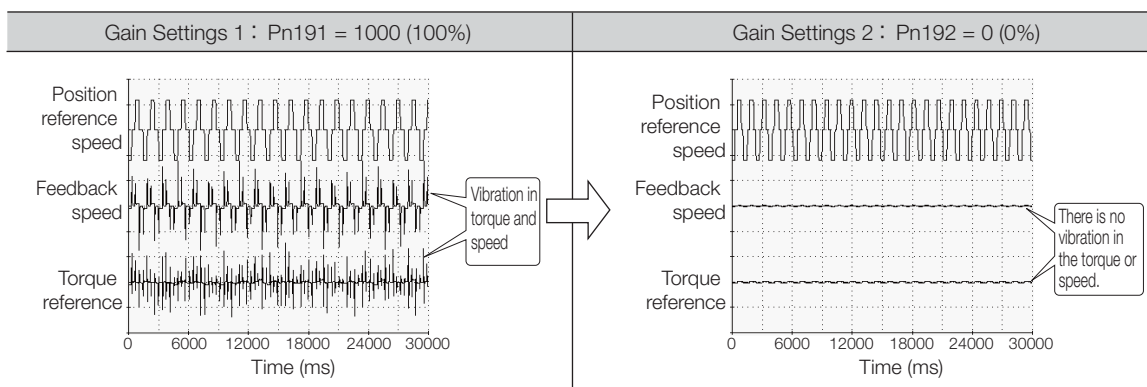

3.5 Reference Compensation

Reference compensation is used when pulse train references are input with SERVOPACKs with Analog Voltage/Pulse Train References.

If less-deviation control is enabled, reference compensation is used by the SERVOPACK to automatically divide the input references to smooth the references. Reference compensation can be used to suppress abnormal noise in motors. However, reference compensation cannot be used for an electronic gear ratio of 16/1 or less (e.g., 4/1 or 1/1).

Also, the division method for the first reference input after the SERVOPACK's control power supply is turned ON is different from the second and later reference inputs, as described below.

- First Reference Input after Control Power Supply Is Turned ON

The input reference pulses are divided by 16 and the input time is multiplied by 16.

SERVOPACK reference read cycle

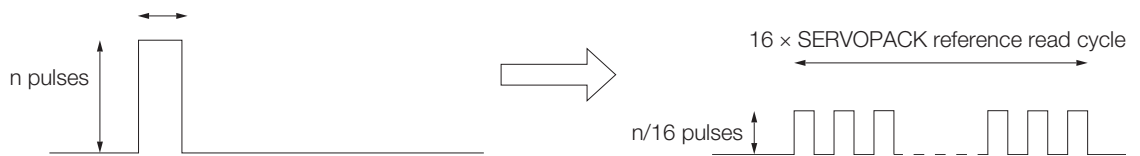

- Second or Later Reference Input after Control Power Supply Is Turned ON

The input reference pulses are divided by 16 and evenly spread over the difference between the last reference input time and this reference input time.

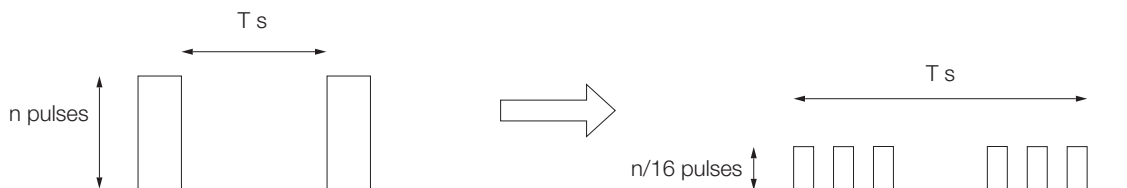

3.6 Monitoring Machine Operation Status and Signal Waveforms

To monitor waveforms, use the SigmaWin+ trace function or a measuring instrument, such as a memory recorder.

The monitoring function that is shaded in the following block diagram was added to SERVOPACKs for tracking applications.

- Monitoring the Position Deviation after the Position Reference Filter

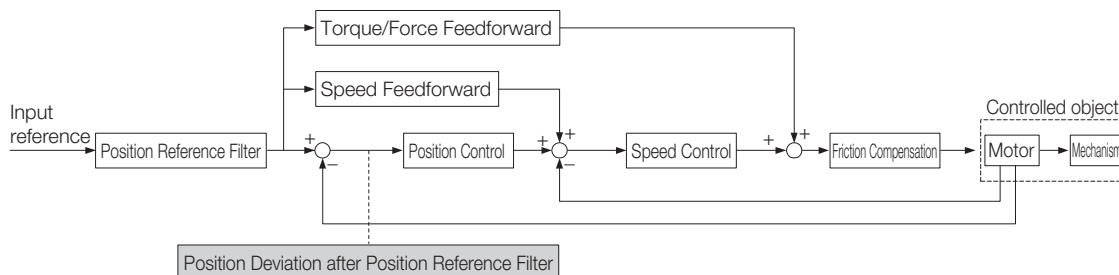

To use the SigmaWin+ to monitor the position deviation after the position reference filter, select the following signal name on the Data Tab Page in the Trace Setup Dialog Box. To display the Trace Setup Dialog Box, click the Setup Button on the Trace Dialog Box.

| Signal Name | Unit |
|--|-----------------|
| Position Deviation after Position Reference Filter | Reference units |

To use a measuring instrument to monitor the position deviation after the position reference filter, set Pn006 or Pn007 (Analog Monitor 1/2 Signal Selection) as given in the following table.

| Parameter | Description | | |
|----------------|--|-----------------------|---------|
| | Monitor Signal | Output Unit | Remarks |
| Pn006 Pn007 | n.□□25 Position Deviation after Position Reference Filter | 0.05 V/Reference unit | - |

Refer to one of the following manuals for details on the monitor items other than the position deviation after the position reference filter.

📖 Σ -7-Series Σ -7S SERVOPACK with Analog Voltage/Pulse Train References Product Manual (Manual No.: SIEP S800001 26)

📖 Σ -7-Series Σ -7S SERVOPACK with MECHATROLINK-III Communications References Product Manual (Manual No.: SIEP S800001 28)

Maintenance

4

This chapter provides information on the meaning of, causes of, and corrections for alarms and warnings.

4.1 SERVOPACKs with Analog Voltage/Pulse Train References . . 4-2

- 4.1.1 Alarm Displays 4-2
- 4.1.2 List of Alarms 4-2
- 4.1.3 Troubleshooting Alarms 4-9
- 4.1.4 Warning Displays 4-38
- 4.1.5 List of Warnings 4-39
- 4.1.6 Troubleshooting Warnings 4-40
- 4.1.7 Troubleshooting Based on the Operation
and Conditions of the Servomotor 4-46

4.2 SERVOPACKs with MECHATROLINK-III Communications References . . 4-58

- 4.2.1 Alarm Displays 4-58
- 4.2.2 List of Alarms 4-58
- 4.2.3 Troubleshooting Alarms 4-64
- 4.2.4 Warning Displays 4-95
- 4.2.5 List of Warnings 4-96
- 4.2.6 Troubleshooting Warnings 4-98
- 4.2.7 Troubleshooting Based on the Operation
and Conditions of the Servomotor 4-105

4.1 SERVOPACKs with Analog Voltage/Pulse Train References

4.1.1 Alarm Displays

If an error occurs in the SERVOPACK, an alarm number will be displayed on the panel display. However, if only “-” appears on the panel display, this indicates a SERVOPACK system error. Replace the SERVOPACK.

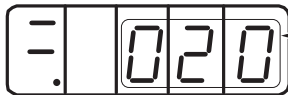

Example: If an A.020 alarm occurs, “020” will flash on the display.

4.1.2 List of Alarms

The list of alarms gives the alarm name, alarm meaning, alarm stopping method, alarm reset possibility, and alarm code output in order of the alarm numbers.

Servomotor Stopping Method for Alarms

Refer to the following manual for information on the stopping method for alarms.

📖 Σ -7-Series Σ -7S SERVOPACK with Analog Voltage/Pulse Train References Product Manual (Manual No.: SIEP S800001 26)

Alarm Reset Possibility

Yes: You can use an alarm reset to clear the alarm. However, this assumes that the cause of the alarm has been removed.

No: You cannot clear the alarm.

List of Alarms

| Alarm Number | Alarm Name | Alarm Meaning | Servo-motor Stopping Method | Alarm Reset Possi-ble? | Alarm Code Output | | |
|--------------|-----------------------------|--|-----------------------------|------------------------|-------------------|------|------|
| | | | | | ALO1 | ALO2 | ALO3 |
| A.020 | Parameter Checksum Error | There is an error in the parameter data in the SERVOPACK. | Gr.1 | No | H | H | H |
| A.021 | Parameter Format Error | There is an error in the parameter data format in the SERVOPACK. | Gr.1 | No | H | H | H |
| A.022 | System Checksum Error | There is an error in the parameter data in the SERVOPACK. | Gr.1 | No | H | H | H |
| A.024 | System Alarm | An internal program error occurred in the SERVOPACK. | Gr.1 | No | H | H | H |
| A.025 | System Alarm | An internal program error occurred in the SERVOPACK. | Gr.1 | No | H | H | H |
| A.030 | Main Circuit Detector Error | There is an error in the detection data for the main circuit. | Gr.1 | Yes | H | H | H |
| A.040 | Parameter Setting Error | A parameter setting is outside of the setting range. | Gr.1 | No | H | H | H |

Continued on next page.

Continued from previous page.

| Alarm Number | Alarm Name | Alarm Meaning | Servo-motor Stopping Method | Alarm Reset Possible? | Alarm Code Output | | |
|--------------|---|---|-----------------------------|-----------------------|-------------------|------|------|
| | | | | | AL01 | AL02 | AL03 |
| A.041 | Encoder Output Pulse Setting Error | The setting of Pn212 (Number of Encoder Output Pulses) or Pn281 (Encoder Output Resolution) is outside of the setting range or does not satisfy the setting conditions. | Gr.1 | No | H | H | H |
| A.042 | Parameter Combination Error | The combination of some parameters exceeds the setting range. | Gr.1 | No | H | H | H |
| A.044 | Semi-Closed/Fully-Closed Loop Control Parameter Setting Error | The settings of the Option Module and Pn002 = n.X□□□ (External Encoder Usage) do not match. | Gr.1 | No | H | H | H |
| A.050 | Combination Error | The capacities of the SERVOPACK and Servomotor do not match. | Gr.1 | Yes | H | H | H |
| A.051 | Unsupported Device Alarm | An unsupported device was connected. | Gr.1 | No | H | H | H |
| A.070 | Motor Type Change Detected | The connected motor is a different type of motor from the previously connected motor. | Gr.1 | No | H | H | H |
| A.080 | Linear Encoder Pitch Setting Error | The setting of Pn282 (Linear Encoder Scale Pitch) has not been changed from the default setting. | Gr.1 | No | H | H | H |
| A.0b0 | Invalid Servo ON Command Alarm | The /S-ON (Servo ON) signal was input from the host controller after a utility function that turns ON the Servomotor was executed. | Gr.1 | Yes | H | H | H |
| A.100 | Overcurrent Detected | An overcurrent flowed through the power transistor or the heat sink overheated. | Gr.1 | No | L | H | H |
| A.101 | Motor Overcurrent Detected | The current to the motor exceeded the allowable current. | Gr.1 | No | L | H | H |
| A.300 | Regeneration Error | There is an error related to regeneration. | Gr.1 | Yes | L | L | H |
| A.320 | Regenerative Overload | A regenerative overload occurred. | Gr.2 | Yes | L | L | H |
| A.330 | Main Circuit Power Supply Wiring Error | <ul style="list-style-type: none"> The AC power supply input setting or DC power supply input setting is not correct. The power supply wiring is not correct. | Gr.1 | Yes | L | L | H |
| A.400 | Overvoltage | The main circuit DC voltage is too high. | Gr.1 | Yes | H | H | L |
| A.410 | Undervoltage | The main circuit DC voltage is too low. | Gr.2 | Yes | H | H | L |
| A.510 | Overspeed | The motor exceeded the maximum speed. | Gr.1 | Yes | L | H | L |

Continued on next page.

4.1 SERVOPACKs with Analog Voltage/Pulse Train References

4.1.2 List of Alarms

Continued from previous page.

| Alarm Number | Alarm Name | Alarm Meaning | Servo-motor Stopping Method | Alarm Reset Possible? | Alarm Code Output | | |
|--------------|--|---|-----------------------------|-----------------------|-------------------|------|------|
| | | | | | ALO1 | ALO2 | ALO3 |
| A.511 | Encoder Output Pulse Overspeed | <ul style="list-style-type: none"> Rotary Servomotor: The pulse output speed for the setting of Pn212 (Number of Encoder Output Pulses) was exceeded. Linear Servomotor: The motor speed upper limit for the setting of Pn281 (Encoder Output Resolution) was exceeded. | Gr.1 | Yes | L | H | L |
| A.520 | Vibration Alarm | Abnormal oscillation was detected in the motor speed. | Gr.1 | Yes | L | H | L |
| A.521 | Autotuning Alarm | Vibration was detected during autotuning for the tuning-less function. | Gr.1 | Yes | L | H | L |
| A.550 | Maximum Speed Setting Error | The setting of Pn385 (Maximum Motor Speed) is greater than the maximum motor speed. | Gr.1 | Yes | L | H | L |
| A.710 | Instantaneous Overload | The Servomotor was operating for several seconds to several tens of seconds under a torque that largely exceeded the rating. | Gr.2 | Yes | L | L | L |
| A.720 | Continuous Overload | The Servomotor was operating continuously under a torque that exceeded the rating. | Gr.1 | Yes | L | L | L |
| A.730 | Dynamic Brake Overload | When the dynamic brake was applied, the rotational or linear kinetic energy exceeded the capacity of the dynamic brake resistor. | Gr.1 | Yes | L | L | L |
| A.731 | | | | | | | |
| A.740 | Inrush Current Limiting Resistor Overload | The main circuit power supply was frequently turned ON and OFF. | Gr.1 | Yes | L | L | L |
| A.7A1 | Internal Temperature Error 1 (Control Board Temperature Error) | The surrounding temperature of the control PCB is abnormal. | Gr.2 | Yes | L | L | L |
| A.7A2 | Internal Temperature Error 2 (Power Board Temperature Error) | The surrounding temperature of the power PCB is abnormal. | Gr.2 | Yes | L | L | L |
| A.7A3 | Internal Temperature Sensor Error | An error occurred in the temperature sensor circuit. | Gr.2 | No | L | L | L |
| A.7Ab | SERVOPACK Built-in Fan Stopped | The fan inside the SERVOPACK stopped. | Gr.1 | Yes | L | L | L |
| A.810 | Encoder Backup Alarm | The power supplies to the encoder all failed and the position data was lost. | Gr.1 | No | H | H | H |
| A.820 | Encoder Checksum Alarm | There is an error in the checksum results for encoder memory. | Gr.1 | No | H | H | H |
| A.830 | Encoder Battery Alarm | The battery voltage was lower than the specified level after the control power supply was turned ON. | Gr.1 | Yes | H | H | H |

Continued on next page.

Continued from previous page.

| Alarm Number | Alarm Name | Alarm Meaning | Servo-motor Stopping Method | Alarm Reset Possible? | Alarm Code Output | | |
|--------------|---|---|-----------------------------|-----------------------|-------------------|------|------|
| | | | | | ALO1 | ALO2 | ALO3 |
| A.840 | Encoder Data Alarm | There is an internal data error in the encoder. | Gr.1 | No | H | H | H |
| A.850 | Encoder Overspeed | The encoder was operating at high speed when the power was turned ON. | Gr.1 | No | H | H | H |
| A.860 | Encoder Overheated | The internal temperature of the rotary encoder or linear encoder is too high. | Gr.1 | No | H | H | H |
| A.861 | Motor Overheated | The internal temperature of motor is too high. | Gr.1 | No | H | H | H |
| A.862 | Overheat Alarm | The input voltage (temperature) for the overheat protection input (TH) signal exceeded the setting of Pn61B (Overheat Alarm Level). | Gr.1 | Yes | H | H | H |
| A.890 | Encoder Scale Error | A failure occurred in the linear encoder. | Gr.1 | No | H | H | H |
| A.891 | Encoder Module Error | An error occurred in the linear encoder. | Gr.1 | No | H | H | H |
| A.8A0 | External Encoder Error | An error occurred in the external encoder. | Gr.1 | Yes | H | H | H |
| A.8A1 | External Encoder Module Error | An error occurred in the Serial Converter Unit. | Gr.1 | Yes | H | H | H |
| A.8A2 | External Incremental Encoder Sensor Error | An error occurred in the external encoder. | Gr.1 | Yes | H | H | H |
| A.8A3 | External Absolute Encoder Position Error | An error occurred in the position data of the external encoder. | Gr.1 | Yes | H | H | H |
| A.8A5 | External Encoder Overspeed | An overspeed error occurred in the external encoder. | Gr.1 | Yes | H | H | H |
| A.8A6 | External Encoder Overheated | An overheating error occurred in the external encoder. | Gr.1 | Yes | H | H | H |
| A.b10 | Speed Reference A/D Error | An error occurred in the A/D converter for the speed reference input. | Gr.2 | Yes | H | H | H |
| A.b11 | Speed Reference A/D Data Error | An error occurred in the A/D conversion data for the speed reference. | Gr.2 | Yes | H | H | H |
| A.b20 | Torque Reference A/D Error | An error occurred in the A/D converter for the torque reference input. | Gr.2 | Yes | H | H | H |
| A.b33 | Current Detection Error 3 | An error occurred in the current detection circuit. | Gr.1 | No | H | H | H |
| A.bF0 | System Alarm 0 | Internal program error 0 occurred in the SERVOPACK. | Gr.1 | No | H | H | H |
| A.bF1 | System Alarm 1 | Internal program error 1 occurred in the SERVOPACK. | Gr.1 | No | H | H | H |
| A.bF2 | System Alarm 2 | Internal program error 2 occurred in the SERVOPACK. | Gr.1 | No | H | H | H |

Continued on next page.

4.1 SERVOPACKs with Analog Voltage/Pulse Train References

4.1.2 List of Alarms

Continued from previous page.

| Alarm Number | Alarm Name | Alarm Meaning | Servo-motor Stopping Method | Alarm Reset Possible? | Alarm Code Output | | |
|--------------|--|---|-----------------------------|-----------------------|-------------------|------|------|
| | | | | | ALO1 | ALO2 | ALO3 |
| A.bF3 | System Alarm 3 | Internal program error 3 occurred in the SERVO-PACK. | Gr.1 | No | H | H | H |
| A.bF4 | System Alarm 4 | Internal program error 4 occurred in the SERVO-PACK. | Gr.1 | No | H | H | H |
| A.bF5 | System Alarm 5 | Internal program error 5 occurred in the SERVO-PACK. | Gr.1 | No | H | H | H |
| A.bF6 | System Alarm 6 | Internal program error 6 occurred in the SERVO-PACK. | Gr.1 | No | H | H | H |
| A.bF7 | System Alarm 7 | Internal program error 7 occurred in the SERVO-PACK. | Gr.1 | No | H | H | H |
| A.bF8 | System Alarm 8 | Internal program error 8 occurred in the SERVO-PACK. | Gr.1 | No | H | H | H |
| A.C10 | Servomotor Out of Control | The Servomotor ran out of control. | Gr.1 | Yes | L | H | L |
| A.C20 | Phase Detection Error | The detection of the phase is not correct. | Gr.1 | No | L | H | L |
| A.C21 | Polarity Sensor Error | An error occurred in the polarity sensor. | Gr.1 | No | L | H | L |
| A.C22 | Phase Information Disagreement | The phase information does not match. | Gr.1 | No | L | H | L |
| A.C50 | Polarity Detection Failure | The polarity detection failed. | Gr.1 | No | L | H | L |
| A.C51 | Overtravel Detected during Polarity Detection | The overtravel signal was detected during polarity detection. | Gr.1 | Yes | L | H | L |
| A.C52 | Polarity Detection Not Completed | The servo was turned ON before the polarity was detected. | Gr.1 | Yes | L | H | L |
| A.C53 | Out of Range of Motion for Polarity Detection | The travel distance exceeded the setting of Pn48E (Polarity Detection Range). | Gr.1 | No | L | H | L |
| A.C54 | Polarity Detection Failure 2 | The polarity detection failed. | Gr.1 | No | L | H | L |
| A.C80 | Encoder Clear Error or Multiturn Limit Setting Error | The multiturn data for the absolute encoder was not correctly cleared or set. | Gr.1 | No | L | H | L |
| A.C90 | Encoder Communications Error | Communications between the encoder and SERVO-PACK is not possible. | Gr.1 | No | L | H | L |
| A.C91 | Encoder Communications Position Data Acceleration Rate Error | An error occurred in calculating the position data of the encoder. | Gr.1 | No | L | H | L |
| A.C92 | Encoder Communications Timer Error | An error occurred in the communications timer between the encoder and SERVO-PACK. | Gr.1 | No | L | H | L |
| A.CA0 | Encoder Parameter Error | The parameters in the encoder are corrupted. | Gr.1 | No | L | H | L |

Continued on next page.

Continued from previous page.

| Alarm Number | Alarm Name | Alarm Meaning | Servo-motor Stopping Method | Alarm Reset Possible? | Alarm Code Output | | |
|--------------|---|---|-----------------------------|-----------------------|-------------------|------|------|
| | | | | | AL01 | AL02 | AL03 |
| A.Cb0 | Encoder Echoback Error | The contents of communications with the encoder are incorrect. | Gr.1 | No | L | H | L |
| A.CC0 | Multiturn Limit Disagreement | Different multiturn limits have been set in the encoder and the SERVOPACK. | Gr.1 | No | L | H | L |
| A.CF1 | Reception Failed Error in Feedback Option Module Communications | Receiving data from the Feedback Option Module failed. | Gr.1 | No | L | H | L |
| A.CF2 | Timer Stopped Error in Feedback Option Module Communications | An error occurred in the timer for communications with the Feedback Option Module. | Gr.1 | No | L | H | L |
| A.d00 | Position Deviation Overflow | The setting of Pn520 (Position Deviation Overflow Alarm Level) was exceeded by the position deviation while the servo was ON. | Gr.1 | Yes | L | L | H |
| A.d01 | Position Deviation Overflow Alarm at Servo ON | The servo was turned ON after the position deviation exceeded the setting of Pn526 (Position Deviation Overflow Alarm Level at Servo ON) while the servo was OFF. | Gr.1 | Yes | L | L | H |
| A.d02 | Position Deviation Overflow Alarm for Speed Limit at Servo ON | If position deviation remains in the deviation counter, the setting of Pn529 or Pn584 (Speed Limit Level at Servo ON) limits the speed when the servo is turned ON. This alarm occurs if reference pulses are input and the setting of Pn520 (Position Deviation Overflow Alarm Level) is exceeded before the limit is cleared. | Gr.2 | Yes | L | L | H |
| A.d10 | Motor-Load Position Deviation Overflow | There was too much position deviation between the motor and load during fully-closed loop control. | Gr.2 | Yes | L | L | H |
| A.d30 | Position Data Overflow | The position feedback data exceeded $\pm 1,879,048,192$. | Gr.1 | No | L | L | H |
| A.E71 | Safety Option Module Detection Failure | Detection of the Safety Option Module failed. | Gr.1 | No | H | L | L |
| A.E72 | Feedback Option Module Detection Failure | Detection of the Feedback Option Module failed. | Gr.1 | No | H | L | L |
| A.E74 | Unsupported Safety Option Module | An unsupported Safety Option Module was connected. | Gr.1 | No | H | L | L |
| A.Eb1 | Safety Function Signal Input Timing Error | An error occurred in the input timing of the safety function signal. | Gr.1 | No | H | L | L |
| A.EC8 | Gate Drive Error 1 | An error occurred in the gate drive circuit. | Gr.1 | No | H | L | L |
| A.EC9 | Gate Drive Error 2 | An error occurred in the gate drive circuit. | Gr.1 | No | H | L | L |

Continued on next page.

4.1 SERVOPACKs with Analog Voltage/Pulse Train References

4.1.2 List of Alarms

Continued from previous page.

| Alarm Number | Alarm Name | Alarm Meaning | Servo-motor Stopping Method | Alarm Reset Possible? | Alarm Code Output | | |
|--------------|---|--|-----------------------------|-----------------------|-------------------|------|------|
| | | | | | ALO1 | ALO2 | ALO3 |
| A.F10 | Power Supply Line Open Phase | The voltage was low for more than one second for phase R, S, or T when the main power supply was ON. | Gr.2 | Yes | H | L | H |
| FL-1* | System Alarm | An internal program error occurred in the SERVO-PACK. | - | No | Undefined. | | |
| FL-2* | | | | | | | |
| FL-3* | | | | | | | |
| FL-4* | | | | | | | |
| FL-5* | | | | | | | |
| FL-6* | | | | | | | |
| CPF00 | Digital Operator Communications Error 1 | Communications were not possible between the Digital Operator (model: JUSP-OP05A-1-E) and the SERVO-PACK (e.g., a CPU error occurred). | - | No | Undefined. | | |
| CPF01 | Digital Operator Communications Error 2 | | | | | | |

* These alarms are not stored in the alarm history. They are only displayed on the panel display.

Note: The A.Eb0, A.Eb2 to A.Eb9, and A.EC0 to A.EC2 alarms can occur when a Safety Module is connected. Refer to the following manual for details.

 AC Servo Drive Σ -V-Series/ Σ -V-Series for Large-Capacity Models/ Σ -7-Series User's Manual Safety Module (Manual No.: SIEP C720829 06)

4.1.3 Troubleshooting Alarms

The causes of and corrections for the alarms are given in the following table. Contact your Yaskawa representative if you cannot solve a problem with the correction given in the table.

| Alarm Number: Alarm Name | Possible Cause | Confirmation | Correction | Reference |
|---|--|---|--|-----------|
| A.020: Parameter Checksum Error (There is an error in the parameter data in the SER- VOPACK.) | The power supply voltage suddenly dropped. | Measure the power supply voltage. | Set the power supply voltage within the specified range, and initialize the parameter settings. | *1 |
| | The power supply was shut OFF while writing parameter settings. | Check the timing of shutting OFF the power supply. | Initialize the parameter settings and then set the parameters again. | *1 |
| | The number of times that parameters were written exceeded the limit. | Check to see if the parameters were frequently changed from the host controller. | The SERVOPACK may be faulty. Replace the SERVOPACK. Reconsider the method for writing the parameters. | – |
| | A malfunction was caused by noise from the AC power supply, ground, static electricity, or other source. | Turn the power supply to the SERVOPACK OFF and ON again. If the alarm still occurs, noise may be the cause. | Implement countermeasures against noise. | *1 |
| | Gas, water drops, or cutting oil entered the SERVOPACK and caused failure of the internal components. | Check the installation conditions. | The SERVOPACK may be faulty. Replace the SERVOPACK. | – |
| | A failure occurred in the SERVOPACK. | Turn the power supply to the SERVOPACK OFF and ON again. If the alarm still occurs, the SERVOPACK may have failed. | The SERVOPACK may be faulty. Replace the SERVOPACK. | – |
| A.021: Parameter Format Error (There is an error in the parameter data format in the SERVOPACK.) | The software version of the SERVOPACK that caused the alarm is older than the software version of the parameters specified to write. | Read the product information to see if the software versions are the same. If they are different, it could be the cause of the alarm. | Write the parameters from another SERVOPACK with the same model and the same software version, and then turn the power OFF and ON again. | *1 |
| | A failure occurred in the SERVOPACK. | – | The SERVOPACK may be faulty. Replace the SERVOPACK. | – |
| A.022: System Checksum Error (There is an error in the parameter data in the SERVOPACK.) | The power supply voltage suddenly dropped. | Measure the power supply voltage. | The SERVOPACK may be faulty. Replace the SERVOPACK. | – |
| | The power supply was shut OFF while setting a utility function. | Check the timing of shutting OFF the power supply. | The SERVOPACK may be faulty. Replace the SERVOPACK. | – |
| | A failure occurred in the SERVOPACK. | Turn the power supply to the SERVOPACK OFF and ON again. If the alarm still occurs, the SERVOPACK may have failed. | The SERVOPACK may be faulty. Replace the SERVOPACK. | – |

Continued on next page.

4.1 SERVOPACKs with Analog Voltage/Pulse Train References

4.1.3 Troubleshooting Alarms

Continued from previous page.

| Alarm Number: Alarm Name | Possible Cause | Confirmation | Correction | Reference |
|--|---|---|--|-----------|
| A.024: System Alarm (An internal program error occurred in the SERVOPACK.) | A failure occurred in the SERVOPACK. | – | The SERVOPACK may be faulty. Replace the SERVOPACK. | – |
| A.025: System Alarm (An internal program error occurred in the SERVOPACK.) | A failure occurred in the SERVOPACK. | – | The SERVOPACK may be faulty. Replace the SERVOPACK. | – |
| A.030: Main Circuit Detector Error | A failure occurred in the SERVOPACK. | – | The SERVOPACK may be faulty. Replace the SERVOPACK. | – |
| A.040: Parameter Setting Error (A parameter setting is outside of the setting range.) | The SERVOPACK and Servomotor capacities do not match each other. | Check the combination of the SERVOPACK and Servomotor capacities. | Select a proper combination of SERVOPACK and Servomotor capacities. | *1 |
| | The motor parameter file was not written to the linear encoder. (This applies only when not using a Serial Converter Unit.) | Check to see if the motor parameter file was written to the linear encoder. | Write the motor parameter file to the linear encoder. | *1 |
| | A failure occurred in the SERVOPACK. | – | The SERVOPACK may be faulty. Replace the SERVOPACK. | – |
| | A parameter setting is outside of the setting range. | Check the setting ranges of the parameters that have been changed. | Set the parameters to values within the setting ranges. | – |
| | The electronic gear ratio is outside of the setting range. | Check the electronic gear ratio. The ratio must be within the following range: $0.001 < (Pn20E/Pn210) < 64,000$. | Set the electronic gear ratio in the following range: $0.001 < (Pn20E/Pn210) < 64,000$. | *1 |
| A.041: Encoder Output Pulse Setting Error | The setting of Pn212 (Number of Encoder Output Pulses) or Pn281 (Encoder Output Resolution) is outside of the setting range or does not satisfy the setting conditions. | Check the setting of Pn212 or Pn281. | Set Pn212 or Pn281 to an appropriate value. | *1 |

Continued on next page.

Continued from previous page.

| Alarm Number: Alarm Name | Possible Cause | Confirmation | Correction | Reference |
|--|--|--|--|-----------|
| A.042: Parameter Combination Error | The speed of program jogging went below the setting range when the electronic gear ratio (Pn20E/Pn210) or the Servomotor was changed. | Check to see if the detection conditions* ² are satisfied. | Decrease the setting of the electronic gear ratio (Pn20E/Pn210). | *1 |
| | The speed of program jogging went below the setting range when Pn533 or Pn585 (Program Jogging Movement Speed) was changed. | Check to see if the detection conditions* ² are satisfied. | Increase the setting of Pn533 or Pn585. | *1 |
| | The movement speed of advanced autotuning went below the setting range when the electronic gear ratio (Pn20E/Pn210) or the Servomotor was changed. | Check to see if the detection conditions* ³ are satisfied. | Decrease the setting of the electronic gear ratio (Pn20E/Pn210). | *1 |
| A.044: Semi-Closed/ Fully-Closed Loop Control Parameter Setting Error | The setting of the Fully-closed Module does not match the setting of Pn002 = n.X□□□ (External Encoder Usage). | Check the setting of Pn002 = n.X□□□. | Make sure that the setting of the Fully-closed Module agrees with the setting of Pn002 = n.X□□□. | *1 |
| A.050: Combination Error (The capacities of the SERVOPACK and Servomotor do not match.) | The SERVOPACK and Servomotor capacities do not match each other. | Confirm that the following condition is met: $1/4 \leq (\text{Servomotor capacity}/\text{SERVOPACK capacity}) \leq 4$ | Select a proper combination of the SERVOPACK and Servomotor capacities. | *1 |
| | A failure occurred in the encoder. | Replace the encoder and check to see if the alarm still occurs. | Replace the Servomotor or encoder. | – |
| | A failure occurred in the SERVOPACK. | – | The SERVOPACK may be faulty. Replace the SERVOPACK. | – |
| A.051: Unsupported Device Alarm | The motor parameter file was not written to the linear encoder. (This applies only when not using a Serial Converter Unit.) | Check to see if the motor parameter file was written to the linear encoder. | Write the motor parameter file to the linear encoder. | *1 |
| | An unsupported Serial Converter Unit or encoder (e.g., an external encoder) is connected to the SERVOPACK. | Check the product combination specifications. | Change to a correct combination of models. | – |

Continued on next page.

4.1 SERVOPACKs with Analog Voltage/Pulse Train References

4.1.3 Troubleshooting Alarms

Continued from previous page.

| Alarm Number: Alarm Name | Possible Cause | Confirmation | Correction | Reference |
|--|--|-----------------------------|---|-----------|
| A.070: Motor Type Change Detected (The connected motor is a differ- ent type of motor from the previ- ously connected motor.) | A Rotary Servomotor was removed and a Linear Servomotor was connected. | — | Set the parameters for a Linear Servomotor and reset the motor type alarm. Then, turn the power supply to the SERVOPACK OFF and ON again. | *1 |
| | A Linear Servomotor was removed and a Rotary Servomotor was connected. | — | Set the parameters for a Rotary Servomotor and reset the motor type alarm. Then, turn the power supply to the SERVOPACK OFF and ON again. | *1 |
| A.080: Linear Encoder Pitch Setting Error | The setting of Pn282 (Linear Encoder Scale Pitch) has not been changed from the default setting. | Check the setting of Pn282. | Correct the setting of Pn282. | *1 |
| A.0b0: Invalid Servo ON Command Alarm | The /S-ON (Servo ON) signal was input from the host controller after a utility function that turns ON the Servomotor was executed. | — | Turn the power supply to the SERVOPACK OFF and ON again. Or, execute a software reset. | *1 |

Continued on next page.

Continued from previous page.

| Alarm Number: Alarm Name | Possible Cause | Confirmation | Correction | Reference |
|--|---|--|--|-----------|
| A.100: Overcurrent Detected (An overcurrent flowed through the power trans- istor or the heat sink overheated.) | The Main Circuit Cable is not wired correctly or there is faulty contact. | Check the wiring. | Correct the wiring. | *1 |
| | There is a short-circuit or ground fault in a Main Circuit Cable. | Check for short-circuits across Servomotor phases U, V, and W, or between the ground and Servomotor phases U, V, and W. | The cable may be short-circuited. Replace the cable. | *1 |
| | There is a short-circuit or ground fault inside the Servomotor. | Check for short-circuits across Servomotor phases U, V, and W, or between the ground and Servomotor phases U, V, or W. | The Servomotor may be faulty. Replace the Servomotor. | *1 |
| | There is a short-circuit or ground fault inside the SERVOPACK. | Check for short-circuits across the Servomotor connection terminals U, V, and W on the SERVOPACK, or between the ground and terminals U, V, or W. | The SERVOPACK may be faulty. Replace the SERVOPACK. | *1 |
| | The regenerative resistor is not wired correctly or there is faulty contact. | Check the wiring. | Correct the wiring. | *1 |
| | The dynamic brake (DB, emergency stop executed from the SERVOPACK) was frequently activated, or a DB overload alarm occurred. | Check the power consumed by the DB resistor to see how frequently the DB is being used. Or, check the alarm display to see if a DB overload alarm (A.730 or A.731) has occurred. | Change the SERVOPACK model, operating methods, or the mechanisms so that the dynamic brake does not need to be used so frequently. | — |
| | The regenerative processing capacity was exceeded. | Check the regenerative load ratio in the SigmaWin+ Motion Monitor Tab Page to see how frequently the regenerative resistor is being used. | Recheck the operating conditions and load. | *4 |
| | The SERVOPACK regenerative resistance is too small. | Check the regenerative load ratio in the SigmaWin+ Motion Monitor Tab Page to see how frequently the regenerative resistor is being used. | Change the regenerative resistance to a value larger than the SERVOPACK minimum allowable resistance. | *4 |

Continued on next page.

4.1 SERVOPACKs with Analog Voltage/Pulse Train References

4.1.3 Troubleshooting Alarms

Continued from previous page.

| Alarm Number: Alarm Name | Possible Cause | Confirmation | Correction | Reference |
|--|--|---|--|-----------|
| A.100: Overcurrent Detected (An overcurrent flowed through the power tran- sistor or the heat sink overheated.) | A heavy load was applied while the Ser- vomotor was stopped or running at a low speed. | Check to see if the operating conditions exceed Servo Drive specifications. | Reduce the load applied to the Servomotor. Or, increase the operating speed. | - |
| | A malfunction was caused by noise. | Improve the noise envi- ronment, e.g. by improving the wiring or installation conditions, and check to see if the alarm still occurs. | Implement countermea- sures against noise, such as correct wiring of the FG. Use an FG wire size equivalent to the SERVO- PACK's main circuit wire size. | - |
| | A failure occurred in the SERVOPACK. | - | Turn the power supply to the SERVOPACK OFF and ON again. If an alarm still occurs, the SERVOPACK may be faulty. Replace the SERVOPACK. | - |
| A.101: Motor Overcur- rent Detected (The current to the motor exceeded the allowable cur- rent.) | The Main Circuit Cable is not wired correctly or there is faulty contact. | Check the wiring. | Correct the wiring. | *1 |
| | There is a short-circuit or ground fault in a Main Circuit Cable. | Check for short-circuits across cable phases U, V, and W, or between the ground and cable phases U, V, and W. | The cable may be short- circuited. Replace the cable. | *1 |
| | There is a short-circuit or ground fault inside the Servomotor. | Check for short-circuits across Servomotor phases U, V, and W, or between the ground and Servomotor phases U, V, or W. | The Servomotor may be faulty. Replace the Servo- motor. | *1 |
| | There is a short-circuit or ground fault inside the SERVOPACK. | Check for short-circuits across the Servomotor connection terminals U, V, and W on the SER- VOPACK, or between the ground and termi- nals U, V, or W. | The SERVOPACK may be faulty. Replace the SER- VOPACK. | *1 |
| | A heavy load was applied while the Ser- vomotor was stopped or running at a low speed. | Check to see if the operating conditions exceed Servo Drive specifications. | Reduce the load applied to the Servomotor. Or, increase the operating speed. | - |

Continued on next page.

Continued from previous page.

| Alarm Number: Alarm Name | Possible Cause | Confirmation | Correction | Reference |
|---|--|---|---|-----------|
| A.101: Motor Overcurrent Detected (The current to the motor exceeded the allowable current.) | A malfunction was caused by noise. | Improve the noise environment, e.g. by improving the wiring or installation conditions, and check to see if the alarm still occurs. | Implement countermeasures against noise, such as correct wiring of the FG. Use an FG wire size equivalent to the SERVOPACK's main circuit wire size. | – |
| | A failure occurred in the SERVOPACK. | – | Turn the power supply to the SERVOPACK OFF and ON again. If an alarm still occurs, the SERVOPACK may be faulty. Replace the SERVOPACK. | – |
| A.300: Regeneration Error | When using the built-in regenerative resistor, the jumper between the regenerative resistor terminals (B2 and B3) was removed from one of the following SERVOPACKs: SGD7S-3R8A, -5R5A, -7R6A, -120A, -180A, -200A, or -330A. | Check to see if the jumper is connected between power supply terminals B2 and B3.*5 | Correctly connect a jumper. | *1 |
| | The External Regenerative Resistor or Regenerative Resistor Unit is not wired correctly, or was removed or disconnected. | Check the wiring of the External Regenerative Resistor or Regenerative Resistor Unit.*5 | Correct the wiring of the External Regenerative Resistor or Regenerative Resistor Unit. | *1 |
| | Pn600 (Regenerative Resistor Capacity) is not set to 0 and an External Regenerative Resistor is not connected to one of the following SERVOPACKs: SGD7S-R70A, -R90A, -1R6A, -2R8A, -R70F, -R90F, -2R1F, or -2R8F. | Check to see if an External Regenerative Resistor is connected and check the setting of Pn600. | Connect an External Regenerative Resistor, or set Pn600 (Regenerative Resistor Capacity) to 0 (setting unit: x10 W) if no Regenerative Resistor is required. | *1 |
| | An External Regenerative Resistor is not connected to one of the following SERVOPACKs: SGD7S-470A, -550A, -590A, or -780A. | Check to see if an External Regenerative Resistor or a Regenerative Resistor Unit is connected and check the setting of Pn600. | Connect an External Regenerative Resistor and set Pn600 to an appropriate value, or connect a Regenerative Resistor Unit and set Pn600 to 0. | *1 |
| | A failure occurred in the SERVOPACK. | – | While the main circuit power supply is OFF, turn the control power supply to the SERVOPACK OFF and ON again. If the alarm still occurs, the SERVOPACK may be faulty. Replace the SERVOPACK. | – |

Continued on next page.

4.1 SERVOPACKs with Analog Voltage/Pulse Train References

4.1.3 Troubleshooting Alarms

Continued from previous page.

| Alarm Number: Alarm Name | Possible Cause | Confirmation | Correction | Reference |
|------------------------------------|---|--|---|-----------|
| A.320: Regenerative Overload | The power supply voltage exceeded the specified range. | Measure the power supply voltage. | Set the power supply voltage within the specified range. | – |
| | The external regenerative resistance value or regenerative resistor capacity is too small, or there has been a continuous regeneration state. | Check the operating conditions or the capacity using the SigmaJunmaSize+ Capacity Selection Software or other means. | Change the regenerative resistance value or capacity. Reconsider the operating conditions using the SigmaJunmaSize+ Capacity Selection Software or other means. | *4 |
| | There was a continuous regeneration state because a negative load was continuously applied. | Check the load applied to the Servomotor during operation. | Reconsider the system including the servo, machine, and operating conditions. | – |
| | The setting of Pn600 (Regenerative Resistor Capacity) is smaller than the capacity of the External Regenerative Resistor. | Check to see if a Regenerative Resistor is connected and check the setting of Pn600. | Correct the setting of Pn600. | *1 |
| | The setting of Pn603 (Regenerative Resistance) is smaller than the capacity of the External Regenerative Resistor. | Check to see if a Regenerative Resistor is connected and check the setting of Pn603. | Correct the setting of Pn603. | *1 |
| | The external regenerative resistance is too high. | Check the regenerative resistance. | Change the regenerative resistance to a correct value or use an External Regenerative Resistor of an appropriate capacity. | *4 |
| | A failure occurred in the SERVOPACK. | – | The SERVOPACK may be faulty. Replace the SERVOPACK. | – |

Continued on next page.

Continued from previous page.

| Alarm Number: Alarm Name | Possible Cause | Confirmation | Correction | Reference |
|--|---|--|---|-----------|
| A.330: Main Circuit Power Supply Wiring Error (Detected when the main circuit power supply is turned ON.) | The regenerative resistor was disconnected when the SERVOPACK power supply voltage was high. | Measure the resistance of the regenerative resistor using a measuring instrument. | If you are using the regenerative resistor built into the SERVOPACK, replace the SERVOPACK. If you are using an External Regenerative Resistor, replace the External Regenerative Resistor. | – |
| | DC power was supplied when an AC power supply input was specified in the settings. | Check the power supply to see if it is a DC power supply. | Correct the power supply setting to match the actual power supply. | *1 |
| | AC power was supplied when a DC power supply input was specified in the settings. | Check the power supply to see if it is an AC power supply. | Correct the power supply setting to match the actual power supply. | *1 |
| | Pn600 (Regenerative Resistor Capacity) is not set to 0 and an External Regenerative Resistor is not connected to one of the following SERVOPACKs: SGD7S-R70A, -R90A, -1R6A, -2R8A, -R70F, -R90F, -2R1F, or -2R8F. | Check to see if an External Regenerative Resistor is connected and check the setting of Pn600. | Connect an External Regenerative Resistor, or if an External Regenerative Resistor is not required, set Pn600 to 0. | *1 |
| | A failure occurred in the SERVOPACK. | – | The SERVOPACK may be faulty. Replace the SERVOPACK. | – |

Continued on next page.

4.1 SERVOPACKs with Analog Voltage/Pulse Train References

4.1.3 Troubleshooting Alarms

Continued from previous page.

| Alarm Number: Alarm Name | Possible Cause | Confirmation | Correction | Reference |
|---|---|--|---|-----------|
| A.400: Overvoltage (Detected in the main circuit power supply section of the SERVOPACK.) | The power supply voltage exceeded the specified range. | Measure the power supply voltage. | Set the AC/DC power supply voltage within the specified range. | - |
| | The power supply is not stable or was influenced by a lighting surge. | Measure the power supply voltage. | Improve the power supply conditions, install a surge absorber, and then turn the power supply OFF and ON again. If an alarm still occurs, the SERVOPACK may be faulty. Replace the SERVOPACK. | - |
| | The voltage for AC power supply was too high during acceleration or deceleration. | Check the power supply voltage and the speed and torque during operation. | Set the AC power supply voltage within the specified range. | - |
| | The external regenerative resistance is too high for the operating conditions. | Check the operating conditions and the regenerative resistance. | Select a regenerative resistance value that is appropriate for the operating conditions and load. | *4 |
| | The moment of inertia ratio or mass ratio exceeded the allowable value. | Check to see if the moment of inertia ratio or mass ratio is within the allowable range. | Increase the deceleration time, or reduce the load. | - |
| | A failure occurred in the SERVOPACK. | - | While the main circuit power supply is OFF, turn the control power supply to the SERVOPACK OFF and ON again. If an alarm still occurs, the SERVOPACK may be faulty. Replace the SERVOPACK. | - |
| A.410: Undervoltage (Detected in the main circuit power supply section of the SERVOPACK.) | The power supply voltage went below the specified range. | Measure the power supply voltage. | Set the power supply voltage within the specified range. | - |
| | The power supply voltage dropped during operation. | Measure the power supply voltage. | Increase the power supply capacity. | - |
| | A momentary power interruption occurred. | Measure the power supply voltage. | If you have changed the setting of Pn509 (Momentary Power Interruption Hold Time), decrease the setting. | *1 |
| | The SERVOPACK fuse is blown out. | - | Replace the SERVOPACK and connect a reactor to the DC reactor terminals (⊖1 and ⊖2) on the SERVOPACK. | - |
| | A failure occurred in the SERVOPACK. | - | The SERVOPACK may be faulty. Replace the SERVOPACK. | - |

Continued on next page.

Continued from previous page.

| Alarm Number: Alarm Name | Possible Cause | Confirmation | Correction | Reference |
|--|---|--|---|-----------|
| A.510: Overspeed (The motor exceeded the maximum speed.) | The order of phases U, V, and W in the motor wiring is not correct. | Check the wiring of the Servomotor. | Make sure that the Servomotor is correctly wired. | – |
| | A reference value that exceeded the over-speed detection level was input. | Check the input reference. | Reduce the reference value. Or, adjust the gain. | *1 |
| | The motor exceeded the maximum speed. | Check the waveform of the motor speed. | Reduce the speed reference input gain and adjust the servo gain. Or, reconsider the operating conditions. | *1 |
| | A failure occurred in the SERVOPACK. | – | The SERVOPACK may be faulty. Replace the SERVOPACK. | – |
| A.511: Encoder Output Pulse Overspeed | The encoder output pulse frequency exceeded the limit. | Check the encoder output pulse setting. | Decrease the setting of Pn212 (Number of Encoder Output Pulses) or Pn281 (Encoder Output Resolution). | *1 |
| | The encoder output pulse frequency exceeded the limit because the motor speed was too high. | Check the encoder output pulse setting and the motor speed. | Reduce the motor speed. | – |
| A.520: Vibration Alarm | Abnormal oscillation was detected in the motor speed. | Check for abnormal motor noise, and check the speed and torque waveforms during operation. | Reduce the motor speed. Or, reduce the setting of Pn100 (Speed Loop Gain). | *1 |
| | The setting of Pn103 (Moment of Inertia Ratio) is greater than the actual moment of inertia or was greatly changed. | Check the moment of inertia ratio or mass ratio. | Set Pn103 (Moment of Inertia Ratio) to an appropriate value. | *1 |
| | The vibration detection level (Pn312 or Pn384) is not suitable. | Check that the vibration detection level (Pn312 or Pn384) is suitable. | Set a suitable vibration detection level (Pn312 or Pn384). | *1 |
| A.521: Autotuning Alarm (Vibration was detected while executing the custom tuning, Easy FFT, or the tuning-less function.) | The Servomotor vibrated considerably while performing the tuning-less function. | Check the waveform of the motor speed. | Reduce the load so that the moment of inertia ratio is within the allowable value. Or increase the load level or reduce the rigidity level in the tuning-less level settings. | *1 |
| | The Servomotor vibrated considerably while performing custom tuning or Easy FFT. | Check the waveform of the motor speed. | Check the operating procedure of corresponding function and implement corrections. | *1 |
| A.550: Maximum Speed Setting Error | The setting of Pn385 (Maximum Motor Speed) is greater than the maximum speed. | Check the setting of Pn385, and the upper limits of the maximum motor speed setting and the encoder output resolution setting. | Set Pn385 to a value that does not exceed the maximum motor speed. | *1 |

Continued on next page.

4.1 SERVOPACKs with Analog Voltage/Pulse Train References

4.1.3 Troubleshooting Alarms

Continued from previous page.

| Alarm Number: Alarm Name | Possible Cause | Confirmation | Correction | Reference |
|--|--|---|--|-----------|
| A.710: Instantaneous Overload A.720: Continuous Overload | The wiring is not correct or there is a faulty connection in the motor or encoder wiring. | Check the wiring. | Make sure that the Servomotor and encoder are correctly wired. | *1 |
| | Operation was performed that exceeded the overload protection characteristics. | Check the motor overload characteristics and Run command. | Reconsider the load and operating conditions. Or, increase the motor capacity. | – |
| | An excessive load was applied during operation because the Servomotor was not driven due to mechanical problems. | Check the operation reference and motor speed. | Correct the mechanical problem. | – |
| | There is an error in the setting of Pn282 (Linear Encoder Scale Pitch). | Check the setting of Pn282. | Correct the setting of Pn282. | *1 |
| | There is an error in the setting of Pn080 = n.□□X□ (Motor Phase Sequence Selection). | Check the setting of Pn080 = n.□□X□. | Set Pn080 = n.□□X□ to an appropriate value. | *1 |
| | A failure occurred in the SERVOPACK. | – | The SERVOPACK may be faulty. Replace the SERVOPACK. | – |
| A.730 and A.731: Dynamic Brake Overload (An excessive power consumption by the dynamic brake was detected.) | The Servomotor was rotated by an external force. | Check the operation status. | Implement measures to ensure that the motor will not be rotated by an external force. | – |
| | When the Servomotor was stopped with the dynamic brake, the rotational or linear kinetic energy exceeded the capacity of the dynamic brake resistor. | Check the power consumed by the DB resistor to see how frequently the DB is being used. | Reconsider the following: • Reduce the Servomotor command speed. • Decrease the moment of inertia ratio or mass ratio. • Reduce the frequency of stopping with the dynamic brake. | – |
| | A failure occurred in the SERVOPACK. | – | The SERVOPACK may be faulty. Replace the SERVOPACK. | – |
| A.740: Inrush Current Limiting Resistor Overload (The main circuit power supply was frequently turned ON and OFF.) | The allowable frequency of the inrush current limiting resistor was exceeded when the main circuit power supply was turned ON and OFF. | – | Reduce the frequency of turning the main circuit power supply ON and OFF. | – |
| | A failure occurred in the SERVOPACK. | – | The SERVOPACK may be faulty. Replace the SERVOPACK. | – |

Continued on next page.

Continued from previous page.

| Alarm Number: Alarm Name | Possible Cause | Confirmation | Correction | Reference |
|---|--|---|--|-----------|
| A.7A1: Internal Temperature Error 1 (Control Board Temperature Error) | The surrounding temperature is too high. | Check the surrounding temperature using a thermometer. Or, check the operating status with the SERVOPACK installation environment monitor. | Decrease the surrounding temperature by improving the SERVOPACK installation conditions. | *1 |
| | An overload alarm was reset by turning OFF the power supply too many times. | Check the alarm display to see if there is an overload alarm. | Change the method for resetting the alarm. | – |
| | There was an excessive load or operation was performed that exceeded the regenerative processing capacity. | Use the accumulated load ratio to check the load during operation, and use the regenerative load ratio to check the regenerative processing capacity. | Reconsider the load and operating conditions. | – |
| | The SERVOPACK installation orientation is not correct or there is insufficient space around the SERVOPACK. | Check the SERVOPACK installation conditions. | Install the SERVOPACK according to specifications. | *1 |
| | A failure occurred in the SERVOPACK. | – | The SERVOPACK may be faulty. Replace the SERVOPACK. | – |
| A.7A2: Internal Temperature Error 2 (Power Board Temperature Error) | The surrounding temperature is too high. | Check the surrounding temperature using a thermometer. Or, check the operating status with the SERVOPACK installation environment monitor. | Decrease the surrounding temperature by improving the SERVOPACK installation conditions. | *1 |
| | An overload alarm was reset by turning OFF the power supply too many times. | Check the alarm display to see if there is an overload alarm. | Change the method for resetting the alarm. | – |
| | There was an excessive load or operation was performed that exceeded the regenerative processing capacity. | Use the accumulated load ratio to check the load during operation, and use the regenerative load ratio to check the regenerative processing capacity. | Reconsider the load and operating conditions. | – |
| | The SERVOPACK installation orientation is not correct or there is insufficient space around the SERVOPACK. | Check the SERVOPACK installation conditions. | Install the SERVOPACK according to specifications. | *1 |
| | A failure occurred in the SERVOPACK. | – | The SERVOPACK may be faulty. Replace the SERVOPACK. | – |
| A.7A3: Internal Temperature Sensor Error (An error occurred in the temperature sensor circuit.) | A failure occurred in the SERVOPACK. | – | The SERVOPACK may be faulty. Replace the SERVOPACK. | – |

Continued on next page.

4.1 SERVOPACKs with Analog Voltage/Pulse Train References

4.1.3 Troubleshooting Alarms

Continued from previous page.

| Alarm Number: Alarm Name | Possible Cause | Confirmation | Correction | Reference |
|--|---|--|---|-----------|
| A.7Ab: SERVOPACK Built-in Fan Stopped | The fan inside the SERVOPACK stopped. | Check for foreign matter inside the SERVOPACK. | Remove foreign matter from the SERVOPACK. If an alarm still occurs, the SERVOPACK may be faulty. Replace the SERVOPACK. | – |
| A.810: Encoder Backup Alarm (Detected at the encoder, but only when an absolute encoder is used.) | The power to the absolute encoder was turned ON for the first time. | Check to see if the power supply was turned ON for the first time. | Set up the encoder. | *1 |
| | The Encoder Cable was disconnected and then connected again. | Check to see if the power supply was turned ON for the first time. | Check the encoder connection and set up the encoder. | *1 |
| | Power is not being supplied both from the control power supply (+5 V) from the SERVOPACK and from the battery power supply. | Check the encoder connector battery and the connector status. | Replace the battery or implement similar measures to supply power to the encoder, and set up the encoder. | *1 |
| | A failure occurred in the absolute encoder. | – | If the alarm still occurs after setting up the encoder again, replace the Servomotor. | – |
| | A failure occurred in the SERVOPACK. | – | The SERVOPACK may be faulty. Replace the SERVOPACK. | – |
| A.820: Encoder Check-sum Alarm (Detected at the encoder.) | A failure occurred in the encoder. | – | <ul style="list-style-type: none"> ■ When Using an Absolute Encoder Set up the encoder again. If the alarm still occurs, the Servomotor may be faulty. Replace the Servomotor. ■ When Using a Single-turn Absolute Encoder or Incremental Encoder <ul style="list-style-type: none"> • The Servomotor may be faulty. Replace the Servomotor. • The linear encoder may be faulty. Replace the linear encoder. | *1 |
| | A failure occurred in the SERVOPACK. | – | The SERVOPACK may be faulty. Replace the SERVOPACK. | – |
| A.830: Encoder Battery Alarm (The absolute encoder battery voltage was lower than the specified level.) | The battery connection is faulty or a battery is not connected. | Check the battery connection. | Correct the battery connection. | *1 |
| | The battery voltage is lower than the specified value (2.7 V). | Measure the battery voltage. | Replace the battery. | *1 |
| | A failure occurred in the SERVOPACK. | – | The SERVOPACK may be faulty. Replace the SERVOPACK. | – |

Continued on next page.

Continued from previous page.

| Alarm Number: Alarm Name | Possible Cause | Confirmation | Correction | Reference |
|---|--|---|--|-----------|
| A.840: Encoder Data Alarm (Detected at the encoder.) | The encoder malfunctioned. | – | Turn the power supply to the SERVOPACK OFF and ON again. If an alarm still occurs, the Servomotor or linear encoder may be faulty. Replace the Servomotor or linear encoder. | – |
| | An error occurred in reading data from the linear encoder. | – | The linear encoder is not mounted within an appropriate tolerance. Correct the mounting of the linear encoder. | – |
| | Excessive speed occurred in the linear encoder. | – | Control the motor speed within the range specified by the linear encoder manufacturer and then turn ON the control power supply. | – |
| | The encoder malfunctioned due to noise. | – | Correct the wiring around the encoder by separating the Encoder Cable from the Servomotor Main Circuit Cable or by grounding the encoder. | – |
| | The polarity sensor is not wired correctly. | Check the wiring of the polarity sensor. | Correct the wiring of the polarity sensor. | – |
| | The polarity sensor failed. | – | Replace the polarity sensor. | – |
| A.850: Encoder Over-speed (Detected at the encoder when the control power supply is turned ON.) | Rotary Servomotor: The Servomotor speed was 200 min^{-1} or higher when the control power supply was turned ON. | Check the motor speed when the power supply is turned ON. | Reduce the Servomotor speed to a value less than 200 min^{-1} , and turn ON the control power supply. | – |
| | Linear Servomotor: The Servomotor exceeded the specified speed when the control power supply was turned ON. | Check the motor speed when the power supply is turned ON. | Control the motor speed within the range specified by the linear encoder manufacturer and then turn ON the control power supply. | – |
| | A failure occurred in the encoder. | – | Turn the power supply to the SERVOPACK OFF and ON again. If an alarm still occurs, the Servomotor or linear encoder may be faulty. Replace the Servomotor or linear encoder. | – |
| | A failure occurred in the SERVOPACK. | – | Turn the power supply to the SERVOPACK OFF and ON again. If an alarm still occurs, the SERVOPACK may be faulty. Replace the SERVOPACK. | – |

Continued on next page.

4.1 SERVOPACKs with Analog Voltage/Pulse Train References

4.1.3 Troubleshooting Alarms

Continued from previous page.

| Alarm Number: Alarm Name | Possible Cause | Confirmation | Correction | Reference |
|--|--|---|--|-----------|
| A.860: Encoder Overheated (Detected when a Rotary Servomotor, Absolute Linear Encoder, or Direct Drive Servomotor is connected. However, this alarm is not detected for SGMCS Servomotors with Incremental Encoders.) (Detected at the encoder.) | The surrounding air temperature around the Servomotor is too high. | Measure the surrounding air temperature around the Servomotor. | Reduce the surrounding air temperature of the Servomotor to 40°C or less. | – |
| | The Servomotor load is greater than the rated load. | Use the accumulated load ratio to check the load. | Operate the Servo Drive so that the motor load remains within the specified range. | *1 |
| | A failure occurred in the encoder. | – | Turn the power supply to the SERVOPACK OFF and ON again. If an alarm still occurs, the Servomotor or absolute linear encoder may be faulty. Replace the Servomotor or absolute linear encoder. | – |
| | A failure occurred in the SERVOPACK. | – | Turn the power supply to the SERVOPACK OFF and ON again. If an alarm still occurs, the SERVOPACK may be faulty. Replace the SERVOPACK. | – |
| A.861: Motor Overheated | The surrounding temperature around the Servomotor is too high. | Measure the surrounding temperature around the Servomotor. | Reduce the surrounding air temperature of the Servomotor to 40° or less. | – |
| | The motor load is greater than the rated load. | Check the load with the accumulated load ratio on the Motion Monitor Tab Page on the SigmaWin+. | Operate the Servo Drive so that the motor load remains within the specified range. | *1 |
| | A failure occurred in the Serial Converter Unit. | – | Turn the power supply to the SERVOPACK OFF and ON again. If an alarm still occurs, the Serial Converter Unit may be faulty. Replace the Serial Converter Unit. | – |
| | A failure occurred in the SERVOPACK. | – | Turn the power supply to the SERVOPACK OFF and ON again. If an alarm still occurs, the SERVOPACK may be faulty. Replace the SERVOPACK. | – |

Continued on next page.

Continued from previous page.

| Alarm Number: Alarm Name | Possible Cause | Confirmation | Correction | Reference |
|---|---|---|---|-----------|
| A.862: Overheat Alarm | The surrounding temperature is too high. | Check the surrounding temperature using a thermometer. | Lower the surrounding temperature by improving the installation conditions of the Linear Servomotor or the machine. | - |
| | The overheat protection input signal line is disconnected or short-circuited. | Check the input voltage with the overheat protection input information on the Motion Monitor Tab Page on the SigmaWin+. | Repair the line for the overheat protection input signal. | - |
| | An overload alarm was reset by turning OFF the power supply too many times. | Check the alarm display to see if there is an overload alarm. | Change the method for resetting the alarm. | - |
| | Operation was performed under an excessive load. | Use the accumulated load ratio to check the load during operation. | Reconsider the load and operating conditions. | - |
| | A failure occurred in the SERVOPACK. | - | The SERVOPACK may be faulty. Replace the SERVOPACK. | - |
| | The temperature detection circuit in the Linear Servomotor is faulty or the sensor attached to the machine is faulty. | - | The temperature detection circuit in the Linear Servomotor may be faulty or the sensor attached to the machine may be faulty. Replace the Linear Servomotor or repair the sensor attached to the machine. | - |
| A.890: Encoder Scale Error | A failure occurred in the linear encoder. | - | The linear encoder may be faulty. Replace the linear encoder. | - |
| A.891: Encoder Module Error | A failure occurred in the linear encoder. | - | Turn the power supply to the SERVOPACK OFF and ON again. If an alarm still occurs, the linear encoder may be faulty. Replace the linear encoder. | - |
| A.8A0: External Encoder Error | Setting the origin of the absolute linear encoder failed because the motor moved. | Before you set the origin, use the fully-closed feedback pulse counter to confirm that the motor is not moving. | The motor must be stopped while setting the origin position. | *1 |
| | A failure occurred in the external encoder. | - | Replace the external encoder. | - |
| A.8A1: External Encoder Module Error | A failure occurred in the external encoder. | - | Replace the external encoder. | - |
| | A failure occurred in the Serial Converter Unit. | - | Replace the Serial Converter Unit. | - |
| A.8A2: External Incremental Encoder Sensor Error | A failure occurred in the external encoder. | - | Replace the external encoder. | - |
| A.8A3: External Absolute Encoder Position Error | A failure occurred in the external absolute encoder. | - | The external absolute encoder may be faulty. Refer to the encoder manufacturer's instruction manual for corrections. | - |

Continued on next page.

4.1 SERVOPACKs with Analog Voltage/Pulse Train References

4.1.3 Troubleshooting Alarms

Continued from previous page.

| Alarm Number: Alarm Name | Possible Cause | Confirmation | Correction | Reference |
|---|---|--|--|-----------|
| A.8A5: External Encoder Overspeed | An overspeed error was detected in the external encoder. | Check the maximum speed of the external encoder. | Keep the external encoder below its maximum speed. | – |
| A.8A6: External Encoder Overheated | An overheating error was detected in the external encoder. | – | Replace the external encoder. | – |
| A.b10: Speed Reference A/D Error (Detected when the servo is turned ON.) | A malfunction occurred in the speed reference input section. | – | Reset the alarm and restart operation. | *1 |
| | A failure occurred in the SERVOPACK. | – | Turn the power supply to the SERVOPACK OFF and ON again. If an alarm still occurs, the SERVOPACK may be faulty. Replace the SERVOPACK. | – |
| A.b11: Speed Reference A/D Data Error | A malfunction occurred in the speed reference input section. | – | Reset the alarm and restart operation. | *1 |
| | A failure occurred in the SERVOPACK. | – | Turn the power supply to the SERVOPACK OFF and ON again. If an alarm still occurs, the SERVOPACK may be faulty. Replace the SERVOPACK. | – |
| A.b20: Torque Reference A/D Error (Detected when the servo is turned ON.) | A malfunction occurred in the reading section for the torque reference input. | – | Reset the alarm and restart operation. | *1 |
| | A failure occurred in the SERVOPACK. | – | Turn the power supply to the SERVOPACK OFF and ON again. If an alarm still occurs, the SERVOPACK may be faulty. Replace the SERVOPACK. | – |
| A.b33: Current Detection Error 3 | A failure occurred in the current detection circuit. | – | Turn the power supply to the SERVOPACK OFF and ON again. If an alarm still occurs, the SERVOPACK may be faulty. Replace the SERVOPACK. | – |
| A.bF0: System Alarm 0 | A failure occurred in the SERVOPACK. | – | Turn the power supply to the SERVOPACK OFF and ON again. If an alarm still occurs, the SERVOPACK may be faulty. Replace the SERVOPACK. | – |
| A.bF1: System Alarm 1 | A failure occurred in the SERVOPACK. | – | Turn the power supply to the SERVOPACK OFF and ON again. If an alarm still occurs, the SERVOPACK may be faulty. Replace the SERVOPACK. | – |
| A.bF2: System Alarm 2 | A failure occurred in the SERVOPACK. | – | Turn the power supply to the SERVOPACK OFF and ON again. If an alarm still occurs, the SERVOPACK may be faulty. Replace the SERVOPACK. | – |

Continued on next page.

Continued from previous page.

| Alarm Number: Alarm Name | Possible Cause | Confirmation | Correction | Reference |
|--|--|--------------------------------------|---|-----------|
| A.bF3: System Alarm 3 | A failure occurred in the SERVOPACK. | — | Turn the power supply to the SERVOPACK OFF and ON again. If an alarm still occurs, the SERVOPACK may be faulty. Replace the SERVOPACK. | — |
| A.bF4: System Alarm 4 | A failure occurred in the SERVOPACK. | — | Turn the power supply to the SERVOPACK OFF and ON again. If an alarm still occurs, the SERVOPACK may be faulty. Replace the SERVOPACK. | — |
| A.bF5: System Alarm 5 | A failure occurred in the SERVOPACK. | — | Turn the power supply to the SERVOPACK OFF and ON again. If an alarm still occurs, the SERVOPACK may be faulty. Replace the SERVOPACK. | — |
| A.bF6: System Alarm 6 | A failure occurred in the SERVOPACK. | — | Turn the power supply to the SERVOPACK OFF and ON again. If an alarm still occurs, the SERVOPACK may be faulty. Replace the SERVOPACK. | — |
| A.bF7: System Alarm 7 | A failure occurred in the SERVOPACK. | — | Turn the power supply to the SERVOPACK OFF and ON again. If an alarm still occurs, the SERVOPACK may be faulty. Replace the SERVOPACK. | — |
| A.bF8: System Alarm 8 | A failure occurred in the SERVOPACK. | — | Turn the power supply to the SERVOPACK OFF and ON again. If an alarm still occurs, the SERVOPACK may be faulty. Replace the SERVOPACK. | — |
| A.C10: Servomotor Out of Control (Detected when the servo is turned ON.) | The order of phases U, V, and W in the motor wiring is not correct. | Check the Servomotor wiring. | Make sure that the Servomotor is correctly wired. | — |
| | There is an error in the setting of Pn080 = n.□□X□ (Motor Phase Sequence Selection). | Check the setting of Pn080 = n.□□X□. | Set Pn080 = n.□□X□ to an appropriate value. | *1 |
| | A failure occurred in the encoder. | — | If the motor wiring is correct and an alarm still occurs after turning the power supply OFF and ON again, the Servomotor or linear encoder may be faulty. Replace the Servomotor or linear encoder. | — |
| | A failure occurred in the SERVOPACK. | — | Turn the power supply to the SERVOPACK OFF and ON again. If an alarm still occurs, the SERVOPACK may be faulty. Replace the SERVOPACK. | — |

Continued on next page.

4.1 SERVOPACKs with Analog Voltage/Pulse Train References

4.1.3 Troubleshooting Alarms

Continued from previous page.

| Alarm Number: Alarm Name | Possible Cause | Confirmation | Correction | Reference |
|---|--|--|--|-----------|
| A.C20: Phase Detection Error | The linear encoder signal level is too low. | Check the voltage of the linear encoder signal. | Fine-tune the mounting of the scale head. Or, replace the linear encoder. | – |
| | The count-up direction of the linear encoder does not match the forward direction of the Moving Coil in the motor. | Check the setting of Pn080 = n.□□X□ (Motor Phase Sequence Selection). Check the installation orientation for the linear encoder and Moving Coil. | Change the setting of Pn080 = n.□□X□. Correctly reinstall the linear encoder or Moving Coil. | *1 |
| | The polarity sensor signal is being affected by noise. | – | Correct the FG wiring. Implement countermeasures against noise for the polarity sensor wiring. | – |
| | The setting of Pn282 (Linear Encoder Scale Pitch) is not correct. | Check the setting of Pn282 (Linear Encoder Scale Pitch). | Check the specifications of the linear encoder and set a correct value. | *1 |
| A.C21: Polarity Sensor Error | The polarity sensor is protruding from the Magnetic Way of the motor. | Check the polarity sensor. | Correctly reinstall the Moving Coil or Magnetic Way of the motor. | – |
| | The polarity sensor is not wired correctly. | Check the wiring of the polarity sensor. | Correct the wiring of the polarity sensor. | – |
| | The polarity sensor failed. | – | Replace the polarity sensor. | – |
| A.C22: Phase Information Disagreement | The SERVOPACK phase information is different from the linear encoder phase information. | – | Perform polarity detection. | *1 |

Continued on next page.

Continued from previous page.

| Alarm Number: Alarm Name | Possible Cause | Confirmation | Correction | Reference |
|--------------------------------------|--|--|--|-----------|
| A.C50: Polarity Detection Failure | The parameter settings are not correct. | Check the linear encoder specifications and feedback signal status. | The settings of Pn282 (Linear Encoder Scale Pitch) and Pn080 = n.□□X□ (Motor Phase Sequence Selection) may not match the installation. Set the parameters to correct values. | *1 |
| | There is noise on the scale signal. | Check to make sure that the frame grounds of the Serial Converter Unit and Servomotor are connected to the FG terminal on the SERVOPACK and that the FG terminal on the SERVOPACK is connected to the frame ground on the power supply. And, confirm that the shield is properly processed on the Linear Encoder Cable. Check to see if the detection reference is repeatedly output in one direction. | Implement appropriate countermeasures against noise for the Linear Encoder Cable. | — |
| | An external force was applied to the Moving Coil of the motor. | — | The polarity cannot be properly detected if the detection reference is 0 and the speed feedback is not 0 because of an external force, such as cable tension, applied to the Moving Coil. Implement measures to reduce the external force so that the speed feedback goes to 0. If the external force cannot be reduced, increase the setting of Pn481 (Polarity Detection Speed Loop Gain). | — |
| | The linear encoder resolution is too low. | Check the linear encoder scale pitch to see if it is within 100 μm. | If the linear encoder scale pitch is 100 μm or higher, the SERVOPACK cannot detect the correct speed feedback. Use a linear encoder scale pitch with higher resolution. (We recommend a pitch of 40 μm or less.) Or, increase the setting of Pn485 (Polarity Detection Reference Speed). However, increasing the setting of Pn485 will increase the Servomotor movement range that is required for polarity detection. | — |

Continued on next page.

Continued from previous page.

| Alarm Number: Alarm Name | Possible Cause | Confirmation | Correction | Reference |
|--|--|--------------------------------|---|-----------|
| A.C51: Overtravel Detected during Polarity Detection | The overtravel signal was detected during polarity detection. | Check the overtravel position. | Wire the overtravel signals. Execute polarity detection at a position where an overtravel signal would not be detected. | *1 |
| A.C52: Polarity Detection Not Completed | The servo was turned ON under the following circumstances. <ul style="list-style-type: none"> • Before polarity detection was completed • Before /P-DET was input | – | Input the /P-DET signal. | *1 |
| A.C53: Out of Range of Motion for Polarity Detection | The travel distance exceeded the setting of Pn48E (Polarity Detection Range) in the middle of detection. | – | Increase the setting of Pn48E (Polarity Detection Range). Or, increase the setting of Pn481 (Polarity Detection Speed Loop Gain). | – |
| A.C54: Polarity Detection Failure 2 | An external force was applied to the Servomotor. | – | Increase the setting of Pn495 (Polarity Detection Confirmation Force Reference). Increase the setting of Pn498 (Polarity Detection Allowable Error Range). Increasing the allowable error will also increase the motor temperature. | – |
| A.C80: Encoder Clear Error or Multiturn Limit Setting Error | A failure occurred in the encoder. | – | Turn the power supply to the SERVOPACK OFF and ON again. If an alarm still occurs, the Servomotor or linear encoder may be faulty. Replace the Servomotor or linear encoder. | – |
| | A failure occurred in the SERVOPACK. | – | Turn the power supply to the SERVOPACK OFF and ON again. If an alarm still occurs, the SERVOPACK may be faulty. Replace the SERVOPACK. | – |

Continued on next page.

Continued from previous page.

| Alarm Number: Alarm Name | Possible Cause | Confirmation | Correction | Reference |
|---|---|--|--|-----------|
| A.C90: Encoder Commu- nications Error | There is a faulty contact in the connector or the connector is not wired correctly for the encoder. | Check the condition of the encoder connector. | Reconnect the encoder connector and check the encoder wiring. | *1 |
| | There is a cable disconnection or short-circuit in the encoder. Or, the cable impedance is outside the specified values. | Check the condition of the Encoder Cable. | Use the Encoder Cable within the specified specifications. | – |
| | One of the following has occurred: corrosion caused by improper temperature, humidity, or gas, a short-circuit caused by entry of water drops or cutting oil, or faulty contact in connector caused by vibration. | Check the operating environment. | Improve the operating environment, and replace the cable. If the alarm still occurs, replace the SERVOPACK. | *1 |
| | A malfunction was caused by noise. | – | Correct the wiring around the encoder by separating the Encoder Cable from the Servomotor Main Circuit Cable or by grounding the encoder. | *1 |
| | A failure occurred in the SERVOPACK. | – | Connect the SERVOMOTOR to another SERVOPACK, and turn ON the control power supply. If no alarm occurs, the SERVOPACK may be faulty. Replace the SERVOPACK. | – |
| A.C91: Encoder Commu- nications Position Data Acceleration Rate Error | Noise entered on the signal lines because the Encoder Cable is bent or the sheath is damaged. | Check the condition of the Encoder Cable and connectors. | Check the Encoder Cable to see if it is installed correctly. | *1 |
| | The Encoder Cable is bundled with a high-current line or installed near a high-current line. | Check the installation condition of the Encoder Cable. | Confirm that there is no surge voltage on the Encoder Cable. | – |
| | There is variation in the FG potential because of the influence of machines on the Servomotor side, such as a welder. | Check the installation condition of the Encoder Cable. | Properly ground the machine to separate it from the FG of the encoder. | – |

Continued on next page.

4.1 SERVOPACKs with Analog Voltage/Pulse Train References

4.1.3 Troubleshooting Alarms

Continued from previous page.

| Alarm Number: Alarm Name | Possible Cause | Confirmation | Correction | Reference |
|--|--|---------------------------------|--|-----------|
| A.C92: Encoder Commu- nications Timer Error | Noise entered on the signal line from the encoder. | – | Implement countermeasures against noise for the encoder wiring. | *1 |
| | Excessive vibration or shock was applied to the encoder. | Check the operating conditions. | Reduce machine vibration. Correctly install the Servomotor or linear encoder. | – |
| | A failure occurred in the encoder. | – | Turn the power supply to the SERVOPACK OFF and ON again. If an alarm still occurs, the Servomotor or linear encoder may be faulty. Replace the Servomotor or linear encoder. | – |
| | A failure occurred in the SERVOPACK. | – | Turn the power supply to the SERVOPACK OFF and ON again. If an alarm still occurs, the SERVOPACK may be faulty. Replace the SERVOPACK. | – |
| A.CA0: Encoder Parameter Error | A failure occurred in the encoder. | – | Turn the power supply to the SERVOPACK OFF and ON again. If an alarm still occurs, the Servomotor or linear encoder may be faulty. Replace the Servomotor or linear encoder. | – |
| | A failure occurred in the SERVOPACK. | – | Turn the power supply to the SERVOPACK OFF and ON again. If an alarm still occurs, the SERVOPACK may be faulty. Replace the SERVOPACK. | – |

Continued on next page.

Continued from previous page.

| Alarm Number: Alarm Name | Possible Cause | Confirmation | Correction | Reference |
|---|--|--|--|-----------|
| A.Cb0: Encoder Echo- back Error | The encoder is wired incorrectly or there is faulty contact. | Check the wiring of the encoder. | Make sure that the encoder is correctly wired. | *1 |
| | The specifications of the Encoder Cable are not correct and noise entered on it. | – | Use a shielded twisted-pair wire cable or a screened twisted-pair cable with conductors of at least 0.12 mm ² . | – |
| | The Encoder Cable is too long and noise entered on it. | – | <ul style="list-style-type: none"> Rotary Servomotors: The Encoder Cable wiring distance must be 50 m max. Linear Servomotors: The Encoder Cable wiring distance must be 20 m max. | – |
| | There is variation in the FG potential because of the influence of machines on the Servomotor side, such as a welder. | Check the condition of the Encoder Cable and connectors. | Properly ground the machine to separate it from the FG of the encoder. | – |
| | Excessive vibration or shock was applied to the encoder. | Check the operating conditions. | Reduce machine vibration. Correctly install the Servomotor or linear encoder. | – |
| | A failure occurred in the encoder. | – | Turn the power supply to the SERVOPACK OFF and ON again. If an alarm still occurs, the Servomotor or linear encoder may be faulty. Replace the Servomotor or linear encoder. | – |
| | A failure occurred in the SERVOPACK. | – | Turn the power supply to the SERVOPACK OFF and ON again. If an alarm still occurs, the SERVOPACK may be faulty. Replace the SERVOPACK. | – |
| A.CC0: Multiturn Limit Disagreement | When using a Direct Drive Servomotor, the setting of Pn205 (Multiturn Limit) does not agree with the encoder. | Check the setting of Pn205. | Correct the setting of Pn205 (0 to 65,535). | *1 |
| | The multiturn limit of the encoder is different from that of the SERVOPACK. Or, the multiturn limit of the SERVOPACK has been changed. | Check the setting of Pn205 in the SERVOPACK. | Change the setting if the alarm occurs. | *1 |
| | A failure occurred in the SERVOPACK. | – | Turn the power supply to the SERVOPACK OFF and ON again. If an alarm still occurs, the SERVOPACK may be faulty. Replace the SERVOPACK. | – |

Continued on next page.

4.1 SERVOPACKs with Analog Voltage/Pulse Train References

4.1.3 Troubleshooting Alarms

Continued from previous page.

| Alarm Number: Alarm Name | Possible Cause | Confirmation | Correction | Reference |
|--|--|--|--|-----------|
| A.CF1: Reception Failed Error in Feed- back Option Module Commu- nications | The cable between the Serial Converter Unit and SERVOPACK is not wired correctly or there is a faulty contact. | Check the wiring of the external encoder. | Correctly wire the cable between the Serial Converter Unit and SERVOPACK. | *1 |
| | A specified cable is not being used between Serial Converter Unit and SERVOPACK. | Check the wiring specifications of the external encoder. | Use a specified cable. | - |
| | The cable between the Serial Converter Unit and SERVOPACK is too long. | Measure the length of the cable that connects the Serial Converter Unit. | The length of the cable between the Serial Converter Unit and SERVOPACK must be 20 m or less. | - |
| | The sheath on cable between the Serial Converter Unit and SERVOPACK is broken. | Check the cable that connects the Serial Converter Unit. | Replace the cable between the Serial Converter Unit and SERVOPACK. | - |
| A.CF2: Timer Stopped Error in Feed- back Option Module Commu- nications | Noise entered the cable between the Serial Converter Unit and SERVOPACK. | - | Correct the wiring around the Serial Converter Unit, e.g., separate I/O signal lines from the Main Circuit Cables or ground. | - |
| | A failure occurred in the Serial Converter Unit. | - | Replace the Serial Converter Unit. | - |
| | A failure occurred in the SERVOPACK. | - | Replace the SERVOPACK. | - |
| A.d00: Position Devia- tion Overflow (The setting of Pn520 (Position Deviation Overflow Alarm Level) was exceeded by the position deviation while the servo was ON.) | The Servomotor U, V, and W wiring is not correct. | Check the wiring of the Servomotor's Main Circuit Cables. | Make sure that there are no faulty contacts in the wiring for the Servomotor and encoder. | - |
| | The frequency of the position reference pulse is too high. | Reduce the reference pulse frequency and try operating the SERVOPACK. | Reduce the position reference pulse frequency or the reference acceleration rate, or reconsider the electronic gear ratio. | *1 |
| | The acceleration of the position reference is too high. | Reduce the reference acceleration and try operating the SERVOPACK. | Apply smoothing, i.e., by using Pn216 (Position Reference Acceleration/Deceleration Time Constant). | *1 |
| | The setting of Pn520 (Position Deviation Overflow Alarm Level) is too low for the operating conditions. | Check Pn520 (Position Deviation Overflow Alarm Level) to see if it is set to an appropriate value. | Optimize the setting of Pn520. | *1 |
| | A failure occurred in the SERVOPACK. | - | Turn the power supply to the SERVOPACK OFF and ON again. If an alarm still occurs, the SERVOPACK may be faulty. Replace the SERVOPACK. | - |

Continued on next page.

Continued from previous page.

| Alarm Number: Alarm Name | Possible Cause | Confirmation | Correction | Reference |
|---|---|--|---|-----------|
| A.d01: Position Deviation Overflow Alarm at Servo ON | The servo was turned ON after the position deviation exceeded the setting of Pn526 (Position Deviation Overflow Alarm Level at Servo ON) while the servo was OFF. | Check the position deviation while the servo is OFF. | Set the position deviation to be cleared while the servo is OFF. Optimize the setting of Pn526 (Position Deviation Overflow Alarm Level at Servo ON). | *1 |
| A.d02: Position Deviation Overflow Alarm for Speed Limit at Servo ON | If position deviation remains in the deviation counter, the setting of Pn529 or Pn584 (Speed Limit Level at Servo ON) limits the speed when the servo is turned ON. This alarm occurs if reference pulses are input and the setting of Pn520 (Position Deviation Overflow Alarm Level) is exceeded. | – | Set the position deviation to be cleared while the servo is OFF. Optimize the setting of Pn520 (Position Deviation Overflow Alarm Level). Or, adjust the setting of Pn529 or Pn584 (Speed Limit Level at Servo ON). | *1 |
| A.d10: Motor-Load Position Deviation Overflow | The motor direction and external encoder installation orientation are backward. | Check the motor direction and the external encoder installation orientation. | Install the external encoder in the opposite direction, or change the setting of Pn002 = n.X□□□ (External Encoder Usage) to reverse the direction. | *1 |
| | There is an error in the connection between the load (e.g., stage) and external encoder coupling. | Check the coupling of the external encoder. | Check the mechanical coupling. | – |
| A.d30: Position Data Overflow | The position data exceeded $\pm 1,879,048,192$. | Check the input reference pulse counter. | Reconsider the operating specifications. | – |
| A.E71: Safety Option Module Detection Failure | There is a faulty connection between the SERVOPACK and the Safety Option Module. | Check the connection between the SERVOPACK and the Safety Option Module. | Correctly connect the Safety Option Module. | – |
| | The Safety Option Module was disconnected. | – | Execute Fn014 (Reset Option Module Configuration Error) from the Digital Operator or SigmaWin+ and then turn the power supply to the SERVOPACK OFF and ON again. | *1 |
| | A failure occurred in the Safety Option Module. | – | Replace the Safety Option Module. | – |
| | A failure occurred in the SERVOPACK. | – | Replace the SERVOPACK. | – |

Continued on next page.

4.1 SERVOPACKs with Analog Voltage/Pulse Train References

4.1.3 Troubleshooting Alarms

Continued from previous page.

| Alarm Number: Alarm Name | Possible Cause | Confirmation | Correction | Reference |
|--|--|--|--|-----------|
| A.E72: Feedback Option Module Detection Failure | There is a faulty connection between the SERVOPACK and the Feedback Option Module. | Check the connection between the SERVOPACK and the Feedback Option Module. | Correctly connect the Feedback Option Module. | – |
| | The Feedback Option Module was disconnected. | – | Reset the Option Module configuration error and turn the power supply to the SERVOPACK OFF and ON again. | *1 |
| | A failure occurred in the Feedback Option Module. | – | Replace the Feedback Option Module. | – |
| | A failure occurred in the SERVOPACK. | – | Replace the SERVOPACK. | – |
| A.E74: Unsupported Safety Option Module | A failure occurred in the Safety Option Module. | – | Replace the Safety Option Module. | – |
| | An unsupported Safety Option Module was connected. | Refer to the catalog of the connected Safety Option Module. | Connect a compatible Safety Option Module. | – |
| A.Eb1: Safety Function Signal Input Timing Error | The delay between activation of the /HWBB1 and /HWBB2 input signals for the HWBB was ten second or longer. | Measure the time delay between the /HWBB1 and /HWBB2 signals. | The output signal circuits or devices for /HWBB1 and /HWBB2 or the SERVOPACK input signal circuits may be faulty. Alternatively, the input signal cables may be disconnected. Check to see if any of these items are faulty or have been disconnected. | – |
| | A failure occurred in the SERVOPACK. | – | Replace the SERVOPACK. | – |
| A.EC8: Gate Drive Error 1 (An error occurred in the gate drive circuit.) | A failure occurred in the SERVOPACK. | – | Turn the power supply to the SERVOPACK OFF and ON again. If an alarm still occurs, the SERVOPACK may be faulty. Replace the SERVOPACK. | – |
| A.EC9: Gate Drive Error 2 (An error occurred in the gate drive circuit.) | | | | |

Continued on next page.

Continued from previous page.

| Alarm Number: Alarm Name | Possible Cause | Confirmation | Correction | Reference |
|--|--|--|--|-----------|
| A.F10: Power Supply Line Open Phase (The voltage was low for more than one second for phase R, S, or T when the main power supply was ON.) | The three-phase power supply wiring is not correct. | Check the power sup- ply wiring. | Make sure that the power supply is correctly wired. | *1 |
| | The three-phase power supply is unbalanced. | Measure the voltage for each phase of the three-phase power sup- ply. | Balance the power sup- ply by changing phases. | – |
| | A single-phase power supply was input with- out specifying a sig- nal-phase AC power supply input (Pn00B = n.□1□□). | Check the power sup- ply and the parameter setting. | Match the parameter set- ting to the power supply. | *1 |
| | A failure occurred in the SERVOPACK. | – | Turn the power supply to the SERVOPACK OFF and ON again. If an alarm still occurs, the SERVOPACK may be faulty. Replace the SERVOPACK. | – |
| FL-1*6: System Alarm | A failure occurred in the SERVOPACK. | – | Turn the power supply to the SERVOPACK OFF and ON again. If an alarm still occurs, the SERVOPACK may be faulty. Replace the SERVOPACK. | – |
| FL-2*6: System Alarm | | | | |
| FL-3*6: System Alarm | | | | |
| FL-4*6: System Alarm | | | | |
| FL-5*6: System Alarm | | | | |
| FL-6*6: System Alarm | | | | |
| CPF00: Digital Operator Communications Error 1 | There is a faulty con- nection between the Digital Operator and the SERVOPACK. | Check the connector contact. | Disconnect the connec- tor and insert it again. Or, replace the cable. | – |
| | A malfunction was caused by noise. | – | Keep the Digital Operator or the cable away from sources of noise. | – |
| CPF01: Digital Operator Communications Error 2 | A failure occurred in the Digital Operator. | – | Disconnect the Digital Operator and then con- nect it again. If an alarm still occurs, the Digital Operator may be faulty. Replace the Digital Oper- ator. | – |
| | A failure occurred in the SERVOPACK. | – | Turn the power supply to the SERVOPACK OFF and ON again. If an alarm still occurs, the SERVOPACK may be faulty. Replace the SERVOPACK. | – |

4.1.4 Warning Displays

*1. Refer to the following manual for details.

 Σ -7-Series Σ -7S SERVOPACK with Analog Voltage/Pulse Train References Product Manual (Manual No.: SIEP S800001 26)

*2. Detection Conditions

• Rotary Servomotor
If either of the following conditions is detected, an alarm will occur.

$$\bullet \text{ Pn533 [min}^{-1}\text{]} \times \frac{\text{Encoder resolution}}{6 \times 10^5} \leq \frac{\text{Pn20E}}{\text{Pn210}}$$

$$\bullet \text{ Maximum motor speed [min}^{-1}\text{]} \times \frac{\text{Encoder resolution}}{\text{Approx. } 3.66 \times 10^{12}} \geq \frac{\text{Pn20E}}{\text{Pn210}}$$

• Linear Servomotor
If either of the following conditions is detected, an alarm will occur.

$$\bullet \frac{\text{Pn585 [mm/s]}}{\text{Linear encoder pitch [\mu m]}} \times \frac{\text{Resolution of Serial Converter Unit}}{10} \leq \frac{\text{Pn20E}}{\text{Pn210}}$$

$$\bullet \frac{\text{Pn385 [100 mm/s]}}{\text{Linear encoder pitch [\mu m]}} \times \frac{\text{Resolution of Serial Converter Unit}}{\text{Approx. } 6.10 \times 10^5} \geq \frac{\text{Pn20E}}{\text{Pn210}}$$

*3. Detection Conditions

• Rotary Servomotor
If either of the following conditions is detected, an alarm will occur.

$$\bullet \text{ Rated motor speed [min}^{-1}\text{]} \times 1/3 \times \frac{\text{Encoder resolution}}{6 \times 10^5} \leq \frac{\text{Pn20E}}{\text{Pn210}}$$

$$\bullet \text{ Maximum motor speed [min}^{-1}\text{]} \times \frac{\text{Encoder resolution}}{\text{Approx. } 3.66 \times 10^{12}} \geq \frac{\text{Pn20E}}{\text{Pn210}}$$

• Linear Servomotor
If either of the following conditions is detected, an alarm will occur.

$$\bullet \frac{\text{Rated motor speed [mm/s]} \times 1/3}{\text{Linear encoder pitch [\mu m]}} \times \frac{\text{Resolution of Serial Converter Unit}}{10} \leq \frac{\text{Pn20E}}{\text{Pn210}}$$

$$\bullet \frac{\text{Pn385 [100 mm/s]}}{\text{Linear encoder pitch [\mu m]}} \times \frac{\text{Resolution of Serial Converter Unit}}{\text{Approx. } 6.10 \times 10^5} \geq \frac{\text{Pn20E}}{\text{Pn210}}$$

*4. Refer to the following manual for details.

 Σ -7-Series Peripheral Device Selection Manual (Manual No.: SIEP S800001 32)

*5. The SERVOPACK will fail if the External Regenerative Resistor or Regenerative Resistor Unit is connected while the jumper is connected between the B2 and B3 terminals.

*6. These alarms are not stored in the alarm history. They are only displayed on the panel display.

4.1.4 Warning Displays

If a warning occurs in the SERVOPACK, a warning number will be displayed on the panel display. Warnings are displayed to warn you before an alarm occurs.

4.1.5 List of Warnings

The list of warnings gives the warning name, warning meaning, and warning code output in order of the warning numbers.

| Warning Number | Warning Name | Meaning | Warning Code Output | | |
|----------------|--|--|---------------------|------|------|
| | | | ALO1 | ALO2 | ALO3 |
| A.900 | Position Deviation Overflow | The position deviation exceeded the percentage set with the following formula: (Pn520 × Pn51E/100) | H | H | H |
| A.901 | Position Deviation Overflow Alarm at Servo ON | The position deviation when the servo was turned ON exceeded the percentage set with the following formula: (Pn526 × Pn528/100) | H | H | H |
| A.910 | Overload | This warning occurs before an overload alarm (A.710 or A.720) occurs. If the warning is ignored and operation is continued, an alarm may occur. | L | H | H |
| A.911 | Vibration | Abnormal vibration was detected during motor operation. The detection level is the same as A.520. Set whether to output an alarm or a warning by setting Pn310 (Vibration Detection Selections). | L | H | H |
| A.912 | Internal Temperature Warning 1 (Control Board Temperature Error) | The surrounding temperature of the control PCB is abnormal. | H | L | H |
| A.913 | Internal Temperature Warning 2 (Power Board Temperature Error) | The surrounding temperature of the power PCB is abnormal. | H | L | H |
| A.920 | Regenerative Overload | This warning occurs before an A.320 alarm (Regenerative Overload) occurs. If the warning is ignored and operation is continued, an alarm may occur. | H | L | H |
| A.921 | Dynamic Brake Overload | This warning occurs before an A.731 alarm (Dynamic Brake Overload) occurs. If the warning is ignored and operation is continued, an alarm may occur. | H | L | H |
| A.923 | SERVOPACK Built-in Fan Stopped | The fan inside the SERVOPACK stopped. | H | L | H |
| A.930 | Absolute Encoder Battery Error | This warning occurs when the voltage of absolute encoder's battery is low. | L | L | H |
| A.93B | Overheat Warning | The input voltage (temperature) for the overheat protection input (TH) signal exceeded the setting of Pn61C (Overheat Warning Level). | L | L | H |
| A.941 | Change of Parameters Requires Restart | Parameters have been changed that require the power supply to be turned OFF and ON again. | H | H | L |
| A.942 | Speed Ripple Compensation Information Disagreement | The speed ripple compensation information stored in the encoder does not agree with the speed ripple compensation information stored in the SERVOPACK. | H | H | L |
| A.971 | Undervoltage | This warning occurs before an A.410 alarm (Undervoltage) occurs. If the warning is ignored and operation is continued, an alarm may occur. | L | L | L |
| A.9A0 | Overtravel | Overtravel was detected while the servo was ON. | H | L | L |
| A.9b0 | Preventative Maintenance Warning | One of the consumable parts has reached the end of its service life. | H | L | H |

4.1 SERVOPACKs with Analog Voltage/Pulse Train References

4.1.6 Troubleshooting Warnings

- Note: 1. A warning code is not output unless you set Pn001 to n.1□□□ (Output both alarm codes and warning codes).
2. Use Pn008 = n.□X□□ (Warning Detection Selection) to control warning detection. However, the following warnings are not affected by the setting of Pn008 = n.□X□□ and other parameter settings are required in addition to Pn008 = n.□X□□.

| Warning | Parameters That Must Be Set to Select Warning Detection |
|---------|---|
| A.911 | Pn310 = n.□□□X (Vibration Detection Selection) |
| A.923 | – (Not affected by the setting of Pn008 = n.□X□□.) |
| A.930 | Pn008 = n.□□□X (Low Battery Voltage Alarm/Warning Selection) |
| A.942 | Pn423 = n.□□X□ (Speed Ripple Compensation Information Disagreement Warning Detection Selection) |
| A.971 | Pn008 = n.□□X□ (Function Selection for Undervoltage) (Not affected by the setting of Pn008 = n.□X□□.) |
| A.9A0 | Pn00D = n.X□□□ (Overtravel Warning Detection Selection) (Not affected by the setting of Pn008 = n.□X□□.) |
| A.9b0 | Pn00F = n.□□□X (Preventative Maintenance Warning Selection) |

4.1.6 Troubleshooting Warnings

The causes of and corrections for the warnings are given in the following table. Contact your Yaskawa representative if you cannot solve a problem with the correction given in the table.

| Warning Number: Warning Name | Possible Cause | Confirmation | Correction | Reference |
|---|--|---|--|-----------|
| A.900: Position Deviation Overflow | The Servomotor U, V, and W wiring is not correct. | Check the wiring of the Servomotor's Main Circuit Cables. | Make sure that there are no faulty connections in the wiring for the Servomotor and encoder. | – |
| | A SERVOPACK gain is too low. | Check the SERVO-PACK gains. | Increase the servo gain, e.g., by using autotuning without a host reference. | * |
| | The frequency of the position reference pulse is too high. | Reduce the reference pulse frequency and try operating the SERVO-PACK. | Reduce the position reference pulse frequency or the reference acceleration rate, or reconsider the electronic gear ratio. | * |
| | The acceleration of the position reference is too high. | Reduce the reference acceleration and try operating the SERVO-PACK. | Apply smoothing, i.e., by using Pn216 (Position Reference Acceleration/ Deceleration Time Constant). | * |
| | The excessive position deviation alarm level (Pn520 × Pn51E/100) is too low for the operating conditions. | Check excessive position deviation alarm level (Pn520 × Pn51E/100) to see if it is set to an appropriate value. | Optimize the settings of Pn520 and Pn51E. | * |
| | A failure occurred in the SERVO-PACK. | – | Turn the power supply to the SERVOPACK OFF and ON again. If an alarm still occurs, the SERVOPACK may be faulty. Replace the SERVOPACK. | – |
| A.901: Position Deviation Overflow Alarm at Servo ON | The position deviation when the servo was turned ON exceeded the percentage set with the following formula: (Pn526 × Pn528/100) | – | Set the position deviation to be cleared while the servo is OFF. Optimize the setting of Pn528 (Position Deviation Overflow Warning Level at Servo ON). | * |

Continued on next page.

Continued from previous page.

| Warning Number: Warning Name | Possible Cause | Confirmation | Correction | Reference |
|--|--|--|--|-----------|
| A.910: Overload (warning before an A.710 or A.720 alarm occurs) | The wiring is not correct or there is a faulty connection in the motor or encoder wiring. | Check the wiring. | Make sure that the Servomotor and encoder are correctly wired. | – |
| | Operation was performed that exceeded the overload protection characteristics. | Check the motor overload characteristics and Run command. | Reconsider the load and operating conditions. Or, increase the motor capacity. | – |
| | An excessive load was applied during operation because the Servomotor was not driven because of mechanical problems. | Check the operation reference and motor speed. | Remove the mechanical problem. | – |
| | The overload warning level (Pn52B) is not suitable. | Check that the overload warning level (Pn52B) is suitable. | Set a suitable overload warning level (Pn52B). | * |
| | A failure occurred in the SERVOPACK. | – | The SERVOPACK may be faulty. Replace the SERVOPACK. | – |
| A.911: Vibration | Abnormal vibration was detected during motor operation. | Check for abnormal motor noise, and check the speed and torque waveforms during operation. | Reduce the motor speed. Or, reduce the servo gain with custom tuning. | * |
| | The setting of Pn103 (Moment of Inertia Ratio) is greater than the actual moment of inertia or was greatly changed. | Check the moment of inertia ratio or mass ratio. | Set Pn103 (Moment of Inertia Ratio) to an appropriate value. | * |
| | The vibration detection level (Pn312 or Pn384) is not suitable. | Check that the vibration detection level (Pn312 or Pn384) is suitable. | Set a suitable vibration detection level (Pn312 or Pn384). | * |

Continued on next page.

4.1 SERVOPACKs with Analog Voltage/Pulse Train References

4.1.6 Troubleshooting Warnings

Continued from previous page.

| Warning Number: Warning Name | Possible Cause | Confirmation | Correction | Reference |
|--|--|---|--|-----------|
| A.912: Internal Temperature Warning 1 (Control Board Temperature Error) | The surrounding temperature is too high. | Check the surrounding temperature using a thermometer. Or, check the operating status with the SERVOPACK installation environment monitor. | Decrease the surrounding temperature by improving the SERVOPACK installation conditions. | * |
| | An overload alarm was reset by turning OFF the power supply too many times. | Check the alarm display to see if there is an overload alarm. | Change the method for resetting the alarm. | - |
| | There was an excessive load or operation was performed that exceeded the regenerative processing capacity. | Use the accumulated load ratio to check the load during operation, and use the regenerative load ratio to check the regenerative processing capacity. | Reconsider the load and operating conditions. | - |
| | The SERVOPACK installation orientation is not correct or there is insufficient space around the SERVOPACK. | Check the SERVOPACK installation conditions. | Install the SERVOPACK according to specifications. | * |
| | A failure occurred in the SERVOPACK. | - | The SERVOPACK may be faulty. Replace the SERVOPACK. | - |
| A.913: Internal Temperature Warning 2 (Power Board Temperature Error) | The surrounding temperature is too high. | Check the surrounding temperature using a thermometer. Or, check the operating status with the SERVOPACK installation environment monitor. | Decrease the surrounding temperature by improving the SERVOPACK installation conditions. | * |
| | An overload alarm was reset by turning OFF the power supply too many times. | Check the alarm display to see if there is an overload alarm. | Change the method for resetting the alarm. | - |
| | There was an excessive load or operation was performed that exceeded the regenerative processing capacity. | Use the accumulated load ratio to check the load during operation, and use the regenerative load ratio to check the regenerative processing capacity. | Reconsider the load and operating conditions. | - |
| | The SERVOPACK installation orientation is not correct or there is insufficient space around the SERVOPACK. | Check the SERVOPACK installation conditions. | Install the SERVOPACK according to specifications. | * |
| | A failure occurred in the SERVOPACK. | - | The SERVOPACK may be faulty. Replace the SERVOPACK. | - |

Continued on next page.

Continued from previous page.

| Warning Number: Warning Name | Possible Cause | Confirmation | Correction | Reference |
|--|---|--|---|-----------|
| A.920: Regenerative Overload (warning before an A.320 alarm occurs) | The power supply voltage exceeded the specified range. | Measure the power supply voltage. | Set the power supply voltage within the specified range. | - |
| | There is insufficient external regenerative resistance, regenerative resistor capacity, or SERVOPACK capacity, or there has been a continuous regeneration state. | Check the operating conditions or the capacity using the SigmaJunmaSize+ Capacity Selection Software or another means. | Change the regenerative resistance value, regenerative resistance capacity, or SERVOPACK capacity. Reconsider the operating conditions using the SigmaJunmaSize+ Capacity Selection Software or other means. | - |
| | There was a continuous regeneration state because a negative load was continuously applied. | Check the load applied to the Servomotor during operation. | Reconsider the system including the servo, machine, and operating conditions. | - |
| A.921: Dynamic Brake Overload (warning before an A.731 alarm occurs) | The Servomotor was rotated by an external force. | Check the operation status. | Implement measures to ensure that the motor will not be rotated by an external force. | - |
| | When the Servomotor was stopped with the dynamic brake, the rotational or linear kinetic energy exceeded the capacity of the dynamic brake resistor. | Check the power consumed by the DB resistor to see how frequently the DB is being used. | Reconsider the following: <ul style="list-style-type: none"> • Reduce the Servomotor command speed. • Decrease the moment of inertia or mass. • Reduce the frequency of stopping with the dynamic brake. | - |
| | A failure occurred in the SERVOPACK. | - | The SERVOPACK may be faulty. Replace the SERVOPACK. | - |
| A.923: SERVOPACK Built-in Fan Stopped | The fan inside the SERVOPACK stopped. | Check for foreign matter inside the SERVOPACK. | Remove foreign matter from the SERVOPACK. If an alarm still occurs, the SERVOPACK may be faulty. Replace the SERVOPACK. | - |
| A.930: Absolute Encoder Battery Error (The absolute encoder battery voltage was lower than the specified level.) (Detected only when an absolute encoder is connected.) | The battery connection is faulty or a battery is not connected. | Check the battery connection. | Correct the battery connection. | * |
| | The battery voltage is lower than the specified value (2.7 V). | Measure the battery voltage. | Replace the battery. | * |
| | A failure occurred in the SERVOPACK. | - | The SERVOPACK may be faulty. Replace the SERVOPACK. | - |

Continued on next page.

4.1 SERVOPACKs with Analog Voltage/Pulse Train References

4.1.6 Troubleshooting Warnings

Continued from previous page.

| Warning Number: Warning Name | Possible Cause | Confirmation | Correction | Reference |
|--|--|--|---|-----------|
| A.93B: Overheat Warning | The surrounding temperature is too high. | Check the surrounding temperature using a thermometer. | Lower the surrounding temperature by improving the installation conditions of the Linear Servomotor or the machine. | - |
| | Operation was performed under an excessive load. | Use the accumulated load ratio to check the load during operation. | Reconsider the load and operating conditions. | - |
| | A failure occurred in the SERVO-PACK. | - | The SERVOPACK may be faulty. Replace the SERVO-PACK. | - |
| | The temperature detection circuit in the Linear Servomotor is faulty or the sensor attached to the machine is faulty. | - | The temperature detection circuit in the Linear Servomotor may be faulty or the sensor attached to the machine may be faulty. Replace the Linear Servomotor or repair the sensor attached to the machine. | - |
| A.941: Change of Parameters Requires Restart | Parameters have been changed that require the power supply to be turned OFF and ON again. | - | Turn the power supply to the SERVOPACK OFF and ON again. | - |
| A.942: Speed Ripple Compensation Information Disagreement | The speed ripple compensation information stored in the encoder does not agree with the speed ripple compensation information stored in the SERVOPACK. | - | Reset the speed ripple compensation value on the SigmaWin+. | * |
| | | - | Set Pn423 to n.□□1□ (Do not detect A.942 alarms). However, changing the setting may increase the speed ripple. | - |
| | | - | Set Pn423 to n.□□□0 (Disable speed ripple compensation). However, changing the setting may increase the speed ripple. | - |
| A.971: Undervoltage | For a 200-V SERVOPACK, the AC power supply voltage dropped below 140 V. | Measure the power supply voltage. | Set the power supply voltage within the specified range. | - |
| | For a 100-V SERVOPACK, the AC power supply voltage dropped below 60 V. | Measure the power supply voltage. | Set the power supply voltage within the specified range. | - |
| | The power supply voltage dropped during operation. | Measure the power supply voltage. | Increase the power supply capacity. | - |
| | A momentary power interruption occurred. | Measure the power supply voltage. | If you have changed the setting of Pn509 (Momentary Power Interruption Hold Time), decrease the setting. | * |
| | The SERVOPACK fuse is blown out. | - | Replace the SERVOPACK and connect a reactor. | * |
| | A failure occurred in the SERVO-PACK. | - | The SERVOPACK may be faulty. Replace the SERVO-PACK. | - |

Continued on next page.

Continued from previous page.

| Warning Number: Warning Name | Possible Cause | Confirmation | Correction | Reference |
|---|--|---|---|-----------|
| A.9A0: Overtravel (Overtravel status was detected.) | Overtravel was detected while the servo was ON. | Check the status of the overtravel signals on the input signal monitor. | Even if an overtravel signal is not shown by the input signal monitor, momentary overtravel may have been detected. Take the following precautions. <ul style="list-style-type: none"> • Do not specify movements that would cause overtravel from the host controller. • Check the wiring of the overtravel signals. • Implement countermeasures against noise. | * |
| A.9b0: Preventative Maintenance Warning | One of the consumable parts has reached the end of its service life. | – | Replace the part. Contact your Yaskawa representative for replacement. | * |

* Refer to the following manual for details.

 Σ -7-Series Σ -7S SERVOPACK with Analog Voltage/Pulse Train References Product Manual
(Manual No.: SIEP S800001 26)

4.1.7 Troubleshooting Based on the Operation and Conditions of the Servomotor

This section provides troubleshooting based on the operation and conditions of the Servomotor, including causes and corrections.

| Problem | Possible Cause | Confirmation | Correction | Reference |
|---------------------------|---|--|--|-----------|
| Servomotor Does Not Start | The control power supply is not turned ON. | Measure the voltage between control power supply terminals. | Turn OFF the power supply to the servo system. Correct the wiring so that the control power supply is turned ON. | - |
| | The main circuit power supply is not turned ON. | Measure the voltage between the main circuit power input terminals. | Turn OFF the power supply to the servo system. Correct the wiring so that the main circuit power supply is turned ON. | - |
| | The I/O signal connector (CN1) pins are not wired correctly or are disconnected. | Turn OFF the power supply to the servo system. Check the wiring condition of the I/O signal connector (CN1) pins. | Correct the wiring of the I/O signal connector (CN1) pins. | * |
| | The wiring for the Servomotor Main Circuit Cables or Encoder Cable is disconnected. | Check the wiring conditions. | Turn OFF the power supply to the servo system. Wire the cable correctly. | - |
| | There is an overload on the Servomotor. | Operate the Servomotor with no load and check the load status. | Turn OFF the power supply to the servo system. Reduce the load or replace the Servomotor with a Servomotor with a larger capacity. | - |
| | The type of encoder that is being used does not agree with the setting of Pn002 = n.□X□□ (Encoder Usage). | Check the type of the encoder that is being used and the setting of Pn002 = n.□X□□. | Set Pn002 = n.□X□□ according to the type of the encoder that is being used. | * |
| | No speed or position reference is input. | Turn OFF the power supply to the servo system. Check the allocation status of the input signals. | Allocate an input signal so that the speed and position references are input correctly. | * |
| | There is a mistake in the input signal allocations (Pn50A to Pn50D, Pn515, and Pn516). | Check the input signal allocations (Pn50A to Pn50D, Pn515, and Pn516). | Correctly allocate the input signals (Pn50A to Pn50D, Pn515, and Pn516). | * |
| | The /S-ON (Servo ON) signal is OFF. | Check the settings of Pn50A = n.□□□X (Input Signal Allocation Mode) and Pn50A = n.□□X□ (/S-ON (Servo ON) Signal Allocation). | Set Pn50A = n.□□XX correctly and turn ON the /S-ON signal. | * |
| | The function setting of the /P-CON (Proportional Control) signal is not correct. | Check the setting of Pn000 = n.□□X□ (Control Method Selection). | Set the parameter to match the application. | * |
| The SEN input is OFF. | Check the ON/OFF status of the SEN input. | If you are using an absolute encoder, turn ON the SEN signal. | * | |

Continued on next page.

4.1.7 Troubleshooting Based on the Operation and Conditions of the Servomotor

Continued from previous page.

| Problem | Possible Cause | Confirmation | Correction | Reference |
|---------------------------|---|---|--|--------------------------------|
| Servomotor Does Not Start | The reference pulse mode selection is not correct. | Check the setting of Pn200 =n.□□□X (Reference Pulse Form) and the reference pulse form. | Set Pn200 =n.□□□X so that it agrees with the reference pulse form. | * |
| | Speed control: The speed reference input is not appropriate. | Check between the speed reference input (V-REF) and signal ground (SG) to see if the control method and the input agree. | Correctly set the control method and input method. | * |
| | Torque control: The torque reference input is not appropriate. | Check between the torque reference input (T-REF) and signal ground (SG) to see if the control method and the input agree. | Correctly set the control method and input method. | * |
| | Position control: The reference pulse input is not appropriate. | Check the setting of Pn200 =n.□□□X (Reference Pulse Form) and the sign and pulse signals. | Correctly set the control method and input method. | * |
| | The /CLR (Position Deviation Clear) input signal has not been turned OFF. | Check the /CLR signal (CN1-14 and CN1-15). | Turn OFF the /CLR signal. | * |
| | The P-OT (Forward Drive Prohibit) or N-OT (Reverse Drive Prohibit) signal is still OFF. | Check the P-OT and N-OT signals. | Turn ON the P-OT and N-OT signals. | * |
| | The safety input signals (/HWBB1 or /HWBB2) were not turned ON. | Check the /HWBB1 and /HWBB2 input signals. | Turn ON the /HWBB1 and /HWBB2 input signals. If you are not using the safety function, connect the Safety Jumper Connector (provided as an accessory) to CN8. | * |
| | The FSTP (Forced Stop Input) signal is still OFF. | Check the FSTP signal. | <ul style="list-style-type: none"> Turn ON the FSTP signal. If you will not use the function to force the motor to stop, set Pn516 = n.□□□X (FSTP (Forced Stop Input) Signal Allocation) to disable the signal. | * |
| | A failure occurred in the SERVOPACK. | — | Turn OFF the power supply to the servo system. Replace the SERVOPACK. | — |
| | The polarity detection was not executed. | | Check the setting of Pn080 =n.□□□X (Polarity Sensor Selection). | Correct the parameter setting. |
| | | Check the /S-ON (Servo ON) or /P-DET (Polarity Detection) input signal. | <ul style="list-style-type: none"> If you are using an incremental linear encoder, turn ON the /S-ON or /P-DET signal. If you are using an absolute linear encoder, turn OFF the external /S-ON signal and execute polarity detection. | * |

Continued on next page.

4.1 SERVOPACKs with Analog Voltage/Pulse Train References

4.1.7 Troubleshooting Based on the Operation and Conditions of the Servomotor

Continued from previous page.

| Problem | Possible Cause | Confirmation | Correction | Reference |
|--|--|--|--|-----------|
| Servomotor Moves Instantaneously, and Then Stops | There is a mistake in the Servomotor wiring. | Turn OFF the power supply to the servo system. Check the wiring. | Wire the Servomotor correctly. | - |
| | There is a mistake in the wiring of the encoder or Serial Converter Unit. | Turn OFF the power supply to the servo system. Check the wiring. | Wire the Serial Converter Unit correctly. | - |
| | There is a mistake in the linear encoder wiring. | Turn OFF the power supply to the servo system. Check the wiring. | Wire the cable correctly. | - |
| | The setting of Pn282 (Linear Encoder Scale Pitch) is not correct. | Check the setting of Pn282. | Correct the setting of Pn282. | * |
| | The count-up direction of the linear encoder does not match the forward direction of the Moving Coil in the motor. | Check the directions. | Change the setting of Pn080 = n.□□X□ (Motor Phase Sequence Selection). Place the linear encoder and motor in the same direction. | * |
| | Polarity detection was not performed correctly. | Check to see if electrical angle 2 (electrical angle from polarity origin) at any position is between $\pm 10^\circ$. | Correct the settings for the polarity detection-related parameters. | - |
| Servomotor Speed Is Unstable | There is a faulty connection in the Servomotor wiring. | The connector connections for the power line (U, V, and W phases) and the encoder or Serial Converter Unit may be unstable. Turn OFF the power supply to the servo system. Check the wiring. | Tighten any loose terminals or connectors and correct the wiring. | - |

Continued on next page.

Continued from previous page.

| Problem | Possible Cause | Confirmation | Correction | Reference |
|--|--|--|--|-----------|
| Servomotor Moves without a Reference Input | Speed control: The speed reference input is not appropriate. | Check between the speed reference input (V-REF) and signal ground (SG) to see if the control method and the input agree. | Correctly set the control method and input method. | * |
| | Torque control: The torque reference input is not appropriate. | Check between the torque reference input (T-REF) and signal ground (SG) to see if the control method and the input agree. | Correctly set the control method and input method. | * |
| | The speed reference offset is not correct. | The SERVOPACK offset is adjusted incorrectly. | Adjust the SERVOPACK offset. | * |
| | Position control: The reference pulse input is not appropriate. | Check the setting of Pn200 = n.□□□X (Reference Pulse Form) and the sign and pulse signals. | Correctly set the control method and input method. | - |
| | A failure occurred in the SERVOPACK. | - | Turn OFF the power supply to the servo system. Replace the SERVOPACK. | - |
| | The count-up direction of the linear encoder does not match the forward direction of the Moving Coil in the motor. | Check the directions. | Change the setting of Pn080 = n.□□□□ (Motor Phase Sequence Selection). Match the linear encoder direction and Servomotor direction. | * |
| | Polarity detection was not performed correctly. | Check to see if electrical angle 2 (electrical angle from polarity origin) at any position is between $\pm 10^\circ$. | Correct the settings for the polarity detection-related parameters. | - |
| Dynamic Brake Does Not Operate | The setting of Pn001 = n.□□□X (Motor Stopping Method for Servo OFF and Group 1 Alarms) is not suitable. | Check the setting of Pn001 = n.□□□X. | Set Pn001 = n.□□□X correctly. | - |
| | The dynamic brake resistor is disconnected. | Check the moment of inertia, motor speed, and dynamic brake frequency of use. If the moment of inertia, motor speed, or dynamic brake frequency of use is excessive, the dynamic brake resistance may be disconnected. | Turn OFF the power supply to the servo system. Replace the SERVOPACK. To prevent disconnection, reduce the load. | - |
| | There was a failure in the dynamic brake drive circuit. | - | There is a defective component in the dynamic brake circuit. Turn OFF the power supply to the servo system. Replace the SERVOPACK. | - |

Continued on next page.

4.1 SERVOPACKs with Analog Voltage/Pulse Train References

4.1.7 Troubleshooting Based on the Operation and Conditions of the Servomotor

Continued from previous page.

| Problem | Possible Cause | Confirmation | Correction | Reference |
|--------------------------------|---|--|---|-----------|
| Abnormal Noise from Servomotor | The Servomotor vibrated considerably while performing the tuning-less function with the default settings. | Check the waveform of the motor speed. | Reduce the load so that the moment of inertia ratio or mass ratio is within the allowable value, or increase the load level or reduce the rigidity level in the tuning-less level settings. If the situation is not improved, disable the tuning-less function (i.e., set Pn170 to n.□□□0) and execute autotuning either with or without a host reference. | * |
| | The machine mounting is not secure. | Turn OFF the power supply to the servo system. Check to see if there are any loose mounting screws. | Tighten the mounting screws. | - |
| | | Turn OFF the power supply to the servo system. Check to see if there is misalignment in the coupling. | Align the coupling. | - |
| | | Turn OFF the power supply to the servo system. Check to see if the coupling is balanced. | Balance the coupling. | - |
| | The bearings are defective. | Turn OFF the power supply to the servo system. Check for noise and vibration around the bearings. | Replace the Servomotor. | - |
| | There is a vibration source at the driven machine. | Turn OFF the power supply to the servo system. Check for any foreign matter, damage, or deformation in the machine's moving parts. | Consult with the machine manufacturer. | - |
| | Noise interference occurred because of incorrect I/O signal cable specifications. | Turn OFF the power supply to the servo system. Check the I/O signal cables to see if they satisfy specifications. Use shielded twisted-pair wire cables or screened twisted-pair cables with conductors of at least 0.12 mm ² . | Use cables that satisfy the specifications. | - |
| | Noise interference occurred because an I/O signal cable is too long. | Turn OFF the power supply to the servo system. Check the lengths of the I/O signal cables. | The I/O signal cables must be no longer than 3 m. | - |

Continued on next page.

Continued from previous page.

| Problem | Possible Cause | Confirmation | Correction | Reference |
|--------------------------------|---|--|--|-----------|
| Abnormal Noise from Servomotor | Noise interference occurred because of incorrect Encoder Cable specifications. | Turn OFF the power supply to the servo system. Make sure that the rotary or Linear Encoder Cable satisfies the specifications. Use a shielded twisted-pair wire cable or a screened twisted-pair cable with a conductors of at least 0.12 mm ² . | Use cables that satisfy the specifications. | - |
| | Noise interference occurred because the Encoder Cable is too long. | Turn OFF the power supply to the servo system. Check the length of the Encoder Cable. | <ul style="list-style-type: none"> Rotary Servomotors: The Encoder Cable length must be 50 m max. Linear Servomotors: Make sure that the Serial Converter Unit cable is no longer than 20 m and that the Linear Encoder Cable and the Sensor Cable are no longer than 15 m each. | - |
| | Noise interference occurred because the Encoder Cable is damaged. | Turn OFF the power supply to the servo system. Check the Encoder Cable to see if it is pinched or the sheath is damaged. | Replace the Encoder Cable and correct the cable installation environment. | - |
| | The Encoder Cable was subjected to excessive noise interference. | Turn OFF the power supply to the servo system. Check to see if the Encoder Cable is bundled with a high-current line or installed near a high-current line. | Correct the cable layout so that no surge is applied by high-current lines. | - |
| | There is variation in the FG potential because of the influence of machines on the Servomotor side, such as a welder. | Turn OFF the power supply to the servo system. Check to see if the machines are correctly grounded. | Properly ground the machines to separate them from the FG of the encoder. | - |
| | There is a SERVOPACK pulse counting error due to noise. | Check to see if there is noise interference on the signal line from the encoder. | Turn OFF the power supply to the servo system. Implement counter-measures against noise for the encoder wiring. | - |
| | The encoder was subjected to excessive vibration or shock. | Turn OFF the power supply to the servo system. Check to see if vibration from the machine occurred. Check the Servomotor installation (mounting surface precision, securing state, and alignment). Check the linear encoder installation (mounting surface precision and securing method). | Reduce machine vibration. Improve the mounting state of the Servomotor or linear encoder. | - |
| | A failure occurred in the encoder. | - | Turn OFF the power supply to the servo system. Replace the Servomotor. | - |

Continued on next page.

4.1 SERVOPACKs with Analog Voltage/Pulse Train References

4.1.7 Troubleshooting Based on the Operation and Conditions of the Servomotor

Continued from previous page.

| Problem | Possible Cause | Confirmation | Correction | Reference |
|---|--|---|--|-----------|
| Abnormal Noise from Servomotor | A failure occurred in the Serial Converter Unit. | – | Turn OFF the power supply to the servo system. Replace the Serial Converter Unit. | – |
| | A failure occurred in the linear encoder. | – | Turn OFF the power supply to the servo system. Replace the linear encoder. | – |
| Servomotor Vibrates at Frequency of Approx. 200 Hz to 400 Hz. | The servo gains are not balanced. | Check to see if the servo gains have been correctly tuned. | Perform autotuning without a host reference. | * |
| | The setting of Pn100 (Speed Loop Gain) is too high. | Check the setting of Pn100. The default setting is Kv = 40.0 Hz. | Set Pn100 to an appropriate value. | – |
| | The setting of Pn102 (Position Loop Gain) is too high. | Check the setting of Pn102. The default setting is Kp = 40.0/s. | Set Pn102 to an appropriate value. | – |
| | The setting of Pn101 (Speed Loop Integral Time Constant) is not appropriate. | Check the setting of Pn101. The default setting is Ti = 20.0 ms. | Set Pn101 to an appropriate value. | – |
| | The setting of Pn103 (Moment of Inertia Ratio or Mass Ratio) is not appropriate. | Check the setting of Pn103. | Set Pn103 to an appropriate value. | – |
| Large Motor Speed Overshoot on Starting and Stopping | The servo gains are not balanced. | Check to see if the servo gains have been correctly tuned. | Perform autotuning without a host reference. | * |
| | The setting of Pn100 (Speed Loop Gain) is too high. | Check the setting of Pn100. The default setting is Kv = 40.0 Hz. | Set Pn100 to an appropriate value. | – |
| | The setting of Pn102 (Position Loop Gain) is too high. | Check the setting of Pn102. The default setting is Kp = 40.0/s. | Set Pn102 to an appropriate value. | – |
| | The setting of Pn101 (Speed Loop Integral Time Constant) is not appropriate. | Check the setting of Pn101. The default setting is Ti = 20.0 ms. | Set Pn101 to an appropriate value. | – |
| | The setting of Pn103 (Moment of Inertia Ratio or Mass Ratio) is not appropriate. | Check the setting of Pn103. | Set Pn103 to an appropriate value. | – |
| | The torque reference is saturated. | Check the waveform of the torque reference. | Use the mode switch. | – |
| | The force limits (Pn483 and Pn484) are set to the default values. | The default values of the force limits and Pn483 = 30% and Pn484 = 30%. | Set Pn483 and Pn484 to appropriate values. | * |

Continued on next page.

4.1.7 Troubleshooting Based on the Operation and Conditions of the Servomotor

Continued from previous page.

| Problem | Possible Cause | Confirmation | Correction | Reference |
|--|---|--|--|-----------|
| Absolute Encoder Position Deviation Error (The position that was saved in the host controller when the power was turned OFF is different from the position when the power was next turned ON.) | Noise interference occurred because of incorrect Encoder Cable specifications. | Turn OFF the power supply to the servo system. Check the Encoder Cable to see if it satisfies specifications. Use a shielded twisted-pair wire cable or a screened twisted-pair cable with conductors of at least 0.12 mm ² . | Use cables that satisfy the specifications. | - |
| | Noise interference occurred because the Encoder Cable is too long. | Turn OFF the power supply to the servo system. Check the length of the Encoder Cable. | <ul style="list-style-type: none"> Rotary Servomotors: The Encoder Cable length must be 50 m max. Linear Servomotors: Make sure that the Serial Converter Unit cable is no longer than 20 m and that the Linear Encoder Cable and the Sensor Cable are no longer than 15 m each. | - |
| | Noise interference occurred because the Encoder Cable is damaged. | Turn OFF the power supply to the servo system. Check the Encoder Cable to see if it is pinched or the sheath is damaged. | Replace the Encoder Cable and correct the cable installation environment. | - |
| | The Encoder Cable was subjected to excessive noise interference. | Turn OFF the power supply to the servo system. Check to see if the Encoder Cable is bundled with a high-current line or installed near a high-current line. | Correct the cable layout so that no surge is applied by high-current lines. | - |
| | There is variation in the FG potential because of the influence of machines on the Servomotor side, such as a welder. | Turn OFF the power supply to the servo system. Check to see if the machines are correctly grounded. | Properly ground the machines to separate them from the FG of the encoder. | - |
| | There is a SERVOPACK pulse counting error due to noise. | Turn OFF the power supply to the servo system. Check to see if there is noise interference on the I/O signal line from the encoder or Serial Converter Unit. | Implement countermeasures against noise for the encoder or Serial Converter Unit wiring. | - |
| | The encoder was subjected to excessive vibration or shock. | Turn OFF the power supply to the servo system. Check to see if vibration from the machine occurred. Check the Servomotor installation (mounting surface precision, securing state, and alignment). Check the linear encoder installation (mounting surface precision and securing method). | Reduce machine vibration. Improve the mounting state of the Servomotor or linear encoder. | - |
| | A failure occurred in the encoder. | - | Turn OFF the power supply to the servo system. Replace the Servomotor or linear encoder. | - |

Continued on next page.

4.1 SERVOPACKs with Analog Voltage/Pulse Train References

4.1.7 Troubleshooting Based on the Operation and Conditions of the Servomotor

Continued from previous page.

| Problem | Possible Cause | Confirmation | Correction | Reference |
|--|---|--|--|--|
| Absolute Encoder Position Deviation Error (The position that was saved in the host controller when the power was turned OFF is different from the position when the power was next turned ON.) | A failure occurred in the SERVOPACK. | – | Turn OFF the power supply to the servo system. Replace the SERVO-PACK. | – |
| | Host Controller Multiturn Data or Absolute Encoder Position Data Reading Error | Check the error detection section of the host controller. | Correct the error detection section of the host controller. | – |
| | | Check to see if the host controller is executing data parity checks. | Perform parity checks for the multiturn data or absolute encoder position data. | – |
| | | Check for noise interference in the cable between the SERVO-PACK and the host controller. | Implement countermeasures against noise and then perform parity checks again for the multiturn data or absolute encoder position data. | – |
| Overtravel Occurred | The P-OT/N-OT (Forward Drive Prohibit or Reverse Drive Prohibit) signal was input. | Check the external power supply (+24 V) voltage for the input signals. | Correct the external power supply (+24 V) voltage for the input signals. | – |
| | | Check the operating condition of the overtravel limit switches. | Make sure that the overtravel limit switches operate correctly. | – |
| | | Check the wiring of the overtravel limit switches. | Correct the wiring of the overtravel limit switches. | * |
| | | Check the settings of the overtravel input signal allocations (Pn50A/Pn50B). | Set the parameters to correct values. | * |
| | The P-OT/N-OT (Forward Drive Prohibit or Reverse Drive Prohibit) signal malfunctioned. | Check for fluctuation in the external power supply (+24 V) voltage for the input signals. | Eliminate fluctuation from the external power supply (+24 V) voltage for the input signals. | – |
| | | Check to see if the operation of the overtravel limit switches is unstable. | Stabilize the operating condition of the overtravel limit switches. | – |
| | | Check the wiring of the overtravel limit switches (e.g., check for cable damage and loose screws). | Correct the wiring of the overtravel limit switches. | – |
| | There is a mistake in the allocation of the P-OT or N-OT (Forward Drive Prohibit or Reverse Drive Prohibit) signal in Pn50A = n.X□□□ or Pn50B = n.□□□X. | Check to see if the P-OT signal is allocated in Pn50A = n.X□□□. | If another signal is allocated in Pn50A = n.X□□□, allocate the P-OT signal instead. | * |
| | | Check to see if the N-OT signal is allocated in Pn50B = n.□□□X. | If another signal is allocated in Pn50B = n.□□□X, allocate the N-OT signal instead. | * |
| | Overtravel Occurred | The selection of the Servomotor stopping method is not correct. | Check the servo OFF stopping method set in Pn001 = n.□□□X or Pn001 = n.□□X□. | Select a Servomotor stopping method other than coasting to a stop. |
| Check the torque control stopping method set in Pn001 = n.□□□X or Pn001 = n.□□X□. | | | Select a Servomotor stopping method other than coasting to a stop. | * |

Continued on next page.

Continued from previous page.

| Problem | Possible Cause | Confirmation | Correction | Reference |
|---|---|---|--|-----------|
| Improper Stop Position for Overtravel (OT) Signal | The limit switch position and dog length are not appropriate. | – | Install the limit switch at the appropriate position. | – |
| | The overtravel limit switch position is too close for the coasting distance. | – | Install the overtravel limit switch at the appropriate position. | – |
| Position Deviation (without Alarm) | Noise interference occurred because of incorrect Encoder Cable specifications. | Turn OFF the power supply to the servo system. Check the Encoder Cable to see if it satisfies specifications. Use a shielded twisted-pair wire cable or a screened twisted-pair cable with conductors of at least 0.12 mm ² . | Use cables that satisfy the specifications. | – |
| | Noise interference occurred because the Encoder Cable is too long. | Turn OFF the power supply to the servo system. Check the length of the Encoder Cable. | <ul style="list-style-type: none"> Rotary Servomotors: The Encoder Cable length must be 50 m max. Linear Servomotors: Make sure that the Serial Converter Unit cable is no longer than 20 m and that the Linear Encoder Cable and the Sensor Cable are no longer than 15 m each. | – |
| | Noise interference occurred because the Encoder Cable is damaged. | Turn OFF the power supply to the servo system. Check the Encoder Cable to see if it is pinched or the sheath is damaged. | Replace the Encoder Cable and correct the cable installation environment. | – |
| | The Encoder Cable was subjected to excessive noise interference. | Turn OFF the power supply to the servo system. Check to see if the Encoder Cable is bundled with a high-current line or installed near a high-current line. | Correct the cable layout so that no surge is applied by high-current lines. | – |
| | There is variation in the FG potential because of the influence of machines on the Servomotor side, such as a welder. | Turn OFF the power supply to the servo system. Check to see if the machines are correctly grounded. | Properly ground the machines to separate them from the FG of the encoder. | – |
| | There is a SERVOPACK pulse counting error due to noise. | Turn OFF the power supply to the servo system. Check to see if there is noise interference on the I/O signal line from the encoder or Serial Converter Unit. | Implement countermeasures against noise for the encoder wiring or Serial Converter Unit wiring. | – |

Continued on next page.

4.1 SERVOPACKs with Analog Voltage/Pulse Train References

4.1.7 Troubleshooting Based on the Operation and Conditions of the Servomotor

Continued from previous page.

| Problem | Possible Cause | Confirmation | Correction | Reference |
|------------------------------------|---|---|---|-----------|
| Position Deviation (without Alarm) | The encoder was subjected to excessive vibration or shock. | Turn OFF the power supply to the servo system. Check to see if vibration from the machine occurred. Check the Servomotor installation (mounting surface precision, securing state, and alignment). Check the linear encoder installation (mounting surface precision and securing method). | Reduce machine vibration. Improve the mounting state of the Servomotor or linear encoder. | - |
| | The coupling between the machine and Servomotor is not suitable. | Turn OFF the power supply to the servo system. Check to see if position offset occurs at the coupling between machine and Servomotor. | Correctly secure the coupling between the machine and Servomotor. | - |
| | Noise interference occurred because of incorrect I/O signal cable specifications. | Turn OFF the power supply to the servo system. Check the I/O signal cables to see if they satisfy specifications. Use a shielded twisted-pair wire cable or a screened twisted-pair cable with conductors of at least 0.12 mm ² . | Use cables that satisfy the specifications. | - |
| | If reference pulse input multiplication switching is being used, noise may be causing the I/O signals used for this function (/PSEL and /PSELA) to be falsely detected. | Turn OFF the power supply to the servo system. Check the I/O signal cables to see if they satisfy specifications. Use a shielded twisted-pair wire cable or a screened twisted-pair cable with conductors of at least 0.12 mm ² . | Use cables that satisfy the specifications. | - |
| | Noise interference occurred because an I/O signal cable is too long. | Turn OFF the power supply to the servo system. Check the lengths of the I/O signal cables. | The I/O signal cables must be no longer than 3 m. | - |
| | An encoder fault occurred. (The pulse count does not change.) | - | Turn OFF the power supply to the servo system. Replace the Servomotor or linear encoder. | - |
| | A failure occurred in the SERVOPACK. | - | Turn OFF the power supply to the servo system. Replace the SERVOPACK. | - |

Continued on next page.

Continued from previous page.

| Problem | Possible Cause | Confirmation | Correction | Reference |
|-----------------------|---|--|---|-----------|
| Servomotor Overheated | The surrounding air temperature is too high. | Measure the surrounding air temperature around the Servomotor. | Reduce the surrounding air temperature to 40°C or less. | - |
| | The surface of the Servomotor is dirty. | Turn OFF the power supply to the servo system. Visually check the surface for dirt. | Clean dirt, dust, and oil from the surface. | - |
| | There is an overload on the Servomotor. | Check the load status with a monitor. | If the Servomotor is overloaded, reduce the load or replace the Servo Drive with a SERVOPACK and Servomotor with larger capacities. | - |
| | Polarity detection was not performed correctly. | Check to see if electrical angle 2 (electrical angle from polarity origin) at any position is between $\pm 10^\circ$. | Correct the settings for the polarity detection-related parameters. | - |

* Refer to the following manual for details.

 Σ -7-Series Σ -7S SERVOPACK with Analog Voltage/Pulse Train References Product Manual
(Manual No.: SIEP S800001 26)

4.2 SERVOPACKs with MECHATROLINK-III Communications References

4.2.1 Alarm Displays

If an error occurs in the SERVOPACK, an alarm number will be displayed on the panel display. However, if no alarm number appears on the panel display, this indicates a SERVOPACK system error. Replace the SERVOPACK.

If there is an alarm, the display will change in the following order.

Example: Alarm A.E60

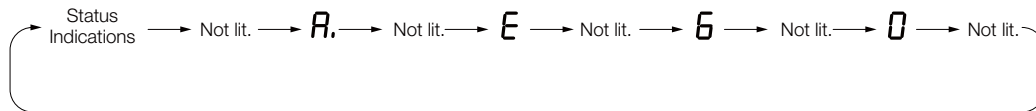

4.2.2 List of Alarms

The list of alarms gives the alarm name, alarm meaning, alarm stopping method, and alarm reset possibility in order of the alarm numbers.

Servomotor Stopping Method for Alarms

Refer to the following manual for information on the stopping method for alarms.

📖 Σ -7-Series Σ -7S SERVOPACK with MECHATROLINK-III Communications References Product Manual (Manual No.: SIEP S800001 28)

Alarm Reset Possibility

Yes: You can use an alarm reset to clear the alarm. However, this assumes that the cause of the alarm has been removed.

No: You cannot clear the alarm.

List of Alarms

| Alarm Number | Alarm Name | Alarm Meaning | Servo-motor Stopping Method | Alarm Reset Possible? |
|--------------|-----------------------------|--|-----------------------------|-----------------------|
| A.020 | Parameter Checksum Error | There is an error in the parameter data in the SERVOPACK. | Gr.1 | No |
| A.021 | Parameter Format Error | There is an error in the parameter data format in the SERVOPACK. | Gr.1 | No |
| A.022 | System Checksum Error | There is an error in the parameter data in the SERVOPACK. | Gr.1 | No |
| A.024 | System Alarm | An internal program error occurred in the SERVOPACK. | Gr.1 | No |
| A.025 | System Alarm | An internal program error occurred in the SERVOPACK. | Gr.1 | No |
| A.030 | Main Circuit Detector Error | There is an error in the detection data for the main circuit. | Gr.1 | Yes |
| A.040 | Parameter Setting Error | A parameter setting is outside of the setting range. | Gr.1 | No |

Continued on next page.

Continued from previous page.

| Alarm Number | Alarm Name | Alarm Meaning | Servo-motor Stopping Method | Alarm Reset Possible? |
|--------------|---|---|-----------------------------|-----------------------|
| A.041 | Encoder Output Pulse Setting Error | The setting of Pn212 (Number of Encoder Output Pulses) or Pn281 (Encoder Output Resolution) is outside of the setting range or does not satisfy the setting conditions. | Gr.1 | No |
| A.042 | Parameter Combination Error | The combination of some parameters exceeds the setting range. | Gr.1 | No |
| A.044 | Semi-Closed/Fully-Closed Loop Control Parameter Setting Error | The settings of the Option Module and Pn002 = n.X□□□ (External Encoder Usage) do not match. | Gr.1 | No |
| A.04A | Parameter Setting Error 2 | There is an error in the bank members or bank data settings. | Gr.1 | No |
| A.050 | Combination Error | The capacities of the SERVOPACK and Servomotor do not match. | Gr.1 | Yes |
| A.051 | Unsupported Device Alarm | An unsupported device was connected. | Gr.1 | No |
| A.070 | Motor Type Change Detected | The connected motor is a different type of motor from the previously connected motor. | Gr.1 | No |
| A.080 | Linear Encoder Pitch Setting Error | The setting of Pn282 (Linear Encoder Scale Pitch) has not been changed from the default setting. | Gr.1 | No |
| A.0b0 | Invalid Servo ON Command Alarm | The SV_ON (Servo ON) command was sent from the host controller after a utility function that turns ON the Servomotor was executed. | Gr.1 | Yes |
| A.100 | Overcurrent Detected | An overcurrent flowed through the power transistor or the heat sink overheated. | Gr.1 | No |
| A.101 | Motor Overcurrent Detected | The current to the motor exceeded the allowable current. | Gr.1 | No |
| A.300 | Regeneration Error | There is an error related to regeneration. | Gr.1 | Yes |
| A.320 | Regenerative Overload | A regenerative overload occurred. | Gr.2 | Yes |
| A.330 | Main Circuit Power Supply Wiring Error | <ul style="list-style-type: none"> The AC power supply input setting or DC power supply input setting is not correct. The power supply wiring is not correct. | Gr.1 | Yes |
| A.400 | Overvoltage | The main circuit DC voltage is too high. | Gr.1 | Yes |
| A.410 | Undervoltage | The main circuit DC voltage is too low. | Gr.2 | Yes |
| A.510 | Overspeed | The motor exceeded the maximum speed. | Gr.1 | Yes |
| A.511 | Encoder Output Pulse Overspeed | <ul style="list-style-type: none"> Rotary Servomotor: The pulse output speed for the setting of Pn212 (Number of Encoder Output Pulses) was exceeded. Linear Servomotor: The motor speed upper limit for the setting of Pn281 (Encoder Output Resolution) was exceeded. | Gr.1 | Yes |
| A.520 | Vibration Alarm | Abnormal oscillation was detected in the motor speed. | Gr.1 | Yes |
| A.521 | Autotuning Alarm | Vibration was detected during autotuning for the tuning-less function. | Gr.1 | Yes |
| A.550 | Maximum Speed Setting Error | The setting of Pn385 (Maximum Motor Speed) is greater than the maximum motor speed. | Gr.1 | Yes |
| A.710 | Instantaneous Overload | The Servomotor was operating for several seconds to several tens of seconds under a torque that largely exceeded the rating. | Gr.2 | Yes |
| A.720 | Continuous Overload | The Servomotor was operating continuously under a torque that exceeded the rating. | Gr.1 | Yes |
| A.730 | Dynamic Brake Overload | When the dynamic brake was applied, the rotational or linear kinetic energy exceeded the capacity of the dynamic brake resistor. | Gr.1 | Yes |
| A.731 | | | | |

Continued on next page.

Continued from previous page.

| Alarm Number | Alarm Name | Alarm Meaning | Servo-motor Stopping Method | Alarm Reset Possible? |
|--------------|--|---|-----------------------------|-----------------------|
| A.740 | Inrush Current Limiting Resistor Overload | The main circuit power supply was frequently turned ON and OFF. | Gr.1 | Yes |
| A.7A1 | Internal Temperature Error 1 (Control Board Temperature Error) | The surrounding temperature of the control PCB is abnormal. | Gr.2 | Yes |
| A.7A2 | Internal Temperature Error 2 (Power Board Temperature Error) | The surrounding temperature of the power PCB is abnormal. | Gr.2 | Yes |
| A.7A3 | Internal Temperature Sensor Error | An error occurred in the temperature sensor circuit. | Gr.2 | No |
| A.7Ab | SERVOPACK Built-in Fan Stopped | The fan inside the SERVOPACK stopped. | Gr.1 | Yes |
| A.810 | Encoder Backup Alarm | The power supplies to the encoder all failed and the position data was lost. | Gr.1 | No |
| A.820 | Encoder Checksum Alarm | There is an error in the checksum results for encoder memory. | Gr.1 | No |
| A.830 | Encoder Battery Alarm | The battery voltage was lower than the specified level after the control power supply was turned ON. | Gr.1 | Yes |
| A.840 | Encoder Data Alarm | There is an internal data error in the encoder. | Gr.1 | No |
| A.850 | Encoder Overspeed | The encoder was operating at high speed when the power was turned ON. | Gr.1 | No |
| A.860 | Encoder Overheated | The internal temperature of encoder is too high. | Gr.1 | No |
| A.861 | Motor Overheated | The internal temperature of motor is too high. | Gr.1 | No |
| A.862 | Overheat Alarm | The input voltage (temperature) for the overheat protection input (TH) signal exceeded the setting of Pn61B (Overheat Alarm Level). | Gr.1 | Yes |
| A.890 | Encoder Scale Error | A failure occurred in the linear encoder. | Gr.1 | No |
| A.891 | Encoder Module Error | An error occurred in the linear encoder. | Gr.1 | No |
| A.8A0 | External Encoder Error | An error occurred in the external encoder. | Gr.1 | Yes |
| A.8A1 | External Encoder Module Error | An error occurred in the Serial Converter Unit. | Gr.1 | Yes |
| A.8A2 | External Incremental Encoder Sensor Error | An error occurred in the external encoder. | Gr.1 | Yes |
| A.8A3 | External Absolute Encoder Position Error | An error occurred in the position data of the external encoder. | Gr.1 | Yes |
| A.8A5 | External Encoder Overspeed | An overspeed error occurred in the external encoder. | Gr.1 | Yes |
| A.8A6 | External Encoder Overheated | An overheating error occurred in the external encoder. | Gr.1 | Yes |
| A.b33 | Current Detection Error 3 | An error occurred in the current detection circuit. | Gr.1 | No |
| A.b6A | MECHATROLINK Communications ASIC Error 1 | ASIC error 1 occurred in MECHATROLINK communications. | Gr.1 | No |
| A.b6b | MECHATROLINK Communications ASIC Error 2 | ASIC error 2 occurred in MECHATROLINK communications. | Gr.2 | No |
| A.bF0 | System Alarm 0 | Internal program error 0 occurred in the SERVOPACK. | Gr.1 | No |
| A.bF1 | System Alarm 1 | Internal program error 1 occurred in the SERVOPACK. | Gr.1 | No |
| A.bF2 | System Alarm 2 | Internal program error 2 occurred in the SERVOPACK. | Gr.1 | No |

Continued on next page.

Continued from previous page.

| Alarm Number | Alarm Name | Alarm Meaning | Servo-motor Stopping Method | Alarm Reset Possible? |
|--------------|---|---|-----------------------------|-----------------------|
| A.bF3 | System Alarm 3 | Internal program error 3 occurred in the SERVOPACK. | Gr.1 | No |
| A.bF4 | System Alarm 4 | Internal program error 4 occurred in the SERVOPACK. | Gr.1 | No |
| A.bF5 | System Alarm 5 | Internal program error 5 occurred in the SERVOPACK. | Gr.1 | No |
| A.bF6 | System Alarm 6 | Internal program error 6 occurred in the SERVOPACK. | Gr.1 | No |
| A.bF7 | System Alarm 7 | Internal program error 7 occurred in the SERVOPACK. | Gr.1 | No |
| A.bF8 | System Alarm 8 | Internal program error 8 occurred in the SERVOPACK. | Gr.1 | No |
| A.C10 | Servomotor Out of Control | The Servomotor ran out of control. | Gr.1 | Yes |
| A.C20 | Phase Detection Error | The detection of the phase is not correct. | Gr.1 | No |
| A.C21 | Polarity Sensor Error | An error occurred in the polarity sensor. | Gr.1 | No |
| A.C22 | Phase Information Disagreement | The phase information does not match. | Gr.1 | No |
| A.C50 | Polarity Detection Failure | The polarity detection failed. | Gr.1 | No |
| A.C51 | Overtravel Detected during Polarity Detection | The overtravel signal was detected during polarity detection. | Gr.1 | Yes |
| A.C52 | Polarity Detection Not Completed | The servo was turned ON before the polarity was detected. | Gr.1 | Yes |
| A.C53 | Out of Range of Motion for Polarity Detection | The travel distance exceeded the setting of Pn48E (Polarity Detection Range). | Gr.1 | No |
| A.C54 | Polarity Detection Failure 2 | The polarity detection failed. | Gr.1 | No |
| A.C80 | Encoder Clear Error or Multiturn Limit Setting Error | The multiturn data for the absolute encoder was not correctly cleared or set. | Gr.1 | No |
| A.C90 | Encoder Communications Error | Communications between the encoder and SERVOPACK is not possible. | Gr.1 | No |
| A.C91 | Encoder Communications Position Data Acceleration Rate Error | An error occurred in calculating the position data of the encoder. | Gr.1 | No |
| A.C92 | Encoder Communications Timer Error | An error occurred in the communications timer between the encoder and SERVOPACK. | Gr.1 | No |
| A.CA0 | Encoder Parameter Error | The parameters in the encoder are corrupted. | Gr.1 | No |
| A.Cb0 | Encoder Echoback Error | The contents of communications with the encoder are incorrect. | Gr.1 | No |
| A.CC0 | Multiturn Limit Disagreement | Different multiturn limits have been set in the encoder and the SERVOPACK. | Gr.1 | No |
| A.CF1 | Reception Failed Error in Feedback Option Module Communications | Receiving data from the Feedback Option Module failed. | Gr.1 | No |
| A.CF2 | Timer Stopped Error in Feedback Option Module Communications | An error occurred in the timer for communications with the Feedback Option Module. | Gr.1 | No |
| A.d00 | Position Deviation Overflow | The setting of Pn520 (Position Deviation Overflow Alarm Level) was exceeded by the position deviation while the servo was ON. | Gr.1 | Yes |

Continued on next page.

4.2 SERVOPACKs with MECHATROLINK-III Communications References

4.2.2 List of Alarms

Continued from previous page.

| Alarm Number | Alarm Name | Alarm Meaning | Servo-motor Stopping Method | Alarm Reset Possible? |
|--------------|---|--|-----------------------------|-----------------------|
| A.d01 | Position Deviation Overflow Alarm at Servo ON | The servo was turned ON after the position deviation exceeded the setting of Pn526 (Position Deviation Overflow Alarm Level at Servo ON) while the servo was OFF. | Gr. 1 | Yes |
| A.d02 | Position Deviation Overflow Alarm for Speed Limit at Servo ON | If position deviation remains in the deviation counter, the setting of Pn529 or Pn584 (Speed Limit Level at Servo ON) limits the speed when the servo is turned ON. This alarm occurs if a position reference is input and the setting of Pn520 (Position Deviation Overflow Alarm Level) is exceeded before the limit is cleared. | Gr.2 | Yes |
| A.d10 | Motor-Load Position Deviation Overflow | There was too much position deviation between the motor and load during fully-closed loop control. | Gr.2 | Yes |
| A.d30 | Position Data Overflow | The position feedback data exceeded $\pm 1,879,048,192$. | Gr. 1 | No |
| A.E02 | MECHATROLINK Internal Synchronization Error 1 | A synchronization error occurred during MECHATROLINK communications with the SERVOPACK. | Gr. 1 | Yes |
| A.E40 | MECHATROLINK Transmission Cycle Setting Error | The setting of the MECHATROLINK communications transmission cycle is not correct. | Gr.2 | Yes |
| A.E41 | MECHATROLINK Communications Data Size Setting Error | The setting of the MECHATROLINK communications data size is not correct. | Gr.2 | Yes |
| A.E42 | MECHATROLINK Station Address Setting Error | The setting of the MECHATROLINK station address is not correct. | Gr.2 | No |
| A.E50* | MECHATROLINK Synchronization Error | A synchronization error occurred during MECHATROLINK communications. | Gr.2 | Yes |
| A.E51 | MECHATROLINK Synchronization Failed | Synchronization failed during MECHATROLINK communications. | Gr.2 | Yes |
| A.E60* | Reception Error in MECHATROLINK Communications | Communications errors occurred continuously during MECHATROLINK communications. | Gr.2 | Yes |
| A.E61 | Synchronization Interval Error in MECHATROLINK Transmission Cycle | An error occurred in the transmission cycle during MECHATROLINK communications. | Gr.2 | Yes |
| A.E63 | MECHATROLINK Synchronization Frame Not Received | Synchronization frames were continuously not received during MECHATROLINK communications. | Gr.2 | Yes |
| A.E71 | Safety Option Module Detection Failure | Detection of the Safety Option Module failed. | Gr. 1 | No |
| A.E72 | Feedback Option Module Detection Failure | Detection of the Feedback Option Module failed. | Gr. 1 | No |
| A.E74 | Unsupported Safety Option Module | An unsupported Safety Option Module was connected. | Gr. 1 | No |
| A.Eb1 | Safety Function Signal Input Timing Error | An error occurred in the input timing of the safety function signal. | Gr. 1 | No |
| A.EC8 | Gate Drive Error 1 | An error occurred in the gate drive circuit. | Gr. 1 | No |
| A.EC9 | Gate Drive Error 2 | An error occurred in the gate drive circuit. | Gr. 1 | No |
| A.Ed1 | Command Execution Timeout | A timeout error occurred for a MECHATROLINK command. | Gr.2 | Yes |

Continued on next page.

Continued from previous page.

| Alarm Number | Alarm Name | Alarm Meaning | Servo-motor Stopping Method | Alarm Reset Possible? |
|--------------|---|---|-----------------------------|-----------------------|
| A.F10 | Power Supply Line Open Phase | The voltage was low for more than one second for phase R, S, or T when the main power supply was ON. | Gr.2 | Yes |
| FL-1* | System Alarm | An internal program error occurred in the SERVOPACK. | - | No |
| FL-2* | | | | |
| FL-3* | | | | |
| FL-4* | | | | |
| FL-5* | | | | |
| FL-6* | | | | |
| CPF00 | Digital Operator Communications Error 1 | Communications were not possible between the Digital Operator (model: JUSP-OP05A-1-E) and the SERVOPACK (e.g., a CPU error occurred). | - | No |
| CPF01 | Digital Operator Communications Error 2 | | | |

* These alarms are not stored in the alarm history. They are only displayed on the panel display.

Note: The A.Eb0, A.Eb2 to A.Eb9, and A.EC0 to A.EC2 alarms can occur when a Safety Module is connected.

Refer to the following manual for details.

 AC Servo Drive Σ -V-Series/ Σ -V-Series for Large-Capacity Models/ Σ -7-Series User's Manual Safety Module (Manual No.: SIEP C720829 06)

4.2.3 Troubleshooting Alarms

The causes of and corrections for the alarms are given in the following table. Contact your Yaskawa representative if you cannot solve a problem with the correction given in the table.

| Alarm Number: Alarm Name | Possible Cause | Confirmation | Correction | Reference |
|---|--|---|--|-----------|
| A.020: Parameter Checksum Error (There is an error in the parameter data in the SER- VOPACK.) | The power supply voltage suddenly dropped. | Measure the power supply voltage. | Set the power supply voltage within the specified range, and initialize the parameter settings. | *1 |
| | The power supply was shut OFF while writing parameter settings. | Check the timing of shutting OFF the power supply. | Initialize the parameter settings and then set the parameters again. | *1 |
| | The number of times that parameters were written exceeded the limit. | Check to see if the parameters were frequently changed from the host controller. | The SERVOPACK may be faulty. Replace the SERVOPACK. Reconsider the method for writing the parameters. | — |
| | A malfunction was caused by noise from the AC power supply, ground, static electricity, or other source. | Turn the power supply to the SERVOPACK OFF and ON again. If the alarm still occurs, noise may be the cause. | Implement countermeasures against noise. | *1 |
| | Gas, water drops, or cutting oil entered the SERVOPACK and caused failure of the internal components. | Check the installation conditions. | The SERVOPACK may be faulty. Replace the SERVOPACK. | — |
| | A failure occurred in the SERVOPACK. | Turn the power supply to the SERVOPACK OFF and ON again. If the alarm still occurs, the SERVOPACK may have failed. | The SERVOPACK may be faulty. Replace the SERVOPACK. | — |
| A.021: Parameter Format Error (There is an error in the parameter data format in the SERVOPACK.) | The software version of the SERVOPACK that caused the alarm is older than the software version of the parameters specified to write. | Read the product information to see if the software versions are the same. If they are different, it could be the cause of the alarm. | Write the parameters from another SERVOPACK with the same model and the same software version, and then turn the power OFF and ON again. | *1 |
| | A failure occurred in the SERVOPACK. | — | The SERVOPACK may be faulty. Replace the SERVOPACK. | — |
| A.022: System Checksum Error (There is an error in the parameter data in the SERVOPACK.) | The power supply voltage suddenly dropped. | Measure the power supply voltage. | The SERVOPACK may be faulty. Replace the SERVOPACK. | — |
| | The power supply was shut OFF while setting a utility function. | Check the timing of shutting OFF the power supply. | The SERVOPACK may be faulty. Replace the SERVOPACK. | — |
| | A failure occurred in the SERVOPACK. | Turn the power supply to the SERVOPACK OFF and ON again. If the alarm still occurs, the SERVOPACK may have failed. | The SERVOPACK may be faulty. Replace the SERVOPACK. | — |

Continued on next page.

Continued from previous page.

| Alarm Number: Alarm Name | Possible Cause | Confirmation | Correction | Reference |
|--|---|---|--|-----------|
| A.024: System Alarm (An internal program error occurred in the SERVOPACK.) | A failure occurred in the SERVOPACK. | – | The SERVOPACK may be faulty. Replace the SERVOPACK. | – |
| A.025: System Alarm (An internal program error occurred in the SERVOPACK.) | A failure occurred in the SERVOPACK. | – | The SERVOPACK may be faulty. Replace the SERVOPACK. | – |
| A.030: Main Circuit Detector Error | A failure occurred in the SERVOPACK. | – | The SERVOPACK may be faulty. Replace the SERVOPACK. | – |
| A.040: Parameter Setting Error (A parameter setting is outside of the setting range.) | The SERVOPACK and Servomotor capacities do not match each other. | Check the combination of the SERVOPACK and Servomotor capacities. | Select a proper combination of SERVOPACK and Servomotor capacities. | *1 |
| | The motor parameter file was not written to the linear encoder. (This applies only when not using a Serial Converter Unit.) | Check to see if the motor parameter file was written to the linear encoder. | Write the motor parameter file to the linear encoder. | *1 |
| | A failure occurred in the SERVOPACK. | – | The SERVOPACK may be faulty. Replace the SERVOPACK. | – |
| | A parameter setting is outside of the setting range. | Check the setting ranges of the parameters that have been changed. | Set the parameters to values within the setting ranges. | – |
| | The electronic gear ratio is outside of the setting range. | Check the electronic gear ratio. The ratio must be within the following range: $0.001 < (\text{Pn20E}/\text{Pn210}) < 64,000$. | Set the electronic gear ratio in the following range: $0.001 < (\text{Pn20E}/\text{Pn210}) < 64,000$. | *1 |
| A.041: Encoder Output Pulse Setting Error | The setting of Pn212 (Number of Encoder Output Pulses) or Pn281 (Encoder Output Resolution) is outside of the setting range or does not satisfy the setting conditions. | Check the setting of Pn212 or Pn281. | Set Pn212 or Pn281 to an appropriate value. | *1 |

Continued on next page.

Continued from previous page.

| Alarm Number: Alarm Name | Possible Cause | Confirmation | Correction | Reference |
|---|---|---|--|-----------|
| A.042: Parameter Combination Error | The speed of program jogging went below the setting range when the electronic gear ratio (Pn20E/ Pn210) or the Servomotor was changed. | Check to see if the detection conditions*2 are satisfied. | Decrease the setting of the electronic gear ratio (Pn20E/Pn210). | *1 |
| | The speed of program jogging went below the setting range when Pn533 or Pn585 (Program Jogging Movement Speed) was changed. | Check to see if the detection conditions*2 are satisfied. | Increase the setting of Pn533 or Pn585. | *1 |
| | The movement speed of advanced autotuning went below the setting range when the electronic gear ratio (Pn20E/ Pn210) or the Servomotor was changed. | Check to see if the detection conditions*3 are satisfied. | Decrease the setting of the electronic gear ratio (Pn20E/Pn210). | *1 |
| A.044: Semi-Closed/ Fully-Closed Loop Control Parameter Setting Error | The setting of the Fully-closed Module does not match the setting of Pn002 = n.X□□□ (External Encoder Usage). | Check the setting of Pn002 = n.X□□□. | Make sure that the setting of the Fully-closed Module agrees with the setting of Pn002 = n.X□□□. | *1 |
| A.04A: Parameter Setting Error 2 | For 4-byte parameter bank members, there are two consecutive members with nothing registered. | – | Change the number of bytes for bank members to an appropriate value. | – |
| | The total amount of bank data exceeds 64 (Pn900 × Pn901 > 64). | – | Reduce the total amount of bank data to 64 or less. | – |
| A.050: Combination Error (The capacities of the SERVOPACK and Servomotor do not match.) | The SERVOPACK and Servomotor capacities do not match each other. | Confirm that the following condition is met: $1/4 \leq (\text{Servomotor capacity}/\text{SERVOPACK capacity}) \leq 4$ | Select a proper combination of the SERVOPACK and Servomotor capacities. | *1 |
| | A failure occurred in the encoder. | Replace the encoder and check to see if the alarm still occurs. | Replace the Servomotor or encoder. | – |
| | A failure occurred in the SERVOPACK. | – | The SERVOPACK may be faulty. Replace the SERVOPACK. | – |
| A.051: Unsupported Device Alarm | The motor parameter file was not written to the linear encoder. (This applies only when not using a Serial Converter Unit.) | Check to see if the motor parameter file was written to the linear encoder. | Write the motor parameter file to the linear encoder. | *1 |
| | An unsupported Serial Converter Unit or encoder (e.g., an external encoder) is connected to the SERVOPACK. | Check the product combination specifications. | Change to a correct combination of models. | – |

Continued on next page.

Continued from previous page.

| Alarm Number: Alarm Name | Possible Cause | Confirmation | Correction | Reference |
|---|--|--------------------------------|---|-----------|
| A.070: Motor Type Change Detected (The connected motor is a differ- ent type of motor from the previ- ously connected motor.) | A Rotary Servomotor was removed and a Linear Servomotor was connected. | – | Set the parameters for a Linear Servomotor and reset the motor type alarm. Then, turn the power supply to the SER- VOPACK OFF and ON again. | *1 |
| | A Linear Servomotor was removed and a Rotary Servomotor was connected. | – | Set the parameters for a Rotary Servomotor and reset the motor type alarm. Then, turn the power supply to the SER- VOPACK OFF and ON again. | *1 |
| A.080: Linear Encoder Pitch Setting Error | The setting of Pn282 (Linear Encoder Scale Pitch) has not been changed from the default setting. | Check the setting of Pn282. | Correct the setting of Pn282. | *1 |
| A.0b0: Invalid Servo ON Command Alarm | The SV_ON (Servo ON) command was sent from the host controller after a util- ity function that turns ON the Servomotor was executed. | – | Turn the power supply to the SERVOPACK OFF and ON again. Or, execute a software reset. | *1 |

Continued on next page.

Continued from previous page.

| Alarm Number: Alarm Name | Possible Cause | Confirmation | Correction | Reference |
|--|---|--|--|-----------|
| A.100: Overcurrent Detected (An overcurrent flowed through the power trans- istor or the heat sink overheated.) | The Main Circuit Cable is not wired correctly or there is faulty contact. | Check the wiring. | Correct the wiring. | *1 |
| | There is a short-circuit or ground fault in a Main Circuit Cable. | Check for short-circuits across Servomotor phases U, V, and W, or between the ground and Servomotor phases U, V, and W. | The cable may be short-circuited. Replace the cable. | *1 |
| | There is a short-circuit or ground fault inside the Servomotor. | Check for short-circuits across Servomotor phases U, V, and W, or between the ground and Servomotor phases U, V, or W. | The Servomotor may be faulty. Replace the Servomotor. | *1 |
| | There is a short-circuit or ground fault inside the SERVOPACK. | Check for short-circuits across the Servomotor connection terminals U, V, and W on the SERVOPACK, or between the ground and terminals U, V, or W. | The SERVOPACK may be faulty. Replace the SERVOPACK. | *1 |
| | The regenerative resistor is not wired correctly or there is faulty contact. | Check the wiring. | Correct the wiring. | *1 |
| | The dynamic brake (DB, emergency stop executed from the SERVOPACK) was frequently activated, or a DB overload alarm occurred. | Check the power consumed by the DB resistor to see how frequently the DB is being used. Or, check the alarm display to see if a DB overload alarm (A.730 or A.731) has occurred. | Change the SERVOPACK model, operating methods, or the mechanisms so that the dynamic brake does not need to be used so frequently. | — |
| | The regenerative processing capacity was exceeded. | Check the regenerative load ratio in the SigmaWin+ Motion Monitor Tab Page to see how frequently the regenerative resistor is being used. | Recheck the operating conditions and load. | *4 |
| | The SERVOPACK regenerative resistance is too small. | Check the regenerative load ratio in the SigmaWin+ Motion Monitor Tab Page to see how frequently the regenerative resistor is being used. | Change the regenerative resistance to a value larger than the SERVOPACK minimum allowable resistance. | *4 |

Continued on next page.

Continued from previous page.

| Alarm Number: Alarm Name | Possible Cause | Confirmation | Correction | Reference |
|--|--|---|--|-----------|
| A.100: Overcurrent Detected (An overcurrent flowed through the power trans- istor or the heat sink overheated.) | A heavy load was applied while the Servomotor was stopped or running at a low speed. | Check to see if the operating conditions exceed Servo Drive specifications. | Reduce the load applied to the Servomotor. Or, increase the operating speed. | – |
| | A malfunction was caused by noise. | Improve the noise environment, e.g. by improving the wiring or installation conditions, and check to see if the alarm still occurs. | Implement countermeasures against noise, such as correct wiring of the FG. Use an FG wire size equivalent to the SERVOPACK's main circuit wire size. | – |
| | A failure occurred in the SERVOPACK. | – | Turn the power supply to the SERVOPACK OFF and ON again. If an alarm still occurs, the SERVOPACK may be faulty. Replace the SERVOPACK. | – |
| A.101: Motor Overcur- rent Detected (The current to the motor exceeded the allowable cur- rent.) | The Main Circuit Cable is not wired correctly or there is faulty contact. | Check the wiring. | Correct the wiring. | *1 |
| | There is a short-circuit or ground fault in a Main Circuit Cable. | Check for short-circuits across cable phases U, V, and W, or between the ground and cable phases U, V, and W. | The cable may be short-circuited. Replace the cable. | *1 |
| | There is a short-circuit or ground fault inside the Servomotor. | Check for short-circuits across Servomotor phases U, V, and W, or between the ground and Servomotor phases U, V, or W. | The Servomotor may be faulty. Replace the Servomotor. | *1 |
| | There is a short-circuit or ground fault inside the SERVOPACK. | Check for short-circuits across the Servomotor connection terminals U, V, and W on the SERVOPACK, or between the ground and terminals U, V, or W. | The SERVOPACK may be faulty. Replace the SERVOPACK. | *1 |
| | A heavy load was applied while the Servomotor was stopped or running at a low speed. | Check to see if the operating conditions exceed Servo Drive specifications. | Reduce the load applied to the Servomotor. Or, increase the operating speed. | – |
| | A malfunction was caused by noise. | Improve the noise environment, e.g. by improving the wiring or installation conditions, and check to see if the alarm still occurs. | Implement countermeasures against noise, such as correct wiring of the FG. Use an FG wire size equivalent to the SERVOPACK's main circuit wire size. | – |
| | A failure occurred in the SERVOPACK. | – | Turn the power supply to the SERVOPACK OFF and ON again. If an alarm still occurs, the SERVOPACK may be faulty. Replace the SERVOPACK. | – |

Continued on next page.

Continued from previous page.

| Alarm Number: Alarm Name | Possible Cause | Confirmation | Correction | Reference |
|---------------------------------|--|--|---|-----------|
| A.300: Regeneration Error | When using the built-in regenerative resistor, the jumper between the regenerative resistor terminals (B2 and B3) was removed from one of the following SERVOPACKs: SGD7S-3R8A, -5R5A, -7R6A, -120A, -180A, -200A, or -330A. | Check to see if the jumper is connected between power supply terminals B2 and B3.*5 | Correctly connect a jumper. | *1 |
| | The External Regenerative Resistor or Regenerative Resistor Unit is not wired correctly, or was removed or disconnected. | Check the wiring of the External Regenerative Resistor or Regenerative Resistor Unit.*5 | Correct the wiring of the External Regenerative Resistor or Regenerative Resistor Unit. | *1 |
| | Pn600 (Regenerative Resistor Capacity) is not set to 0 and an External Regenerative Resistor is not connected to one of the following SERVOPACKs: SGD7S-R70A, -R90A, -1R6A, -2R8A, -R70F, -R90F, -2R1F, or -2R8F. | Check to see if an External Regenerative Resistor is connected and check the setting of Pn600. | Connect an External Regenerative Resistor, or set Pn600 (Regenerative Resistor Capacity) to 0 (setting unit: x10 W) if no Regenerative Resistor is required. | *1 |
| | An External Regenerative Resistor is not connected to one of the following SERVOPACKs: SGD7S-470A, -550A, -590A, or -780A. | Check to see if an External Regenerative Resistor or a Regenerative Resistor Unit is connected and check the setting of Pn600. | Connect an External Regenerative Resistor and set Pn600 to an appropriate value, or connect a Regenerative Resistor Unit and set Pn600 to 0. | *1 |
| | A failure occurred in the SERVOPACK. | - | While the main circuit power supply is OFF, turn the control power supply to the SERVOPACK OFF and ON again. If the alarm still occurs, the SERVOPACK may be faulty. Replace the SERVOPACK. | - |

Continued on next page.

Continued from previous page.

| Alarm Number: Alarm Name | Possible Cause | Confirmation | Correction | Reference |
|------------------------------------|---|--|--|-----------|
| A.320: Regenerative Overload | The power supply voltage exceeded the specified range. | Measure the power supply voltage. | Set the power supply voltage within the specified range. | – |
| | The external regenerative resistance value or regenerative resistor capacity is too small, or there has been a continuous regeneration state. | Check the operating conditions or the capacity using the SigmaJunmaSize+ Capacity Selection Software or other means. | Change the regenerative resistance value or capacity. Reconsider the operating conditions using the SigmaJunmaSize+ Capacity Selection Software or other means. | *4 |
| | There was a continuous regeneration state because a negative load was continuously applied. | Check the load applied to the Servomotor during operation. | Reconsider the system including the servo, machine, and operating conditions. | – |
| | The setting of Pn600 (Regenerative Resistor Capacity) is smaller than the capacity of the External Regenerative Resistor. | Check to see if a Regenerative Resistor is connected and check the setting of Pn600. | Correct the setting of Pn600. | *1 |
| | The setting of Pn603 (Regenerative Resistance) is smaller than the capacity of the External Regenerative Resistor. | Check to see if a Regenerative Resistor is connected and check the setting of Pn603. | Correct the setting of Pn603. | *1 |
| | The external regenerative resistance is too high. | Check the regenerative resistance. | Change the regenerative resistance to a correct value or use an External Regenerative Resistor of an appropriate capacity. | *4 |
| | A failure occurred in the SERVOPACK. | – | The SERVOPACK may be faulty. Replace the SERVOPACK. | – |

Continued on next page.

Continued from previous page.

| Alarm Number: Alarm Name | Possible Cause | Confirmation | Correction | Reference |
|---|---|--|--|-----------|
| A.330: Main Circuit Power Supply Wiring Error (Detected when the main circuit power supply is turned ON.) | The regenerative resistor was disconnected when the SERVOPACK power supply voltage was high. | Measure the resistance of the regenerative resistor using a measuring instrument. | If you are using the regenerative resistor built into the SERVOPACK, replace the SERVOPACK. If you are using an External Regenerative Resistor, replace the External Regenerative Resistor. | – |
| | DC power was supplied when an AC power supply input was specified in the settings. | Check the power supply to see if it is a DC power supply. | Correct the power supply setting to match the actual power supply. | *1 |
| | AC power was supplied when a DC power supply input was specified in the settings. | Check the power supply to see if it is an AC power supply. | Correct the power supply setting to match the actual power supply. | *1 |
| | Pn600 (Regenerative Resistor Capacity) is not set to 0 and an External Regenerative Resistor is not connected to one of the following SERVOPACKs: SGD7S-R70A, -R90A, -1R6A, -2R8A, -R70F, -R90F, -2R1F, or -2R8F. | Check to see if an External Regenerative Resistor is connected and check the setting of Pn600. | Connect an External Regenerative Resistor, or if an External Regenerative Resistor is not required, set Pn600 to 0. | *1 |
| | A failure occurred in the SERVOPACK. | – | The SERVOPACK may be faulty. Replace the SERVOPACK. | – |

Continued on next page.

Continued from previous page.

| Alarm Number: Alarm Name | Possible Cause | Confirmation | Correction | Reference |
|---|---|--|---|-----------|
| A.400: Overvoltage (Detected in the main circuit power supply section of the SERVOPACK.) | The power supply voltage exceeded the specified range. | Measure the power supply voltage. | Set the AC/DC power supply voltage within the specified range. | – |
| | The power supply is not stable or was influenced by a lightning surge. | Measure the power supply voltage. | Improve the power supply conditions, install a surge absorber, and then turn the power supply OFF and ON again. If an alarm still occurs, the SERVOPACK may be faulty. Replace the SERVOPACK. | – |
| | The voltage for AC power supply was too high during acceleration or deceleration. | Check the power supply voltage and the speed and torque during operation. | Set the AC power supply voltage within the specified range. | – |
| | The external regenerative resistance is too high for the operating conditions. | Check the operating conditions and the regenerative resistance. | Select a regenerative resistance value that is appropriate for the operating conditions and load. | *4 |
| | The moment of inertia ratio or mass ratio exceeded the allowable value. | Check to see if the moment of inertia ratio or mass ratio is within the allowable range. | Increase the deceleration time, or reduce the load. | – |
| | A failure occurred in the SERVOPACK. | – | While the main circuit power supply is OFF, turn the control power supply to the SERVOPACK OFF and ON again. If an alarm still occurs, the SERVOPACK may be faulty. Replace the SERVOPACK. | – |
| A.410: Undervoltage (Detected in the main circuit power supply section of the SERVOPACK.) | The power supply voltage went below the specified range. | Measure the power supply voltage. | Set the power supply voltage within the specified range. | – |
| | The power supply voltage dropped during operation. | Measure the power supply voltage. | Increase the power supply capacity. | – |
| | A momentary power interruption occurred. | Measure the power supply voltage. | If you have changed the setting of Pn509 (Momentary Power Interruption Hold Time), decrease the setting. | *1 |
| | The SERVOPACK fuse is blown out. | – | Replace the SERVOPACK and connect a reactor to the DC reactor terminals (⊖1 and ⊖2) on the SERVOPACK. | – |
| | A failure occurred in the SERVOPACK. | – | The SERVOPACK may be faulty. Replace the SERVOPACK. | – |

Continued on next page.

Continued from previous page.

| Alarm Number: Alarm Name | Possible Cause | Confirmation | Correction | Reference |
|--|---|--|---|-----------|
| A.510: Overspeed (The motor exceeded the maximum speed.) | The order of phases U, V, and W in the motor wiring is not correct. | Check the wiring of the Servomotor. | Make sure that the Servomotor is correctly wired. | – |
| | A reference value that exceeded the over-speed detection level was input. | Check the input reference. | Reduce the reference value. Or, adjust the gain. | – |
| | The motor exceeded the maximum speed. | Check the waveform of the motor speed. | Reduce the speed reference input gain and adjust the servo gain. Or, reconsider the operating conditions. | – |
| | A failure occurred in the SERVOPACK. | – | The SERVOPACK may be faulty. Replace the SERVOPACK. | – |
| A.511: Encoder Output Pulse Overspeed | The encoder output pulse frequency exceeded the limit. | Check the encoder output pulse setting. | Decrease the setting of Pn212 (Number of Encoder Output Pulses) or Pn281 (Encoder Output Resolution). | *1 |
| | The encoder output pulse frequency exceeded the limit because the motor speed was too high. | Check the encoder output pulse setting and the motor speed. | Reduce the motor speed. | – |
| A.520: Vibration Alarm | Abnormal oscillation was detected in the motor speed. | Check for abnormal motor noise, and check the speed and torque waveforms during operation. | Reduce the motor speed. Or, reduce the setting of Pn100 (Speed Loop Gain). | *1 |
| | The setting of Pn103 (Moment of Inertia Ratio) is greater than the actual moment of inertia or was greatly changed. | Check the moment of inertia ratio or mass ratio. | Set Pn103 (Moment of Inertia Ratio) to an appropriate value. | *1 |
| | The vibration detection level (Pn312 or Pn384) is not suitable. | Check that the vibration detection level (Pn312 or Pn384) is suitable. | Set a suitable vibration detection level (Pn312 or Pn384). | *1 |
| A.521: Autotuning Alarm (Vibration was detected while executing the custom tuning, Easy FFT, or the tuning-less function.) | The Servomotor vibrated considerably while performing the tuning-less function. | Check the waveform of the motor speed. | Reduce the load so that the moment of inertia ratio is within the allowable value. Or increase the load level or reduce the rigidity level in the tuning-less level settings. | *1 |
| | The Servomotor vibrated considerably while performing custom tuning or Easy FFT. | Check the waveform of the motor speed. | Check the operating procedure of corresponding function and implement corrections. | *1 |
| A.550: Maximum Speed Setting Error | The setting of Pn385 (Maximum Motor Speed) is greater than the maximum speed. | Check the setting of Pn385, and the upper limits of the maximum motor speed setting and the encoder output resolution setting. | Set Pn385 to a value that does not exceed the maximum motor speed. | *1 |

Continued on next page.

Continued from previous page.

| Alarm Number: Alarm Name | Possible Cause | Confirmation | Correction | Reference |
|--|--|---|---|-----------|
| A.710: Instantaneous Overload A.720: Continuous Overload | The wiring is not correct or there is a faulty connection in the motor or encoder wiring. | Check the wiring. | Make sure that the Servomotor and encoder are correctly wired. | *1 |
| | Operation was performed that exceeded the overload protection characteristics. | Check the motor overload characteristics and Run command. | Reconsider the load and operating conditions. Or, increase the motor capacity. | – |
| | An excessive load was applied during operation because the Servomotor was not driven due to mechanical problems. | Check the operation reference and motor speed. | Correct the mechanical problem. | – |
| | There is an error in the setting of Pn282 (Linear Encoder Scale Pitch). | Check the setting of Pn282. | Correct the setting of Pn282. | *1 |
| | There is an error in the setting of Pn080 = n.□□X□ (Motor Phase Sequence Selection). | Check the setting of Pn080 = n.□□X□. | Set Pn080 = n.□□X□ to an appropriate value. | *1 |
| | A failure occurred in the SERVOPACK. | – | The SERVOPACK may be faulty. Replace the SERVOPACK. | – |
| A.730 and A.731: Dynamic Brake Overload (An excessive power consumption by the dynamic brake was detected.) | The Servomotor was rotated by an external force. | Check the operation status. | Implement measures to ensure that the motor will not be rotated by an external force. | – |
| | When the Servomotor was stopped with the dynamic brake, the rotational or linear kinetic energy exceeded the capacity of the dynamic brake resistor. | Check the power consumed by the DB resistor to see how frequently the DB is being used. | Reconsider the following: <ul style="list-style-type: none"> • Reduce the Servomotor command speed. • Decrease the moment of inertia ratio or mass ratio. • Reduce the frequency of stopping with the dynamic brake. | – |
| | A failure occurred in the SERVOPACK. | – | The SERVOPACK may be faulty. Replace the SERVOPACK. | – |
| A.740: Inrush Current Limiting Resistor Overload (The main circuit power supply was frequently turned ON and OFF.) | The allowable frequency of the inrush current limiting resistor was exceeded when the main circuit power supply was turned ON and OFF. | – | Reduce the frequency of turning the main circuit power supply ON and OFF. | – |
| | A failure occurred in the SERVOPACK. | – | The SERVOPACK may be faulty. Replace the SERVOPACK. | – |

Continued on next page.

Continued from previous page.

| Alarm Number: Alarm Name | Possible Cause | Confirmation | Correction | Reference |
|---|--|---|--|-----------|
| A.7A1: Internal Temperature Error 1 (Control Board Temperature Error) | The surrounding temperature is too high. | Check the surrounding temperature using a thermometer. Or, check the operating status with the SERVOPACK installation environment monitor. | Decrease the surrounding temperature by improving the SERVOPACK installation conditions. | *1 |
| | An overload alarm was reset by turning OFF the power supply too many times. | Check the alarm display to see if there is an overload alarm. | Change the method for resetting the alarm. | – |
| | There was an excessive load or operation was performed that exceeded the regenerative processing capacity. | Use the accumulated load ratio to check the load during operation, and use the regenerative load ratio to check the regenerative processing capacity. | Reconsider the load and operating conditions. | – |
| | The SERVOPACK installation orientation is not correct or there is insufficient space around the SERVOPACK. | Check the SERVOPACK installation conditions. | Install the SERVOPACK according to specifications. | *1 |
| | A failure occurred in the SERVOPACK. | – | The SERVOPACK may be faulty. Replace the SERVOPACK. | – |
| A.7A2: Internal Temperature Error 2 (Power Board Temperature Error) | The surrounding temperature is too high. | Check the surrounding temperature using a thermometer. Or, check the operating status with the SERVOPACK installation environment monitor. | Decrease the surrounding temperature by improving the SERVOPACK installation conditions. | *1 |
| | An overload alarm was reset by turning OFF the power supply too many times. | Check the alarm display to see if there is an overload alarm. | Change the method for resetting the alarm. | – |
| | There was an excessive load or operation was performed that exceeded the regenerative processing capacity. | Use the accumulated load ratio to check the load during operation, and use the regenerative load ratio to check the regenerative processing capacity. | Reconsider the load and operating conditions. | – |
| | The SERVOPACK installation orientation is not correct or there is insufficient space around the SERVOPACK. | Check the SERVOPACK installation conditions. | Install the SERVOPACK according to specifications. | *1 |
| | A failure occurred in the SERVOPACK. | – | The SERVOPACK may be faulty. Replace the SERVOPACK. | – |
| A.7A3: Internal Temperature Sensor Error (An error occurred in the temperature sensor circuit.) | A failure occurred in the SERVOPACK. | – | The SERVOPACK may be faulty. Replace the SERVOPACK. | – |

Continued on next page.

Continued from previous page.

| Alarm Number: Alarm Name | Possible Cause | Confirmation | Correction | Reference |
|--|---|--|---|-----------|
| A.7Ab: SERVOPACK Built-in Fan Stopped | The fan inside the SERVOPACK stopped. | Check for foreign matter inside the SERVOPACK. | Remove foreign matter from the SERVOPACK. If an alarm still occurs, the SERVOPACK may be faulty. Replace the SERVOPACK. | – |
| A.810: Encoder Backup Alarm (Detected at the encoder, but only when an absolute encoder is used.) | The power to the absolute encoder was turned ON for the first time. | Check to see if the power supply was turned ON for the first time. | Set up the encoder. | *1 |
| | The Encoder Cable was disconnected and then connected again. | Check to see if the power supply was turned ON for the first time. | Check the encoder connection and set up the encoder. | *1 |
| | Power is not being supplied both from the control power supply (+5 V) from the SERVOPACK and from the battery power supply. | Check the encoder connector battery and the connector status. | Replace the battery or implement similar measures to supply power to the encoder, and set up the encoder. | *1 |
| | A failure occurred in the absolute encoder. | – | If the alarm still occurs after setting up the encoder again, replace the Servomotor. | – |
| A.820: Encoder Checksum Alarm (Detected at the encoder.) | A failure occurred in the encoder. | – | <ul style="list-style-type: none"> ■ When Using an Absolute Encoder Set up the encoder again. If the alarm still occurs, the Servomotor may be faulty. Replace the Servomotor. ■ When Using a Single-turn Absolute Encoder or Incremental Encoder <ul style="list-style-type: none"> • The Servomotor may be faulty. Replace the Servomotor. • The linear encoder may be faulty. Replace the linear encoder. | *1 |
| | A failure occurred in the SERVOPACK. | – | The SERVOPACK may be faulty. Replace the SERVOPACK. | – |
| A.830: Encoder Battery Alarm (The absolute encoder battery voltage was lower than the specified level.) | The battery connection is faulty or a battery is not connected. | Check the battery connection. | Correct the battery connection. | *1 |
| | The battery voltage is lower than the specified value (2.7 V). | Measure the battery voltage. | Replace the battery. | *1 |
| | A failure occurred in the SERVOPACK. | – | The SERVOPACK may be faulty. Replace the SERVOPACK. | – |

Continued on next page.

Continued from previous page.

| Alarm Number: Alarm Name | Possible Cause | Confirmation | Correction | Reference |
|---|---|---|--|-----------|
| A.840: Encoder Data Alarm (Detected at the encoder.) | The encoder malfunctioned. | – | Turn the power supply to the SERVOPACK OFF and ON again. If an alarm still occurs, the Servomotor or linear encoder may be faulty. Replace the Servomotor or linear encoder. | – |
| | An error occurred in reading data from the linear encoder. | – | The linear encoder is not mounted within an appropriate tolerance. Correct the mounting of the linear encoder. | – |
| | Excessive speed occurred in the linear encoder. | – | Control the motor speed within the range specified by the linear encoder manufacturer and then turn ON the control power supply. | – |
| | The encoder malfunctioned due to noise. | – | Correct the wiring around the encoder by separating the Encoder Cable from the Servomotor Main Circuit Cable or by grounding the encoder. | – |
| | The polarity sensor is not wired correctly. | Check the wiring of the polarity sensor. | Correct the wiring of the polarity sensor. | – |
| | The polarity sensor failed. | – | Replace the polarity sensor. | – |
| A.850: Encoder Over-speed (Detected at the encoder when the control power supply is turned ON.) | Rotary Servomotor: The Servomotor speed was 200 min ⁻¹ or higher when the control power supply was turned ON. | Check the motor speed when the power supply is turned ON. | Reduce the Servomotor speed to a value less than 200 min ⁻¹ , and turn ON the control power supply. | – |
| | Linear Servomotor: The Servomotor exceeded the specified speed when the control power supply was turned ON. | Check the motor speed when the power supply is turned ON. | Control the motor speed within the range specified by the linear encoder manufacturer and then turn ON the control power supply. | – |
| | A failure occurred in the encoder. | – | Turn the power supply to the SERVOPACK OFF and ON again. If an alarm still occurs, the Servomotor or linear encoder may be faulty. Replace the Servomotor or linear encoder. | – |
| | A failure occurred in the SERVOPACK. | – | Turn the power supply to the SERVOPACK OFF and ON again. If an alarm still occurs, the SERVOPACK may be faulty. Replace the SERVOPACK. | – |

Continued on next page.

Continued from previous page.

| Alarm Number: Alarm Name | Possible Cause | Confirmation | Correction | Reference |
|--|--|---|--|-----------|
| A.860: Encoder Overheated (Detected when a Rotary Servomotor, Absolute Linear Encoder, or Direct Drive Servomotor is connected. However, this alarm is not detected for SGMCS Servomotors with Incremental Encoders.) (Detected at the encoder.) | The surrounding air temperature around the Servomotor is too high. | Measure the surrounding air temperature around the Servomotor. | Reduce the surrounding air temperature of the Servomotor to 40°C or less. | – |
| | The Servomotor load is greater than the rated load. | Use the accumulated load ratio to check the load. | Operate the Servo Drive so that the motor load remains within the specified range. | *1 |
| | A failure occurred in the encoder. | – | Turn the power supply to the SERVOPACK OFF and ON again. If an alarm still occurs, the Servomotor or absolute linear encoder may be faulty. Replace the Servomotor or absolute linear encoder. | – |
| | A failure occurred in the SERVOPACK. | – | Turn the power supply to the SERVOPACK OFF and ON again. If an alarm still occurs, the SERVOPACK may be faulty. Replace the SERVOPACK. | – |
| A.861: Motor Overheated | The surrounding temperature around the Servomotor is too high. | Measure the surrounding temperature around the Servomotor. | Reduce the surrounding air temperature of the Servomotor to 40° or less. | – |
| | The motor load is greater than the rated load. | Check the load with the accumulated load ratio on the Motion Monitor Tab Page on the SigmaWin+. | Operate the Servo Drive so that the motor load remains within the specified range. | *1 |
| | A failure occurred in the Serial Converter Unit. | – | Turn the power supply to the SERVOPACK OFF and ON again. If an alarm still occurs, the Serial Converter Unit may be faulty. Replace the Serial Converter Unit. | – |
| | A failure occurred in the SERVOPACK. | – | Turn the power supply to the SERVOPACK OFF and ON again. If an alarm still occurs, the SERVOPACK may be faulty. Replace the SERVOPACK. | – |

Continued on next page.

4.2.3 Troubleshooting Alarms

Continued from previous page.

| Alarm Number: Alarm Name | Possible Cause | Confirmation | Correction | Reference |
|---|---|---|---|-----------|
| A.862: Overheat Alarm | The surrounding temperature is too high. | Check the surrounding temperature using a thermometer. | Lower the surrounding temperature by improving the installation conditions of the Linear Servomotor or the machine. | - |
| | The overheat protection input signal line is disconnected or short-circuited. | Check the input voltage with the overheat protection input information on the Motion Monitor Tab Page on the SigmaWin+. | Repair the line for the overheat protection input signal. | - |
| | An overload alarm was reset by turning OFF the power supply too many times. | Check the alarm display to see if there is an overload alarm. | Change the method for resetting the alarm. | - |
| | Operation was performed under an excessive load. | Use the accumulated load ratio to check the load during operation. | Reconsider the load and operating conditions. | - |
| | A failure occurred in the SERVOPACK. | - | The SERVOPACK may be faulty. Replace the SERVOPACK. | - |
| | The temperature detection circuit in the Linear Servomotor is faulty or the sensor attached to the machine is faulty. | - | The temperature detection circuit in the Linear Servomotor may be faulty or the sensor attached to the machine may be faulty. Replace the Linear Servomotor or repair the sensor attached to the machine. | - |
| A.890: Encoder Scale Error | A failure occurred in the linear encoder. | - | The linear encoder may be faulty. Replace the linear encoder. | - |
| A.891: Encoder Module Error | A failure occurred in the linear encoder. | - | Turn the power supply to the SERVOPACK OFF and ON again. If an alarm still occurs, the linear encoder may be faulty. Replace the linear encoder. | - |
| A.8A0: External Encoder Error | Setting the origin of the absolute linear encoder failed because the motor moved. | Before you set the origin, use the fully-closed feedback pulse counter to confirm that the motor is not moving. | The motor must be stopped while setting the origin position. | *1 |
| | A failure occurred in the external encoder. | - | Replace the external encoder. | - |
| A.8A1: External Encoder Module Error | A failure occurred in the external encoder. | - | Replace the external encoder. | - |
| | A failure occurred in the Serial Converter Unit. | - | Replace the Serial Converter Unit. | - |
| A.8A2: External Incremental Encoder Sensor Error | A failure occurred in the external encoder. | - | Replace the external encoder. | - |
| A.8A3: External Absolute Encoder Position Error | A failure occurred in the external absolute encoder. | - | The external absolute encoder may be faulty. Refer to the encoder manufacturer's instruction manual for corrections. | - |

Continued on next page.

Continued from previous page.

| Alarm Number: Alarm Name | Possible Cause | Confirmation | Correction | Reference |
|---|---|--|--|-----------|
| A.8A5: External Encoder Overspeed | An overspeed error was detected in the external encoder. | Check the maximum speed of the external encoder. | Keep the external encoder below its maximum speed. | – |
| A.8A6: External Encoder Overheated | An overheating error was detected in the external encoder. | – | Replace the external encoder. | – |
| A.b33: Current Detection Error 3 | A failure occurred in the current detection circuit. | – | Turn the power supply to the SERVOPACK OFF and ON again. If an alarm still occurs, the SERVOPACK may be faulty. Replace the SERVOPACK. | – |
| A.b6A: MECHATROLINK Communications ASIC Error 1 | There is a fault in the SERVOPACK MECHATROLINK communications section. | – | Turn the power supply to the SERVOPACK OFF and ON again. If an alarm still occurs, the SERVOPACK may be faulty. Replace the SERVOPACK. | – |
| A.b6b: MECHATROLINK Communications ASIC Error 2 | A malfunction occurred in the MECHATROLINK communications section due to noise. | – | Implement the following countermeasures against noise. <ul style="list-style-type: none"> • Check the MECHATROLINK Communications Cable and FG wiring. • Attach a ferrite core to the MECHATROLINK Communications Cable. | – |
| | There is a fault in the SERVOPACK MECHATROLINK communications section. | – | Turn the power supply to the SERVOPACK OFF and ON again. If an alarm still occurs, the SERVOPACK may be faulty. Replace the SERVOPACK. | – |
| A.bF0: System Alarm 0 | A failure occurred in the SERVOPACK. | – | Turn the power supply to the SERVOPACK OFF and ON again. If an alarm still occurs, the SERVOPACK may be faulty. Replace the SERVOPACK. | – |
| A.bF1: System Alarm 1 | A failure occurred in the SERVOPACK. | – | Turn the power supply to the SERVOPACK OFF and ON again. If an alarm still occurs, the SERVOPACK may be faulty. Replace the SERVOPACK. | – |
| A.bF2: System Alarm 2 | A failure occurred in the SERVOPACK. | – | Turn the power supply to the SERVOPACK OFF and ON again. If an alarm still occurs, the SERVOPACK may be faulty. Replace the SERVOPACK. | – |
| A.bF3: System Alarm 3 | A failure occurred in the SERVOPACK. | – | Turn the power supply to the SERVOPACK OFF and ON again. If an alarm still occurs, the SERVOPACK may be faulty. Replace the SERVOPACK. | – |

Continued on next page.

4.2.3 Troubleshooting Alarms

Continued from previous page.

| Alarm Number: Alarm Name | Possible Cause | Confirmation | Correction | Reference |
|--|--|--------------------------------------|---|-----------|
| A.bF4: System Alarm 4 | A failure occurred in the SERVOPACK. | — | Turn the power supply to the SERVOPACK OFF and ON again. If an alarm still occurs, the SERVOPACK may be faulty. Replace the SERVOPACK. | — |
| A.bF5: System Alarm 5 | A failure occurred in the SERVOPACK. | — | Turn the power supply to the SERVOPACK OFF and ON again. If an alarm still occurs, the SERVOPACK may be faulty. Replace the SERVOPACK. | — |
| A.bF6: System Alarm 6 | A failure occurred in the SERVOPACK. | — | Turn the power supply to the SERVOPACK OFF and ON again. If an alarm still occurs, the SERVOPACK may be faulty. Replace the SERVOPACK. | — |
| A.bF7: System Alarm 7 | A failure occurred in the SERVOPACK. | — | Turn the power supply to the SERVOPACK OFF and ON again. If an alarm still occurs, the SERVOPACK may be faulty. Replace the SERVOPACK. | — |
| A.bF8: System Alarm 8 | A failure occurred in the SERVOPACK. | — | Turn the power supply to the SERVOPACK OFF and ON again. If an alarm still occurs, the SERVOPACK may be faulty. Replace the SERVOPACK. | — |
| A.C10: Servomotor Out of Control (Detected when the servo is turned ON.) | The order of phases U, V, and W in the motor wiring is not correct. | Check the Servomotor wiring. | Make sure that the Servomotor is correctly wired. | — |
| | There is an error in the setting of Pn080 = n.□□X□ (Motor Phase Sequence Selection). | Check the setting of Pn080 = n.□□X□. | Set Pn080 = n.□□X□ to an appropriate value. | *1 |
| | A failure occurred in the encoder. | — | If the motor wiring is correct and an alarm still occurs after turning the power supply OFF and ON again, the Servomotor or linear encoder may be faulty. Replace the Servomotor or linear encoder. | — |
| | A failure occurred in the SERVOPACK. | — | Turn the power supply to the SERVOPACK OFF and ON again. If an alarm still occurs, the SERVOPACK may be faulty. Replace the SERVOPACK. | — |

Continued on next page.

Continued from previous page.

| Alarm Number: Alarm Name | Possible Cause | Confirmation | Correction | Reference |
|---|--|--|--|-----------|
| A.C20: Phase Detection Error | The linear encoder signal level is too low. | Check the voltage of the linear encoder signal. | Fine-tune the mounting of the scale head. Or, replace the linear encoder. | – |
| | The count-up direction of the linear encoder does not match the forward direction of the Moving Coil in the motor. | Check the setting of Pn080 = n.□□X□ (Motor Phase Sequence Selection). Check the installation orientation for the linear encoder and Moving Coil. | Change the setting of Pn080 = n.□□X□. Correctly reinstall the linear encoder or Moving Coil. | *1 |
| | The polarity sensor signal is being affected by noise. | – | Correct the FG wiring. Implement countermeasures against noise for the polarity sensor wiring. | – |
| | The setting of Pn282 (Linear Encoder Scale Pitch) is not correct. | Check the setting of Pn282 (Linear Encoder Scale Pitch). | Check the specifications of the linear encoder and set a correct value. | *1 |
| A.C21: Polarity Sensor Error | The polarity sensor is protruding from the Magnetic Way of the motor. | Check the polarity sensor. | Correctly reinstall the Moving Coil or Magnetic Way of the motor. | – |
| | The polarity sensor is not wired correctly. | Check the wiring of the polarity sensor. | Correct the wiring of the polarity sensor. | – |
| | The polarity sensor failed. | – | Replace the polarity sensor. | – |
| A.C22: Phase Information Disagreement | The SERVOPACK phase information is different from the linear encoder phase information. | – | Perform polarity detection. | *1 |

Continued on next page.

Continued from previous page.

| Alarm Number: Alarm Name | Possible Cause | Confirmation | Correction | Reference |
|--------------------------------------|--|--|--|-----------|
| A.C50: Polarity Detection Failure | The parameter settings are not correct. | Check the linear encoder specifications and feedback signal status. | The settings of Pn282 (Linear Encoder Scale Pitch) and Pn080 = n.□□X□ (Motor Phase Sequence Selection) may not match the installation. Set the parameters to correct values. | *1 |
| | There is noise on the scale signal. | Check to make sure that the frame grounds of the Serial Converter Unit and Servomotor are connected to the FG terminal on the SERVOPACK and that the FG terminal on the SERVOPACK is connected to the frame ground on the power supply. And, confirm that the shield is properly processed on the Linear Encoder Cable. Check to see if the detection reference is repeatedly output in one direction. | Implement appropriate countermeasures against noise for the Linear Encoder Cable. | - |
| | An external force was applied to the Moving Coil of the motor. | - | The polarity cannot be properly detected if the detection reference is 0 and the speed feedback is not 0 because of an external force, such as cable tension, applied to the Moving Coil. Implement measures to reduce the external force so that the speed feedback goes to 0. If the external force cannot be reduced, increase the setting of Pn481 (Polarity Detection Speed Loop Gain). | - |
| | The linear encoder resolution is too low. | Check the linear encoder scale pitch to see if it is within 100 μm. | If the linear encoder scale pitch is 100 μm or higher, the SERVOPACK cannot detect the correct speed feedback. Use a linear encoder scale pitch with higher resolution. (We recommend a pitch of 40 μm or less.) Or, increase the setting of Pn485 (Polarity Detection Reference Speed). However, increasing the setting of Pn485 will increase the Servomotor movement range that is required for polarity detection. | - |

Continued on next page.

Continued from previous page.

| Alarm Number: Alarm Name | Possible Cause | Confirmation | Correction | Reference |
|--|--|--------------------------------|---|-----------|
| A.C51: Overtravel Detected during Polarity Detection | The overtravel signal was detected during polarity detection. | Check the overtravel position. | Wire the overtravel signals. Execute polarity detection at a position where an overtravel signal would not be detected. | *1 |
| A.C52: Polarity Detection Not Completed | The servo was turned ON when using an absolute linear encoder, Pn587 was set to n.□□□0 (Do not detect polarity), and the polarity had not been detected. | — | When using an absolute linear encoder, set Pn587 to n.□□□1 (Detect polarity). | — |
| A.C53: Out of Range of Motion for Polarity Detection | The travel distance exceeded the setting of Pn48E (Polarity Detection Range) in the middle of detection. | — | Increase the setting of Pn48E (Polarity Detection Range). Or, increase the setting of Pn481 (Polarity Detection Speed Loop Gain). | — |
| A.C54: Polarity Detection Failure 2 | An external force was applied to the Servomotor. | — | Increase the setting of Pn495 (Polarity Detection Confirmation Force Reference). Increase the setting of Pn498 (Polarity Detection Allowable Error Range). Increasing the allowable error will also increase the motor temperature. | — |
| A.C80: Encoder Clear Error or Multiturn Limit Setting Error | A failure occurred in the encoder. | — | Turn the power supply to the SERVOPACK OFF and ON again. If an alarm still occurs, the Servomotor or linear encoder may be faulty. Replace the Servomotor or linear encoder. | — |
| | A failure occurred in the SERVOPACK. | — | Turn the power supply to the SERVOPACK OFF and ON again. If an alarm still occurs, the SERVOPACK may be faulty. Replace the SERVOPACK. | — |

Continued on next page.

4.2.3 Troubleshooting Alarms

Continued from previous page.

| Alarm Number: Alarm Name | Possible Cause | Confirmation | Correction | Reference |
|---|---|--|--|-----------|
| A.C90: Encoder Commu- nications Error | There is a faulty contact in the connector or the connector is not wired correctly for the encoder. | Check the condition of the encoder connector. | Reconnect the encoder connector and check the encoder wiring. | *1 |
| | There is a cable disconnection or short-circuit in the encoder. Or, the cable impedance is outside the specified values. | Check the condition of the Encoder Cable. | Use the Encoder Cable within the specified specifications. | - |
| | One of the following has occurred: corrosion caused by improper temperature, humidity, or gas, a short-circuit caused by entry of water drops or cutting oil, or faulty contact in connector caused by vibration. | Check the operating environment. | Improve the operating environment, and replace the cable. If the alarm still occurs, replace the SERVOPACK. | *1 |
| | A malfunction was caused by noise. | - | Correct the wiring around the encoder by separating the Encoder Cable from the Servomotor Main Circuit Cable or by grounding the encoder. | *1 |
| | A failure occurred in the SERVOPACK. | - | Connect the Servomotor to another SERVOPACK, and turn ON the control power supply. If no alarm occurs, the SERVOPACK may be faulty. Replace the SERVOPACK. | - |
| A.C91: Encoder Commu- nications Position Data Acceleration Rate Error | Noise entered on the signal lines because the Encoder Cable is bent or the sheath is damaged. | Check the condition of the Encoder Cable and connectors. | Check the Encoder Cable to see if it is installed correctly. | *1 |
| | The Encoder Cable is bundled with a high-current line or installed near a high-current line. | Check the installation condition of the Encoder Cable. | Confirm that there is no surge voltage on the Encoder Cable. | - |
| | There is variation in the FG potential because of the influence of machines on the Servomotor side, such as a welder. | Check the installation condition of the Encoder Cable. | Properly ground the machine to separate it from the FG of the encoder. | - |

Continued on next page.

Continued from previous page.

| Alarm Number: Alarm Name | Possible Cause | Confirmation | Correction | Reference |
|--|--|---------------------------------|--|-----------|
| A.C92: Encoder Commu- nications Timer Error | Noise entered on the signal line from the encoder. | – | Implement countermeasures against noise for the encoder wiring. | *1 |
| | Excessive vibration or shock was applied to the encoder. | Check the operating conditions. | Reduce machine vibration. Correctly install the Servomotor or linear encoder. | – |
| | A failure occurred in the encoder. | – | Turn the power supply to the SERVOPACK OFF and ON again. If an alarm still occurs, the Servomotor or linear encoder may be faulty. Replace the Servomotor or linear encoder. | – |
| | A failure occurred in the SERVOPACK. | – | Turn the power supply to the SERVOPACK OFF and ON again. If an alarm still occurs, the SERVOPACK may be faulty. Replace the SERVOPACK. | – |
| A.CA0: Encoder Parame- ter Error | A failure occurred in the encoder. | – | Turn the power supply to the SERVOPACK OFF and ON again. If an alarm still occurs, the Servomotor or linear encoder may be faulty. Replace the Servomotor or linear encoder. | – |
| | A failure occurred in the SERVOPACK. | – | Turn the power supply to the SERVOPACK OFF and ON again. If an alarm still occurs, the SERVOPACK may be faulty. Replace the SERVOPACK. | – |

Continued on next page.

4.2.3 Troubleshooting Alarms

Continued from previous page.

| Alarm Number: Alarm Name | Possible Cause | Confirmation | Correction | Reference |
|---|--|--|--|-----------|
| A.Cb0: Encoder Echo- back Error | The encoder is wired incorrectly or there is faulty contact. | Check the wiring of the encoder. | Make sure that the encoder is correctly wired. | *1 |
| | The specifications of the Encoder Cable are not correct and noise entered on it. | – | Use a shielded twisted-pair wire cable or a screened twisted-pair cable with conductors of at least 0.12 mm ² . | – |
| | The Encoder Cable is too long and noise entered on it. | – | <ul style="list-style-type: none"> Rotary Servomotors: The Encoder Cable wiring distance must be 50 m max. Linear Servomotors: The Encoder Cable wiring distance must be 20 m max. | – |
| | There is variation in the FG potential because of the influence of machines on the Servomotor side, such as a welder. | Check the condition of the Encoder Cable and connectors. | Properly ground the machine to separate it from the FG of the encoder. | – |
| | Excessive vibration or shock was applied to the encoder. | Check the operating conditions. | Reduce machine vibration. Correctly install the Servomotor or linear encoder. | – |
| | A failure occurred in the encoder. | – | Turn the power supply to the SERVOPACK OFF and ON again. If an alarm still occurs, the Servomotor or linear encoder may be faulty. Replace the Servomotor or linear encoder. | – |
| | A failure occurred in the SERVOPACK. | – | Turn the power supply to the SERVOPACK OFF and ON again. If an alarm still occurs, the SERVOPACK may be faulty. Replace the SERVOPACK. | – |
| A.CC0: Multiturn Limit Disagreement | When using a Direct Drive Servomotor, the setting of Pn205 (Multiturn Limit) does not agree with the encoder. | Check the setting of Pn205. | Correct the setting of Pn205 (0 to 65,535). | *1 |
| | The multiturn limit of the encoder is different from that of the SERVOPACK. Or, the multiturn limit of the SERVOPACK has been changed. | Check the setting of Pn205 in the SERVOPACK. | Change the setting if the alarm occurs. | *1 |
| | A failure occurred in the SERVOPACK. | – | Turn the power supply to the SERVOPACK OFF and ON again. If an alarm still occurs, the SERVOPACK may be faulty. Replace the SERVOPACK. | – |

Continued on next page.

Continued from previous page.

| Alarm Number: Alarm Name | Possible Cause | Confirmation | Correction | Reference |
|---|--|--|--|-----------|
| A.CF1: Reception Failed Error in Feed- back Option Module Commu- nications | The cable between the Serial Converter Unit and SERVOPACK is not wired correctly or there is a faulty contact. | Check the wiring of the external encoder. | Correctly wire the cable between the Serial Converter Unit and SERVOPACK. | *1 |
| | A specified cable is not being used between Serial Converter Unit and SERVOPACK. | Check the wiring specifications of the external encoder. | Use a specified cable. | - |
| | The cable between the Serial Converter Unit and SERVOPACK is too long. | Measure the length of the cable that connects the Serial Converter Unit. | The length of the cable between the Serial Converter Unit and SERVOPACK must be 20 m or less. | - |
| | The sheath on cable between the Serial Converter Unit and SERVOPACK is broken. | Check the cable that connects the Serial Converter Unit. | Replace the cable between the Serial Converter Unit and SERVOPACK. | - |
| A.CF2: Timer Stopped Error in Feed- back Option Module Commu- nications | Noise entered the cable between the Serial Converter Unit and SERVOPACK. | - | Correct the wiring around the Serial Converter Unit, e.g., separate I/O signal lines from the Main Circuit Cables or ground. | - |
| | A failure occurred in the Serial Converter Unit. | - | Replace the Serial Converter Unit. | - |
| | A failure occurred in the SERVOPACK. | - | Replace the SERVOPACK. | - |
| A.d00: Position Deviation Overflow (The setting of Pn520 (Position Deviation Overflow Alarm Level) was exceeded by the position deviation while the servo was ON.) | The Servomotor U, V, and W wiring is not correct. | Check the wiring of the Servomotor's Main Circuit Cables. | Make sure that there are no faulty contacts in the wiring for the Servomotor and encoder. | - |
| | The position command speed is too fast. | Reduce the position command speed and try operating the SERVOPACK. | Reduce the position reference speed or the reference acceleration rate, or reconsider the electronic gear ratio. | *1 |
| | The acceleration of the position reference is too high. | Reduce the reference acceleration and try operating the SERVOPACK. | Reduce the acceleration of the position reference using a MECHATROLINK command. Or, smooth the position reference acceleration by selecting the position reference filter (ACCFIL) using a MECHATROLINK command. | - |
| | The setting of Pn520 (Position Deviation Overflow Alarm Level) is too low for the operating conditions. | Check Pn520 (Position Deviation Overflow Alarm Level) to see if it is set to an appropriate value. | Optimize the setting of Pn520. | *1 |
| | A failure occurred in the SERVOPACK. | - | Turn the power supply to the SERVOPACK OFF and ON again. If an alarm still occurs, the SERVOPACK may be faulty. Replace the SERVOPACK. | - |

Continued on next page.

Continued from previous page.

| Alarm Number: Alarm Name | Possible Cause | Confirmation | Correction | Reference |
|---|--|--|--|-----------|
| A.d01: Position Deviation Overflow Alarm at Servo ON | The servo was turned ON after the position deviation exceeded the setting of Pn526 (Position Deviation Overflow Alarm Level at Servo ON) while the servo was OFF. | Check the position deviation while the servo is OFF. | Optimize the setting of Pn526 (Position Deviation Overflow Alarm Level at Servo ON). | *1 |
| A.d02: Position Deviation Overflow Alarm for Speed Limit at Servo ON | If position deviation remains in the deviation counter, the setting of Pn529 or Pn584 (Speed Limit Level at Servo ON) limits the speed when the servo is turned ON. This alarm occurs if a position reference is input and the setting of Pn520 (Position Deviation Overflow Alarm Level) is exceeded. | – | Optimize the setting of Pn520 (Position Deviation Overflow Alarm Level). Or, adjust the setting of Pn529 or Pn584 (Speed Limit Level at Servo ON). | *1 |
| A.d10: Motor-Load Position Deviation Overflow | The motor direction and external encoder installation orientation are backward. | Check the motor direction and the external encoder installation orientation. | Install the external encoder in the opposite direction, or change the setting of Pn002 = n.X□□□ (External Encoder Usage) to reverse the direction. | *1 |
| | There is an error in the connection between the load (e.g., stage) and external encoder coupling. | Check the coupling of the external encoder. | Check the mechanical coupling. | – |
| A.d30: Position Data Overflow | The position data exceeded $\pm 1,879,048,192$. | Check the input reference pulse counter. | Reconsider the operating specifications. | – |
| A.E02: MECHATROLINK Internal Synchronization Error 1 | The MECHATROLINK transmission cycle fluctuated. | – | Remove the cause of transmission cycle fluctuation at the host controller. | – |
| | A failure occurred in the SERVOPACK. | – | Turn the power supply to the SERVOPACK OFF and ON again. If an alarm still occurs, the SERVOPACK may be faulty. Replace the SERVOPACK. | – |
| A.E40: MECHATROLINK Transmission Cycle Setting Error | The setting of MECHATROLINK transmission cycle is outside of the specified range. | Check the setting of the MECHATROLINK transmission cycle. | Set the MECHATROLINK transmission cycle to an appropriate value. | – |
| A.E41: MECHATROLINK Communications Data Size Setting Error | The number of transmission bytes set on DIP switch S3 is not correct. | Check the MECHATROLINK communications data size of the host controller. | Reset DIP switch S3 to change the number of transmission bytes to an appropriate value. | *1 |

Continued on next page.

Continued from previous page.

| Alarm Number: Alarm Name | Possible Cause | Confirmation | Correction | Reference |
|--|---|---|---|-----------|
| A.E42: MECHATROLINK Station Address Setting Error | The station address is outside of the setting range. | Check rotary switches S1 and S2 to see if the station address is between 03 and EF. | Check the setting of the station address of the host controller, and reset rotary switches S1 and S2 to change the address to an appropriate value between 03 and EF. | *1 |
| | Two or more stations on the communications network have the same address. | Check to see if two or more stations on the communications network have the same address. | Check the setting of the station address of the host controller, and reset rotary switches S1 and S2 to change the address to an appropriate value between 03 and EF. | *1 |
| A.E50*4: MECHATROLINK Synchronization Error | The WDT data in the host controller was not updated normally. | Check to see if the WDT data is being updated at the host controller. | Correctly update the WDT data at the host controller. | – |
| | A failure occurred in the SERVOPACK. | – | Turn the power supply to the SERVOPACK OFF and ON again. If an alarm still occurs, the SERVOPACK may be faulty. Replace the SERVOPACK. | – |
| A.E51: MECHATROLINK Synchronization Failed | The WDT data at the host controller was not updated correctly at the start of synchronous communications, so synchronous communications could not be started. | Check to see if the WDT data is being updated in the host controller. | Correctly update the WDT data at the host controller. | – |
| | A failure occurred in the SERVOPACK. | – | Turn the power supply to the SERVOPACK OFF and ON again. If an alarm still occurs, the SERVOPACK may be faulty. Replace the SERVOPACK. | – |
| A.E60*4: Reception Error in MECHATROLINK Communications | MECHATROLINK wiring is not correct. | Check the MECHATROLINK wiring. | Correct the MECHATROLINK Communications Cable wiring. | – |
| | A MECHATROLINK data reception error occurred due to noise. | – | Implement countermeasures against noise. (Check the MECHATROLINK Communications Cable and FG wiring, and implement measures such as attaching a ferrite core to the MECHATROLINK Communications Cable.) | – |
| | A failure occurred in the SERVOPACK. | – | Turn the power supply to the SERVOPACK OFF and ON again. If an alarm still occurs, the SERVOPACK may be faulty. Replace the SERVOPACK. | – |

Continued on next page.

Continued from previous page.

| Alarm Number: Alarm Name | Possible Cause | Confirmation | Correction | Reference |
|---|--|--|---|-----------|
| A.E61: Synchronization Interval Error in MECHATROLINK Transmission Cycle | The MECHATROLINK transmission cycle fluctuated. | Check the setting of the MECHATROLINK transmission cycle. | Remove the cause of transmission cycle fluctuation at the host controller. | – |
| | A failure occurred in the SERVOPACK. | – | Turn the power supply to the SERVOPACK OFF and ON again. If an alarm still occurs, the SERVOPACK may be faulty. Replace the SERVOPACK. | – |
| A.E63: MECHATROLINK Synchronization Frame Not Received | MECHATROLINK wiring is not correct. | Check the Servomotor wiring. | Correct the MECHATROLINK Communications Cable wiring. | – |
| | A MECHATROLINK data reception error occurred due to noise. | – | Implement countermeasures against noise. (Check the MECHATROLINK Communications Cable and FG wiring, and implement measures such as attaching a ferrite core to the MECHATROLINK Communications Cable.) | – |
| | A failure occurred in the SERVOPACK. | – | Turn the power supply to the SERVOPACK OFF and ON again. If an alarm still occurs, the SERVOPACK may be faulty. Replace the SERVOPACK. | – |
| A.E71: Safety Option Module Detection Failure | There is a faulty connection between the SERVOPACK and the Safety Option Module. | Check the connection between the SERVOPACK and the Safety Option Module. | Correctly connect the Safety Option Module. | – |
| | The Safety Option Module was disconnected. | – | Execute Fn014 (Reset Option Module Configuration Error) from the Digital Operator or SigmaWin+ and then turn the power supply to the SERVOPACK OFF and ON again. | *1 |
| | A failure occurred in the Safety Option Module. | – | Replace the Safety Option Module. | – |
| | A failure occurred in the SERVOPACK. | – | Replace the SERVOPACK. | – |
| A.E72: Feedback Option Module Detection Failure | There is a faulty connection between the SERVOPACK and the Feedback Option Module. | Check the connection between the SERVOPACK and the Feedback Option Module. | Correctly connect the Feedback Option Module. | – |
| | The Feedback Option Module was disconnected. | – | Reset the Option Module configuration error and turn the power supply to the SERVOPACK OFF and ON again. | *1 |
| | A failure occurred in the Feedback Option Module. | – | Replace the Feedback Option Module. | – |
| | A failure occurred in the SERVOPACK. | – | Replace the SERVOPACK. | – |

Continued on next page.

Continued from previous page.

| Alarm Number: Alarm Name | Possible Cause | Confirmation | Correction | Reference |
|--|--|---|--|-----------|
| A.E74: Unsupported Safety Option Module | A failure occurred in the Safety Option Module. | – | Replace the Safety Option Module. | – |
| | An unsupported Safety Option Module was connected. | Refer to the catalog of the connected Safety Option Module. | Connect a compatible Safety Option Module. | – |
| A.Eb1: Safety Function Signal Input Tim- ing Error | The delay between activation of the /HWBB1 and /HWBB2 input signals for the HWBB was ten second or longer. | Measure the time delay between the /HWBB1 and /HWBB2 signals. | The output signal circuits or devices for /HWBB1 and /HWBB2 or the SERVOPACK input signal circuits may be faulty. Alternatively, the input signal cables may be disconnected. Check to see if any of these items are faulty or have been disconnected. | – |
| | A failure occurred in the SERVOPACK. | – | Replace the SERVOPACK. | – |
| A.EC8: Gate Drive Error 1 (An error occurred in the gate drive circuit.) | A failure occurred in the SERVOPACK. | – | Turn the power supply to the SERVOPACK OFF and ON again. If an alarm still occurs, the SERVOPACK may be faulty. Replace the SERVOPACK. | – |
| A.EC9: Gate Drive Error 2 (An error occurred in the gate drive circuit.) | | | | |
| A.Ed1: Command Exe- cution Timeout | A timeout error occurred for a MECHATROLINK command. | Check the motor status when the command is executed. | Execute the SV_ON or SENS_ON command only when the motor is not operating. | – |
| | | <ul style="list-style-type: none"> For fully-closed loop control, check the status of the external encoder when the command is executed. For other types of control, check the status of the linear encoder when the command is executed. | Execute the SENS_ON command only when an external encoder (e.g., a linear encoder) is connected. | – |

Continued on next page.

Continued from previous page.

| Alarm Number: Alarm Name | Possible Cause | Confirmation | Correction | Reference |
|---|---|---|--|-----------|
| A.F10: Power Supply Line Open Phase (The voltage was low for more than one second for phase R, S, or T when the main power supply was ON.) | The three-phase power supply wiring is not correct. | Check the power supply wiring. | Make sure that the power supply is correctly wired. | *1 |
| | The three-phase power supply is unbalanced. | Measure the voltage for each phase of the three-phase power supply. | Balance the power supply by changing phases. | - |
| | A single-phase power supply was input without specifying a signal-phase AC power supply input (Pn00B = n.□1□□). | Check the power supply and the parameter setting. | Match the parameter setting to the power supply. | *1 |
| | A failure occurred in the SERVOPACK. | - | Turn the power supply to the SERVOPACK OFF and ON again. If an alarm still occurs, the SERVOPACK may be faulty. Replace the SERVOPACK. | - |
| FL-1*6: System Alarm | A failure occurred in the SERVOPACK. | - | Turn the power supply to the SERVOPACK OFF and ON again. If an alarm still occurs, the SERVOPACK may be faulty. Replace the SERVOPACK. | - |
| FL-2*6: System Alarm | | | | |
| FL-3*6: System Alarm | | | | |
| FL-4*6: System Alarm | | | | |
| FL-5*6: System Alarm | | | | |
| FL-6*6: System Alarm | | | | |
| CPF00: Digital Operator Communications Error 1 | There is a faulty connection between the Digital Operator and the SERVOPACK. | Check the connector contact. | Disconnect the connector and insert it again. Or, replace the cable. | - |
| | A malfunction was caused by noise. | - | Keep the Digital Operator or the cable away from sources of noise. | - |
| CPF01: Digital Operator Communications Error 2 | A failure occurred in the Digital Operator. | - | Disconnect the Digital Operator and then connect it again. If an alarm still occurs, the Digital Operator may be faulty. Replace the Digital Operator. | - |
| | A failure occurred in the SERVOPACK. | - | Turn the power supply to the SERVOPACK OFF and ON again. If an alarm still occurs, the SERVOPACK may be faulty. Replace the SERVOPACK. | - |

*1. Refer to the following manual for details.

 Σ -7-Series Σ -7S SERVOPACK with MECHATROLINK-III Communications References Product Manual (Manual No.: SIEP S800001 28)

*2. Detection Conditions

• Rotary Servomotor

If either of the following conditions is detected, an alarm will occur.

$$\bullet \text{ Pn533 [min}^{-1}\text{]} \times \frac{\text{Encoder resolution}}{6 \times 10^5} \leq \frac{\text{Pn20E}}{\text{Pn210}}$$

$$\bullet \text{ Maximum motor speed [min}^{-1}\text{]} \times \frac{\text{Encoder resolution}}{\text{Approx. } 3.66 \times 10^{12}} \geq \frac{\text{Pn20E}}{\text{Pn210}}$$

• Linear Servomotor

If either of the following conditions is detected, an alarm will occur.

$$\bullet \frac{\text{Pn585 [mm/s]}}{\text{Linear encoder pitch [\mu m]}} \times \frac{\text{Resolution of Serial Converter Unit}}{10} \leq \frac{\text{Pn20E}}{\text{Pn210}}$$

$$\bullet \frac{\text{Pn385 [100 mm/s]}}{\text{Linear encoder pitch [\mu m]}} \times \frac{\text{Resolution of Serial Converter Unit}}{\text{Approx. } 6.10 \times 10^5} \geq \frac{\text{Pn20E}}{\text{Pn210}}$$

*3. Detection Conditions

• Rotary Servomotor

If either of the following conditions is detected, an alarm will occur.

$$\bullet \text{ Rated motor speed [min}^{-1}\text{]} \times 1/3 \times \frac{\text{Encoder resolution}}{6 \times 10^5} \leq \frac{\text{Pn20E}}{\text{Pn210}}$$

$$\bullet \text{ Maximum motor speed [min}^{-1}\text{]} \times \frac{\text{Encoder resolution}}{\text{Approx. } 3.66 \times 10^{12}} \geq \frac{\text{Pn20E}}{\text{Pn210}}$$

• Linear Servomotor

If either of the following conditions is detected, an alarm will occur.

$$\bullet \frac{\text{Rated motor speed [mm/s]} \times 1/3}{\text{Linear encoder pitch [\mu m]}} \times \frac{\text{Resolution of Serial Converter Unit}}{10} \leq \frac{\text{Pn20E}}{\text{Pn210}}$$

$$\bullet \frac{\text{Pn385 [100 mm/s]}}{\text{Linear encoder pitch [\mu m]}} \times \frac{\text{Resolution of Serial Converter Unit}}{\text{Approx. } 6.10 \times 10^5} \geq \frac{\text{Pn20E}}{\text{Pn210}}$$

*4. Refer to the following manual for details.

 Σ -7-Series Peripheral Device Selection Manual (Manual No.: SIEP S800001 32)

*5. The SERVOPACK will fail if the External Regenerative Resistor or Regenerative Resistor Unit is connected while the jumper is connected between the B2 and B3 terminals.

*6. These alarms are not stored in the alarm history. They are only displayed on the panel display.

4.2.4 Warning Displays

If a warning occurs in the SERVOPACK, a warning number will be displayed on the panel display. Warnings are displayed to warn you before an alarm occurs.

4.2.5 List of Warnings

The list of warnings gives the warning name and warning meaning in order of the warning numbers.

| Warning Number | Warning Name | Meaning | Resetting |
|----------------|--|--|-----------------------|
| A.900 | Position Deviation Overflow | The position deviation exceeded the percentage set with the following formula: (Pn520 × Pn51E/100) | Required. |
| A.901 | Position Deviation Overflow Alarm at Servo ON | The position deviation when the servo was turned ON exceeded the percentage set with the following formula: (Pn526 × Pn528/100) | Required. |
| A.910 | Overload | This warning occurs before an overload alarm (A.710 or A.720) occurs. If the warning is ignored and operation is continued, an alarm may occur. | Required. |
| A.911 | Vibration | Abnormal vibration was detected during motor operation. The detection level is the same as A.520. Set whether to output an alarm or a warning by setting Pn310 (Vibration Detection Selections). | Required. |
| A.912 | Internal Temperature Warning 1 (Control Board Temperature Error) | The surrounding temperature of the control PCB is abnormal. | Required. |
| A.913 | Internal Temperature Warning 2 (Power Board Temperature Error) | The surrounding temperature of the power PCB is abnormal. | Required. |
| A.920 | Regenerative Overload | This warning occurs before an A.320 alarm (Regenerative Overload) occurs. If the warning is ignored and operation is continued, an alarm may occur. | Required. |
| A.921 | Dynamic Brake Overload | This warning occurs before an A.731 alarm (Dynamic Brake Overload) occurs. If the warning is ignored and operation is continued, an alarm may occur. | Required. |
| A.923 | SERVOPACK Built-in Fan Stopped | The fan inside the SERVOPACK stopped. | Required. |
| A.930 | Absolute Encoder Battery Error | This warning occurs when the voltage of absolute encoder's battery is low. | Required. |
| A.93B | Overheat Warning | The input voltage (temperature) for the overheat protection input (TH) signal exceeded the setting of Pn61C (Overheat Warning Level). | Required. |
| A.942 | Speed Ripple Compensation Information Disagreement | The speed ripple compensation information stored in the encoder does not agree with the speed ripple compensation information stored in the SERVOPACK. | Required. |
| A.94A | Data Setting Warning 1 (Parameter Number Error) | There is an error in the parameter number for a Data Setting Warning 1 (Parameter Number) command. | Automatically reset.* |
| A.94b | Data Setting Warning 2 (Out of Range) | The command data is out of range. | Automatically reset.* |
| A.94C | Data Setting Warning 3 (Calculation Error) | A calculation error was detected. | Automatically reset.* |
| A.94d | Data Setting Warning 4 (Parameter Size) | The data sizes do not match. | Automatically reset.* |
| A.94E | Data Setting Warning 5 (Latch Mode Error) | A latch mode error was detected. | Required. |
| A.95A | Command Warning 1 (Unsatisfied Command Conditions) | A command was sent when the conditions for sending a command were not satisfied. | Automatically reset.* |

Continued on next page.

Continued from previous page.

| Warning Number | Warning Name | Meaning | Resetting |
|----------------|---|--|-----------------------|
| A.95b | Command Warning 2 (Unsupported Command) | An unsupported command was sent. | Automatically reset.* |
| A.95d | Command Warning 4 (Command Interference) | There was command interference, particularly latch command interference. | Automatically reset.* |
| A.95E | Command Warning 5 (Subcommand Not Possible) | The subcommand and main command interfere with each other. | Automatically reset.* |
| A.95F | Command Warning 6 (Undefined Command) | An undefined command was sent. | Automatically reset.* |
| A.960 | MECHATROLINK Communications Warning | A communications error occurred during MECHATROLINK communications. | Required. |
| A.971 | Undervoltage | This warning occurs before an A.410 alarm (Undervoltage) occurs. If the warning is ignored and operation is continued, an alarm may occur. | Required. |
| A.97A | Command Warning 7 (Phase Error) | A command that cannot be executed in the current phase was sent. | Automatically reset.* |
| A.97b | Data Clamp Out of Range | The set command data was clamped to the minimum or maximum value of the allowable setting range. | Automatically reset.* |
| A.9A0 | Overtravel | Overtravel was detected while the servo was ON. | Required. |
| A.9b0 | Preventative Maintenance Warning | One of the consumable parts has reached the end of its service life. | Required. |

* If using the commands for the MECHATROLINK-III standard servo profile, the warning will automatically be cleared after the correct command is received. If you use MECHATROLINK-II-compatible profile commands, send an ALM_CLR (Clear Warning or Alarm) command to clear the warning.

Note: Use Pn008 = n.□X□□ (Warning Detection Selection) to control warning detection.

However, the following warnings are not affected by the setting of Pn008 = n.□X□□ and other parameter settings are required in addition to Pn008 = n.□X□□.

| Warning | Parameters That Must Be Set to Select Warning Detection |
|-----------------------------------|--|
| A.911 | Pn310 = n.□□□X (Vibration Detection Selection) |
| A.923 | – (Not affected by the setting of Pn008 = n.□X□□.) |
| A.930 | Pn008 = n.□□□X (Low Battery Voltage Alarm/Warning Selection) |
| A.942 | Pn423 = n.□□X□ (Speed Ripple Compensation Information Disagreement Warning Detection Selection) |
| A.94A to A.960 and A.97A to A.97b | Pn800=n.□□X□ (Warning Check Masks) |
| A.971 | Pn008 = n.□□□X (Low Battery Voltage Alarm/Warning Selection) (Not affected by the setting of Pn008 = n.□X□□.) |
| A.9A0 | Pn00D = n.X□□□ (Overtravel Warning Detection Selection) (Not affected by the setting of Pn008 = n.□X□□.) |
| A.9b0 | Pn00F = n.□□□X (Preventative Maintenance Warning Selection) |

4.2.6 Troubleshooting Warnings

The causes of and corrections for the warnings are given in the following table. Contact your Yaskawa representative if you cannot solve a problem with the correction given in the table.

| Warning Number: Warning Name | Possible Cause | Confirmation | Correction | Reference |
|---|--|---|--|-----------|
| A.900: Position Deviation Overflow | The Servomotor U, V, and W wiring is not correct. | Check the wiring of the Servomotor's Main Circuit Cables. | Make sure that there are no faulty connections in the wiring for the Servomotor and encoder. | - |
| | A SERVOPACK gain is too low. | Check the SERVO-PACK gains. | Increase the servo gain, e.g., by using autotuning without a host reference. | * |
| | The acceleration of the position reference is too high. | Reduce the reference acceleration and try operating the SERVO-PACK. | Reduce the acceleration of the position reference using a MECHATROLINK command. Or, smooth the position reference acceleration by selecting the position reference filter (ACCFIL) using a MECHATROLINK command. | - |
| | The excessive position deviation alarm level (Pn520 × Pn51E/100) is too low for the operating conditions. | Check excessive position deviation alarm level (Pn520 × Pn51E/100) to see if it is set to an appropriate value. | Optimize the settings of Pn520 and Pn51E. | * |
| | A failure occurred in the SERVO-PACK. | - | Turn the power supply to the SERVOPACK OFF and ON again. If an alarm still occurs, the SERVOPACK may be faulty. Replace the SERVOPACK. | - |
| A.901: Position Deviation Overflow Alarm at Servo ON | The position deviation when the servo was turned ON exceeded the percentage set with the following formula: (Pn526 × Pn528/100) | - | Optimize the setting of Pn528 (Position Deviation Overflow Warning Level at Servo ON). | - |

Continued on next page.

Continued from previous page.

| Warning Number: Warning Name | Possible Cause | Confirmation | Correction | Reference |
|--|--|--|--|-----------|
| A.910: Overload (warning before an A.710 or A.720 alarm occurs) | The wiring is not correct or there is a faulty connection in the motor or encoder wiring. | Check the wiring. | Make sure that the Servomotor and encoder are correctly wired. | – |
| | Operation was performed that exceeded the overload protection characteristics. | Check the motor overload characteristics and Run command. | Reconsider the load and operating conditions. Or, increase the motor capacity. | – |
| | An excessive load was applied during operation because the Servomotor was not driven because of mechanical problems. | Check the operation reference and motor speed. | Remove the mechanical problem. | – |
| | The overload warning level (Pn52B) is not suitable. | Check that the overload warning level (Pn52B) is suitable. | Set a suitable overload warning level (Pn52B). | * |
| | A failure occurred in the SERVOPACK. | – | The SERVOPACK may be faulty. Replace the SERVOPACK. | – |
| A.911: Vibration | Abnormal vibration was detected during motor operation. | Check for abnormal motor noise, and check the speed and torque waveforms during operation. | Reduce the motor speed. Or, reduce the servo gain with custom tuning. | * |
| | The setting of Pn103 (Moment of Inertia Ratio) is greater than the actual moment of inertia or was greatly changed. | Check the moment of inertia ratio or mass ratio. | Set Pn103 (Moment of Inertia Ratio) to an appropriate value. | * |
| | The vibration detection level (Pn312 or Pn384) is not suitable. | Check that the vibration detection level (Pn312 or Pn384) is suitable. | Set a suitable vibration detection level (Pn312 or Pn384). | * |

Continued on next page.

Continued from previous page.

| Warning Number: Warning Name | Possible Cause | Confirmation | Correction | Reference |
|--|--|---|--|-----------|
| A.912: Internal Temperature Warning 1 (Control Board Temperature Error) | The surrounding temperature is too high. | Check the surrounding temperature using a thermometer. Or, check the operating status with the SERVOPACK installation environment monitor. | Decrease the surrounding temperature by improving the SERVOPACK installation conditions. | * |
| | An overload alarm was reset by turning OFF the power supply too many times. | Check the alarm display to see if there is an overload alarm. | Change the method for resetting the alarm. | – |
| | There was an excessive load or operation was performed that exceeded the regenerative processing capacity. | Use the accumulated load ratio to check the load during operation, and use the regenerative load ratio to check the regenerative processing capacity. | Reconsider the load and operating conditions. | – |
| | The SERVOPACK installation orientation is not correct or there is insufficient space around the SERVOPACK. | Check the SERVOPACK installation conditions. | Install the SERVOPACK according to specifications. | * |
| | A failure occurred in the SERVOPACK. | – | The SERVOPACK may be faulty. Replace the SERVOPACK. | – |
| A.913: Internal Temperature Warning 2 (Power Board Temperature Error) | The surrounding temperature is too high. | Check the surrounding temperature using a thermometer. Or, check the operating status with the SERVOPACK installation environment monitor. | Decrease the surrounding temperature by improving the SERVOPACK installation conditions. | * |
| | An overload alarm was reset by turning OFF the power supply too many times. | Check the alarm display to see if there is an overload alarm. | Change the method for resetting the alarm. | – |
| | There was an excessive load or operation was performed that exceeded the regenerative processing capacity. | Use the accumulated load ratio to check the load during operation, and use the regenerative load ratio to check the regenerative processing capacity. | Reconsider the load and operating conditions. | – |
| | The SERVOPACK installation orientation is not correct or there is insufficient space around the SERVOPACK. | Check the SERVOPACK installation conditions. | Install the SERVOPACK according to specifications. | * |
| | A failure occurred in the SERVOPACK. | – | The SERVOPACK may be faulty. Replace the SERVOPACK. | – |

Continued on next page.

Continued from previous page.

| Warning Number: Warning Name | Possible Cause | Confirmation | Correction | Reference |
|--|---|--|---|-----------|
| A.920: Regenerative Overload (warning before an A.320 alarm occurs) | The power supply voltage exceeded the specified range. | Measure the power supply voltage. | Set the power supply voltage within the specified range. | – |
| | There is insufficient external regenerative resistance, regenerative resistor capacity, or SERVOPACK capacity, or there has been a continuous regeneration state. | Check the operating conditions or the capacity using the SigmaJunmaSize+ Capacity Selection Software or another means. | Change the regenerative resistance value, regenerative resistance capacity, or SERVOPACK capacity. Reconsider the operating conditions using the SigmaJunmaSize+ Capacity Selection Software or other means. | – |
| | There was a continuous regeneration state because a negative load was continuously applied. | Check the load applied to the Servomotor during operation. | Reconsider the system including the servo, machine, and operating conditions. | – |
| A.921: Dynamic Brake Overload (warning before an A.731 alarm occurs) | The Servomotor was rotated by an external force. | Check the operation status. | Implement measures to ensure that the motor will not be rotated by an external force. | – |
| | When the Servomotor was stopped with the dynamic brake, the rotational or linear kinetic energy exceeded the capacity of the dynamic brake resistor. | Check the power consumed by the DB resistor to see how frequently the DB is being used. | Reconsider the following: <ul style="list-style-type: none"> • Reduce the Servomotor command speed. • Decrease the moment of inertia or mass. • Reduce the frequency of stopping with the dynamic brake. | – |
| | A failure occurred in the SERVOPACK. | – | The SERVOPACK may be faulty. Replace the SERVOPACK. | – |
| A.923: SERVOPACK Built-in Fan Stopped | The fan inside the SERVOPACK stopped. | Check for foreign matter inside the SERVOPACK. | Remove foreign matter from the SERVOPACK. If an alarm still occurs, the SERVOPACK may be faulty. Replace the SERVOPACK. | – |
| A.930: Absolute Encoder Battery Error (The absolute encoder battery voltage was lower than the specified level.) (Detected only when an absolute encoder is connected.) | The battery connection is faulty or a battery is not connected. | Check the battery connection. | Correct the battery connection. | * |
| | The battery voltage is lower than the specified value (2.7 V). | Measure the battery voltage. | Replace the battery. | * |
| | A failure occurred in the SERVOPACK. | – | The SERVOPACK may be faulty. Replace the SERVOPACK. | – |

Continued on next page.

Continued from previous page.

| Warning Number: Warning Name | Possible Cause | Confirmation | Correction | Reference |
|--|--|--|---|-----------|
| A.93B: Overheat Warning | The surrounding temperature is too high. | Check the surrounding temperature using a thermometer. | Lower the surrounding temperature by improving the installation conditions of the Linear Servomotor or the machine. | - |
| | Operation was performed under an excessive load. | Use the accumulated load ratio to check the load during operation. | Reconsider the load and operating conditions. | - |
| | A failure occurred in the SERVOPACK. | - | The SERVOPACK may be faulty. Replace the SERVOPACK. | - |
| | The temperature detection circuit in the Linear Servomotor is faulty or the sensor attached to the machine is faulty. | - | The temperature detection circuit in the Linear Servomotor may be faulty or the sensor attached to the machine may be faulty. Replace the Linear Servomotor or repair the sensor attached to the machine. | - |
| A.942: Speed Ripple Compensation Information Disagreement | The speed ripple compensation information stored in the encoder does not agree with the speed ripple compensation information stored in the SERVOPACK. | - | Reset the speed ripple compensation value on the SigmaWin+. | * |
| | | - | Set Pn423 to n.□□1□ (Do not detect A.942 alarms). However, changing the setting may increase the speed ripple. | - |
| | | - | Set Pn423 to n.□□□0 (Disable speed ripple compensation). However, changing the setting may increase the speed ripple. | - |
| A.94A: Data Setting Warning 1 (Parameter Number Error) | An invalid parameter number was used. | Check the command that caused the warning. | Use the correct parameter number. | * |
| A.94b: Data Setting Warning 2 (Out of Range) | The set command data was clamped to the minimum or maximum value of the setting range. | Check the command that caused the warning. | Set the parameter within the setting range. | * |
| A.94C: Data Setting Warning 3 (Calculation Error) | The calculation result of the setting is not correct. | Check the command that caused the warning. | Set the parameter within the setting range. | * |
| A.94d: Data Setting Warning 4 (Parameter Size) | The parameter size set in the command is not correct. | Check the command that caused the warning. | Set the correct parameter size. | * |
| A.94E: Data Setting Warning 5 (Latch Mode Error) | A latch mode error was detected. | Check the command that caused the warning. | Change the setting of Pn850 or the LT_MOD data for the LTMOD_ON command sent by the host controller to an appropriate value. (This applies when using the MECHATROLINK-II-compatible profile.) | * |

Continued on next page.

Continued from previous page.

| Warning Number: Warning Name | Possible Cause | Confirmation | Correction | Reference |
|---|--|--|---|-----------|
| A.95A: Command Warning 1 (Unsatisfied Com- mand Conditions) | The command conditions are not satisfied. | Check the command that caused the warn- ing. | Send the command after the command conditions are satisfied. | * |
| A.95b: Command Warning 2 (Unsupported Command) | An unsupported command was received. | Check the command that caused the warn- ing. | Do not send unsupported commands. | * |
| A.95d: Command Warning 4 (Command Inter- ference) | The command sending condi- tions for latch- related com- mands was not satisfied. | Check the command that caused the warn- ing. | Send the command after the command conditions are satisfied. | * |
| A.95E: Command Warning 5 (Subcommand Not Possible) | The command sending condi- tions for subcom- mands was not satisfied. | Check the command that caused the warn- ing. | Send the command after the conditions are satisfied. | * |
| A.95F: Command Warning 6 (Undefined Com- mand) | An undefined command was sent. | Check the command that caused the warn- ing. | Do not send undefined commands. | * |
| A.960: MECHATROLINK Communications Warning | The MECHA- TROLINK Com- munications Cable is not wired cor- rectly. | Check the wiring con- ditions. | Correct the MECHA- TROLINK communications cable wiring. | * |
| | A MECHA- TROLINK data reception error occurred due to noise. | Confirm the installation conditions. | Implement the following countermeasures against noise. • Check the MECHA- TROLINK Communica- tions Cable and FG wiring and implement counter- measures to prevent noise from entering. • Attach a ferrite core to the MECHATROLINK Com- munications Cable. | – |
| | A failure occurred in the SERVO- PACK. | – | The SERVOPACK may be faulty. Replace the SERVO- PACK. | – |

Continued on next page.

Continued from previous page.

| Warning Number: Warning Name | Possible Cause | Confirmation | Correction | Reference |
|--|--|---|--|-----------|
| A.971: Undervoltage | For a 200-V SERVOPACK, the AC power supply voltage dropped below 140 V. | Measure the power supply voltage. | Set the power supply voltage within the specified range. | – |
| | For a 100-V SERVOPACK, the AC power supply voltage dropped below 60 V. | Measure the power supply voltage. | Set the power supply voltage within the specified range. | – |
| | The power supply voltage dropped during operation. | Measure the power supply voltage. | Increase the power supply capacity. | – |
| | A momentary power interruption occurred. | Measure the power supply voltage. | If you have changed the setting of Pn509 (Momentary Power Interruption Hold Time), decrease the setting. | * |
| | The SERVOPACK fuse is blown out. | – | Replace the SERVOPACK and connect a reactor. | * |
| | A failure occurred in the SERVOPACK. | – | The SERVOPACK may be faulty. Replace the SERVOPACK. | – |
| A.97A: Command Warning 7 (Phase Error) | A command that cannot be executed in the current phase was sent. | – | Send the command after the command conditions are satisfied. | – |
| A.97b: Data Clamp Out of Range | The set command data was clamped to the minimum or maximum value of the setting range. | – | Set the command data within the setting ranges. | – |
| A.9A0: Overtravel (Overtravel status was detected.) | Overtravel was detected while the servo was ON. | Check the status of the overtravel signals on the input signal monitor. | Even if an overtravel signal is not shown by the input signal monitor, momentary overtravel may have been detected. Take the following precautions. <ul style="list-style-type: none"> • Do not specify movements that would cause overtravel from the host controller. • Check the wiring of the overtravel signals. • Implement countermeasures against noise. | * |
| A.9b0: Preventative Maintenance Warning | One of the consumable parts has reached the end of its service life. | – | Replace the part. Contact your Yaskawa representative for replacement. | * |

* Refer to the following manual for details.

 Σ -7-Series Σ -7S SERVOPACK with MECHATROLINK-III Communications References Product Manual (Manual No.: SIEP S800001 28)

4.2.7 Troubleshooting Based on the Operation and Conditions of the Servomotor

This section provides troubleshooting based on the operation and conditions of the Servomotor, including causes and corrections.

| Problem | Possible Cause | Confirmation | Correction | Reference |
|---|---|---|---|-----------|
| Servomotor Does Not Start | The control power supply is not turned ON. | Measure the voltage between control power supply terminals. | Turn OFF the power supply to the servo system. Correct the wiring so that the control power supply is turned ON. | - |
| | The main circuit power supply is not turned ON. | Measure the voltage across the main circuit power input terminals. | Turn OFF the power supply to the servo system. Correct the wiring so that the main circuit power supply is turned ON. | - |
| | The I/O signal connector (CN1) pins are not wired correctly or are disconnected. | Turn OFF the power supply to the servo system. Check the wiring condition of the I/O signal connector (CN1) pins. | Correct the wiring of the I/O signal connector (CN1) pins. | * |
| | The wiring for the Servomotor Main Circuit Cables or Encoder Cable is disconnected. | Check the wiring conditions. | Turn OFF the power supply to the servo system. Wire the cable correctly. | - |
| | There is an overload on the Servomotor. | Operate the Servomotor with no load and check the load status. | Turn OFF the power supply to the servo system. Reduce the load or replace the Servomotor with a larger capacity. | - |
| | The type of encoder that is being used does not agree with the setting of Pn002 = n.□X□□ (Encoder Usage). | Check the type of the encoder that is being used and the setting of Pn002 = n.□X□□. | Set Pn002 = n.□X□□ according to the type of the encoder that is being used. | * |
| | There is a mistake in the input signal allocations (Pn50A, Pn50B, Pn511, and Pn516). | Check the input signal allocations (Pn50A, Pn50B, Pn511, and Pn516). | Correctly allocate the input signals (Pn50A, Pn50B, Pn511, and Pn516). | * |
| | The SV_ON command was not sent. | Check the commands sent from the host controller. | Send the SV_ON command from the host controller. | - |
| | The SENS_ON (Turn ON Sensor) command was not sent. | Check the commands sent from the host controller. | Send the commands to the SERVOPACK in the correct sequence. | - |
| | The P-OT (Forward Drive Prohibit) or N-OT (Reverse Drive Prohibit) signal is still OFF. | Check the P-OT and N-OT signals. | Turn ON the P-OT and N-OT signals. | * |
| The safety input signals (/HWBB1 or /HWBB2) were not turned ON. | Check the /HWBB1 and /HWBB2 input signals. | Turn ON the /HWBB1 and /HWBB2 input signals. If you are not using the safety function, connect the Safety Jumper Connector (provided as an accessory) to CN8. | * | |

Continued on next page.

Continued from previous page.

| Problem | Possible Cause | Confirmation | Correction | Reference |
|--|--|--|---|-----------|
| Servomotor Does Not Start | The FSTP (Forced Stop Input) signal is still OFF. | Check the FSTP signal. | <ul style="list-style-type: none"> Turn ON the FSTP signal. If you will not use the function to force the motor to stop, set Pn516 = n.□□□X (FSTP (Forced Stop Input) Signal Allocation) to disable the signal. | * |
| | A failure occurred in the SERVOPACK. | – | Turn OFF the power supply to the servo system. Replace the SERVOPACK. | – |
| | The polarity detection was not executed. | Check the setting of Pn080 = n.□□□X (Polarity Sensor Selection). | Correct the parameter setting. | * |
| | | Check the inputs to the SV_ON (Servo ON) command. | <ul style="list-style-type: none"> If you are using an incremental linear encoder, send the SV_ON command from the host controller. If you are using an absolute linear encoder, execute polarity detection. | * |
| Servomotor Moves Instantaneously, and Then Stops | There is a mistake in the Servomotor wiring. | Turn OFF the power supply to the servo system. Check the wiring. | Wire the Servomotor correctly. | – |
| | There is a mistake in the wiring of the encoder or Serial Converter Unit. | Turn OFF the power supply to the servo system. Check the wiring. | Wire the Serial Converter Unit correctly. | – |
| | There is a mistake in the linear encoder wiring. | Turn OFF the power supply to the servo system. Check the wiring. | Wire the cable correctly. | – |
| | The setting of Pn282 (Linear Encoder Scale Pitch) is not correct. | Check the setting of Pn282. | Correct the setting of Pn282. | * |
| | The count-up direction of the linear encoder does not match the forward direction of the Moving Coil in the motor. | Check the directions. | Change the setting of Pn080 = n.□□X□ (Motor Phase Sequence Selection). Place the linear encoder and motor in the same direction. | * |
| | Polarity detection was not performed correctly. | Check to see if electrical angle 2 (electrical angle from polarity origin) at any position is between $\pm 10^\circ$. | Correct the settings for the polarity detection-related parameters. | – |
| Servomotor Speed Is Unstable | There is a faulty connection in the Servomotor wiring. | The connector connections for the power line (U, V, and W phases) and the encoder or Serial Converter Unit may be unstable. Turn OFF the power supply to the servo system. Check the wiring. | Tighten any loose terminals or connectors and correct the wiring. | – |

Continued on next page.

Continued from previous page.

| Problem | Possible Cause | Confirmation | Correction | Reference |
|--|--|--|---|-----------|
| Servomotor Moves without a Reference Input | A failure occurred in the SERVOPACK. | - | Turn OFF the power supply to the servo system. Replace the SERVOPACK. | - |
| | The count-up direction of the linear encoder does not match the forward direction of the Moving Coil in the motor. | Check the directions. | Change the setting of Pn080 = n.□□X□ (Motor Phase Sequence Selection). Match the linear encoder direction and Servomotor direction. | * |
| | Polarity detection was not performed correctly. | Check to see if electrical angle 2 (electrical angle from polarity origin) at any position is between $\pm 10^\circ$. | Correct the settings for the polarity detection-related parameters. | - |
| Dynamic Brake Does Not Operate | The setting of Pn001 = n.□□□X (Motor Stopping Method for Servo OFF and Group 1 Alarms) is not suitable. | Check the setting of Pn001 = n.□□□X. | Set Pn001 = n.□□□X correctly. | - |
| | The dynamic brake resistor is disconnected. | Check the moment of inertia, motor speed, and dynamic brake frequency of use. If the moment of inertia, motor speed, or dynamic brake frequency of use is excessive, the dynamic brake resistance may be disconnected. | Turn OFF the power supply to the servo system. Replace the SERVOPACK. To prevent disconnection, reduce the load. | - |
| | There was a failure in the dynamic brake drive circuit. | - | There is a defective component in the dynamic brake circuit. Turn OFF the power supply to the servo system. Replace the SERVOPACK. | - |
| Abnormal Noise from Servomotor | The Servomotor vibrated considerably while performing the tuning-less function with the default settings. | Check the waveform of the motor speed. | Reduce the load so that the moment of inertia ratio or mass ratio is within the allowable value, or increase the load level or reduce the rigidity level in the tuning-less level settings. If the situation is not improved, disable the tuning-less function (i.e., set Pn170 to n.□□□0) and execute autotuning either with or without a host reference. | * |

Continued on next page.

Continued from previous page.

| Problem | Possible Cause | Confirmation | Correction | Reference |
|--|---|--|---|-----------|
| Abnormal Noise from Servomotor | The machine mounting is not secure. | Turn OFF the power supply to the servo system. Check to see if there are any loose mounting screws. | Tighten the mounting screws. | - |
| | | Turn OFF the power supply to the servo system. Check to see if there is misalignment in the coupling. | Align the coupling. | - |
| | | Turn OFF the power supply to the servo system. Check to see if the coupling is balanced. | Balance the coupling. | - |
| | The bearings are defective. | Turn OFF the power supply to the servo system. Check for noise and vibration around the bearings. | Replace the Servomotor. | - |
| | There is a vibration source at the driven machine. | Turn OFF the power supply to the servo system. Check for any foreign matter, damage, or deformation in the machine's moving parts. | Consult with the machine manufacturer. | - |
| | Noise interference occurred because of incorrect I/O signal cable specifications. | Turn OFF the power supply to the servo system. Check the I/O signal cables to see if they satisfy specifications. Use shielded twisted-pair wire cables or screened twisted-pair cables with conductors of at least 0.12 mm ² . | Use cables that satisfy the specifications. | - |
| | Noise interference occurred because an I/O signal cable is too long. | Turn OFF the power supply to the servo system. Check the lengths of the I/O signal cables. | The I/O signal cables must be no longer than 3 m. | - |
| Noise interference occurred because of incorrect Encoder Cable specifications. | Turn OFF the power supply to the servo system. Make sure that the rotary or Linear Encoder Cable satisfies the specifications. Use a shielded twisted-pair wire cable or a screened twisted-pair cable with a conductors of at least 0.12 mm ² . | Use cables that satisfy the specifications. | - | |

Continued on next page.

Continued from previous page.

| Problem | Possible Cause | Confirmation | Correction | Reference |
|--------------------------------|---|--|--|-----------|
| Abnormal Noise from Servomotor | Noise interference occurred because the Encoder Cable is too long. | Turn OFF the power supply to the servo system. Check the length of the Encoder Cable. | <ul style="list-style-type: none"> Rotary Servomotors: The Encoder Cable length must be 50 m max. Linear Servomotors: Make sure that the Serial Converter Unit cable is no longer than 20 m and that the Linear Encoder Cable and the Sensor Cable are no longer than 15 m each. | - |
| | Noise interference occurred because the Encoder Cable is damaged. | Turn OFF the power supply to the servo system. Check the Encoder Cable to see if it is pinched or the sheath is damaged. | Replace the Encoder Cable and correct the cable installation environment. | - |
| | The Encoder Cable was subjected to excessive noise interference. | Turn OFF the power supply to the servo system. Check to see if the Encoder Cable is bundled with a high-current line or installed near a high-current line. | Correct the cable layout so that no surge is applied by high-current lines. | - |
| | There is variation in the FG potential because of the influence of machines on the Servomotor side, such as a welder. | Turn OFF the power supply to the servo system. Check to see if the machines are correctly grounded. | Properly ground the machines to separate them from the FG of the encoder. | - |
| | There is a SERVOPACK pulse counting error due to noise. | Check to see if there is noise interference on the signal line from the encoder. | Turn OFF the power supply to the servo system. Implement countermeasures against noise for the encoder wiring. | - |
| | The encoder was subjected to excessive vibration or shock. | Turn OFF the power supply to the servo system. Check to see if vibration from the machine occurred. Check the Servomotor installation (mounting surface precision, securing state, and alignment). Check the linear encoder installation (mounting surface precision and securing method). | Reduce machine vibration. Improve the mounting state of the Servomotor or linear encoder. | - |
| | A failure occurred in the encoder. | - | Turn OFF the power supply to the servo system. Replace the Servomotor. | - |
| | A failure occurred in the Serial Converter Unit. | - | Turn OFF the power supply to the servo system. Replace the Serial Converter Unit. | - |
| | A failure occurred in the linear encoder. | - | Turn OFF the power supply to the servo system. Replace the linear encoder. | - |

Continued on next page.

Continued from previous page.

| Problem | Possible Cause | Confirmation | Correction | Reference |
|--|--|---|--|-----------|
| Servomotor Vibrates at Frequency of Approx. 200 to 400 Hz. | The servo gains are not balanced. | Check to see if the servo gains have been correctly tuned. | Perform autotuning without a host reference. | * |
| | The setting of Pn100 (Speed Loop Gain) is too high. | Check the setting of Pn100. The default setting is Kv = 40.0 Hz. | Set Pn100 to an appropriate value. | - |
| | The setting of Pn102 (Position Loop Gain) is too high. | Check the setting of Pn102. The default setting is Kp = 40.0/s. | Set Pn102 to an appropriate value. | - |
| | The setting of Pn101 (Speed Loop Integral Time Constant) is not appropriate. | Check the setting of Pn101. The default setting is Ti = 20.0 ms. | Set Pn101 to an appropriate value. | - |
| | The setting of Pn103 (Moment of Inertia Ratio or Mass Ratio) is not appropriate. | Check the setting of Pn103. | Set Pn103 to an appropriate value. | - |
| Large Motor Speed Overshoot on Starting and Stopping | The servo gains are not balanced. | Check to see if the servo gains have been correctly tuned. | Perform autotuning without a host reference. | * |
| | The setting of Pn100 (Speed Loop Gain) is too high. | Check the setting of Pn100. The default setting is Kv = 40.0 Hz. | Set Pn100 to an appropriate value. | - |
| | The setting of Pn102 (Position Loop Gain) is too high. | Check the setting of Pn102. The default setting is Kp = 40.0/s. | Set Pn102 to an appropriate value. | - |
| | The setting of Pn101 (Speed Loop Integral Time Constant) is not appropriate. | Check the setting of Pn101. The default setting is Ti = 20.0 ms. | Set Pn101 to an appropriate value. | - |
| | The setting of Pn103 (Moment of Inertia Ratio or Mass Ratio) is not appropriate. | Check the setting of Pn103. | Set Pn103 to an appropriate value. | - |
| | The torque reference is saturated. | Check the waveform of the torque reference. | Use the mode switch. | - |
| | The force limits (Pn483 and Pn484) are set to the default values. | The default values of the force limits and Pn483 = 30% and Pn484 = 30%. | Set Pn483 and Pn484 to appropriate values. | * |

Continued on next page.

Continued from previous page.

| Problem | Possible Cause | Confirmation | Correction | Reference |
|--|---|--|--|-----------|
| Absolute Encoder Position Deviation Error (The position that was saved in the host controller when the power was turned OFF is different from the position when the power was next turned ON.) | Noise interference occurred because of incorrect Encoder Cable specifications. | Turn OFF the power supply to the servo system. Check the Encoder Cable to see if it satisfies specifications. Use a shielded twisted-pair wire cable or a screened twisted-pair cable with conductors of at least 0.12 mm ² . | Use cables that satisfy the specifications. | - |
| | Noise interference occurred because the Encoder Cable is too long. | Turn OFF the power supply to the servo system. Check the length of the Encoder Cable. | <ul style="list-style-type: none"> Rotary Servomotors: The Encoder Cable length must be 50 m max. Linear Servomotors: Make sure that the Serial Converter Unit cable is no longer than 20 m and that the Linear Encoder Cable and the Sensor Cable are no longer than 15 m each. | - |
| | Noise interference occurred because the Encoder Cable is damaged. | Turn OFF the power supply to the servo system. Check the Encoder Cable to see if it is pinched or the sheath is damaged. | Replace the Encoder Cable and correct the cable installation environment. | - |
| | Replace the Encoder Cable and correct the cable installation environment. | Turn OFF the power supply to the servo system. Check to see if the Encoder Cable is bundled with a high-current line or installed near a high-current line. | Correct the cable layout so that no surge is applied by high-current lines. | - |
| | There is variation in the FG potential because of the influence of machines on the Servomotor side, such as a welder. | Turn OFF the power supply to the servo system. Check to see if the machines are correctly grounded. | Properly ground the machines to separate them from the FG of the encoder. | - |
| | There is a SERVOPACK pulse counting error due to noise. | Turn OFF the power supply to the servo system. Check to see if there is noise interference on the I/O signal line from the encoder or Serial Converter Unit. | Implement countermeasures against noise for the encoder or Serial Converter Unit wiring. | - |
| | The encoder was subjected to excessive vibration or shock. | Turn OFF the power supply to the servo system. Check to see if vibration from the machine occurred. Check the Servomotor installation (mounting surface precision, securing state, and alignment). Check the linear encoder installation (mounting surface precision and securing method). | Reduce machine vibration. Improve the mounting state of the Servomotor or linear encoder. | - |
| | A failure occurred in the encoder. | - | Turn OFF the power supply to the servo system. Replace the Servomotor or linear encoder. | - |

Continued on next page.

Continued from previous page.

| Problem | Possible Cause | Confirmation | Correction | Reference |
|--|---|---|--|-----------|
| Absolute Encoder Position Deviation Error (The position that was saved in the host controller when the power was turned OFF is different from the position when the power was next turned ON.) | A failure occurred in the SERVOPACK. | – | Turn OFF the power supply to the servo system. Replace the SERVOPACK. | – |
| | Host Controller Multiturn Data or Absolute Encoder Position Data Reading Error | Check the error detection section of the host controller. | Correct the error detection section of the host controller. | – |
| | | Check to see if the host controller is executing data parity checks. | Perform parity checks for the multiturn data or absolute encoder position data. | – |
| | | Check for noise interference in the cable between the SERVOPACK and the host controller. | Implement countermeasures against noise and then perform parity checks again for the multiturn data or absolute encoder position data. | – |
| Overtravel Occurred | The P-OT/N-OT (Forward Drive Prohibit or Reverse Drive Prohibit) signal was input. | Check the external power supply (+24 V) voltage for the input signals. | Correct the external power supply (+24 V) voltage for the input signals. | – |
| | | Check the operating condition of the overtravel limit switches. | Make sure that the overtravel limit switches operate correctly. | – |
| | | Check the wiring of the overtravel limit switches. | Correct the wiring of the overtravel limit switches. | * |
| | | Check the settings of the overtravel input signal allocations (Pn50A/ Pn50B). | Set the parameters to correct values. | * |
| | The P-OT/N-OT (Forward Drive Prohibit or Reverse Drive Prohibit) signal malfunctioned. | Check for fluctuation in the external power supply (+24 V) voltage for the input signals. | Eliminate fluctuation from the external power supply (+24 V) voltage for the input signals. | – |
| | | Check to see if the operation of the overtravel limit switches is unstable. | Stabilize the operating condition of the overtravel limit switches. | – |
| Check the wiring of the overtravel limit switches (e.g., check for cable damage and loose screws). | | Correct the wiring of the overtravel limit switches. | – | |
| Overtravel Occurred | There is a mistake in the allocation of the P-OT or N-OT (Forward Drive Prohibit or Reverse Drive Prohibit) signal in Pn50A = n.X□□□ or Pn50B = n.□□□X. | Check to see if the P-OT signal is allocated in Pn50A = n.X□□□. | If another signal is allocated in Pn50A = n.X□□□, allocate the P-OT signal instead. | * |
| | | Check to see if the N-OT signal is allocated in Pn50B = n.□□□X. | If another signal is allocated in Pn50B = n.□□□X, allocate the N-OT signal instead. | * |
| | The selection of the Servomotor stopping method is not correct. | Check the servo OFF stopping method set in Pn001 = n.□□□X or Pn001 = n.□□X□. | Select a Servomotor stopping method other than coasting to a stop. | * |
| | | Check the torque control stopping method set in Pn001 = n.□□□X or Pn001 = n.□□X□. | Select a Servomotor stopping method other than coasting to a stop. | * |

Continued on next page.

Continued from previous page.

| Problem | Possible Cause | Confirmation | Correction | Reference |
|---|---|---|--|-----------|
| Improper Stop Position for Overtravel (OT) Signal | The limit switch position and dog length are not appropriate. | - | Install the limit switch at the appropriate position. | - |
| | The overtravel limit switch position is too close for the coasting distance. | - | Install the overtravel limit switch at the appropriate position. | - |
| Position Deviation (without Alarm) | Noise interference occurred because of incorrect Encoder Cable specifications. | Turn OFF the power supply to the servo system. Check the Encoder Cable to see if it satisfies specifications. Use a shielded twisted-pair wire cable or a screened twisted-pair cable with conductors of at least 0.12 mm ² . | Use cables that satisfy the specifications. | - |
| | Noise interference occurred because the Encoder Cable is too long. | Turn OFF the power supply to the servo system. Check the length of the Encoder Cable. | <ul style="list-style-type: none"> Rotary Servomotors: The Encoder Cable length must be 50 m max. Linear Servomotors: Make sure that the Serial Converter Unit cable is no longer than 20 m and that the Linear Encoder Cable and the Sensor Cable are no longer than 15 m each. | - |
| | Noise interference occurred because the Encoder Cable is damaged. | Turn OFF the power supply to the servo system. Check the Encoder Cable to see if it is pinched or the sheath is damaged. | Replace the Encoder Cable and correct the cable installation environment. | - |
| | The Encoder Cable was subjected to excessive noise interference. | Turn OFF the power supply to the servo system. Check to see if the Encoder Cable is bundled with a high-current line or installed near a high-current line. | Correct the cable layout so that no surge is applied by high-current lines. | - |
| | There is variation in the FG potential because of the influence of machines on the Servomotor side, such as a welder. | Turn OFF the power supply to the servo system. Check to see if the machines are correctly grounded. | Properly ground the machines to separate them from the FG of the encoder. | - |
| | There is a SERVOPACK pulse counting error due to noise. | Turn OFF the power supply to the servo system. Check to see if there is noise interference on the I/O signal line from the encoder or Serial Converter Unit. | Implement countermeasures against noise for the encoder wiring or Serial Converter Unit wiring. | - |

Continued on next page.

Continued from previous page.

| Problem | Possible Cause | Confirmation | Correction | Reference |
|------------------------------------|---|---|---|-----------|
| Position Deviation (without Alarm) | The encoder was subjected to excessive vibration or shock. | Turn OFF the power supply to the servo system. Check to see if vibration from the machine occurred. Check the Servomotor installation (mounting surface precision, securing state, and alignment). Check the linear encoder installation (mounting surface precision and securing method). | Reduce machine vibration. Improve the mounting state of the Servomotor or linear encoder. | - |
| | The coupling between the machine and Servomotor is not suitable. | Turn OFF the power supply to the servo system. Check to see if position offset occurs at the coupling between machine and Servomotor. | Correctly secure the coupling between the machine and Servomotor. | - |
| | Noise interference occurred because of incorrect I/O signal cable specifications. | Turn OFF the power supply to the servo system. Check the I/O signal cables to see if they satisfy specifications. Use a shielded twisted-pair wire cable or a screened twisted-pair cable with conductors of at least 0.12 mm ² . | Use cables that satisfy the specifications. | - |
| Position Deviation (without Alarm) | Noise interference occurred because an I/O signal cable is too long. | Turn OFF the power supply to the servo system. Check the lengths of the I/O signal cables. | The I/O signal cables must be no longer than 3 m. | - |
| | An encoder fault occurred. (The pulse count does not change.) | - | Turn OFF the power supply to the servo system. Replace the Servomotor or linear encoder. | - |
| | A failure occurred in the SERVOPACK. | - | Turn OFF the power supply to the servo system. Replace the SERVOPACK. | - |
| Servomotor Overheated | The surrounding air temperature is too high. | Measure the surrounding air temperature around the Servomotor. | Reduce the surrounding air temperature to 40°C or less. | - |
| | The surface of the Servomotor is dirty. | Turn OFF the power supply to the servo system. Visually check the surface for dirt. | Clean dirt, dust, and oil from the surface. | - |
| | There is an overload on the Servomotor. | Check the load status with a monitor. | If the Servomotor is overloaded, reduce the load or replace the Servo Drive with a SERVOPACK and Servomotor with larger capacities. | - |
| | Polarity detection was not performed correctly. | Check to see if electrical angle 2 (electrical angle from polarity origin) at any position is between ±10°. | Correct the settings for the polarity detection-related parameters. | - |

* Refer to the following manual for details.

 Σ-7-Series Σ-7S SERVOPACK with MECHATROLINK-III Communications References Product Manual (Manual No.: SIEP S800001 28)

Parameter Lists



This chapter provides information on the parameters.

5.1 SERVOPACKs with Analog Voltage/Pulse Train References . . . 5-2

- 5.1.1 Interpreting the Parameter Lists 5-2
- 5.1.2 List of Parameters 5-3
- 5.1.3 Parameter Recording Table 5-36

5.2 SERVOPACKs with MECHATROLINK-III Communications References . . 5-44

- 5.2.1 Interpreting the Parameter Lists 5-44
- 5.2.2 List of Servo Parameters 5-45
- 5.2.3 List of MECHATROLINK-III Common
Parameters 5-85
- 5.2.4 Parameter Recording Table 5-93

5.1 SERVOPACKs with Analog Voltage/Pulse Train References

5.1.1 Interpreting the Parameter Lists

The types of motors to which the parameter applies.

- All: The parameter is used for both Rotary Servomotors and Linear Servomotors.
- Rotary: The parameter is used for only Rotary Servomotors.
- Linear: The parameter is used for only Linear Servomotors.

Rotary Servomotor terms are used for parameters that are applicable to all Servomotors. If you are using a Linear Servomotor, you need to interpret the terms accordingly. Refer to the following section for details.

◆ Differences in Terms for Rotary Servomotors and Linear Servomotors on page xii

Indicates when a change to the parameter will be effective.

| Parameter No. | Size | Name | Setting Range | Setting Unit | Default Setting | Applicable Motors | When Enabled | Classification | Reference |
|---------------|---|---|---|--------------|-----------------|-------------------|---------------|----------------|-----------|
| Pn000 | 2 | Basic Function Selections 0 | 0000h to 10B1h | - | 0000h | All | After restart | Setup | - |
| | n.□□□X | Rotation Direction Selection | | Reference | | | | | |
| | | Movement Direction Selection | | Reference | | | | | |
| | | 0 | Use CCW as the forward direction. | - | | | | | |
| | | | Use the direction in which the linear encoder counts up as the forward direction. | | | | | | |
| | 1 | Use CW as the forward direction. (Reverse Rotation Mode) | - | | | | | | |
| | | Use the direction in which the linear encoder counts down as the forward direction. (Reverse Movement Mode) | | | | | | | |
| | n.□□X□ | Control Method Selection | | Reference | | | | | |
| | | 0 | Speed control with analog references | - | | | | | |
| | | 1 | Position control with pulse train references | | | | | | |
| 2 | | Torque control with analog references | | | | | | | |
| 3 | | Internal set speed control with contact commands | | | | | | | |
| 4 | | Switching between internal set speed control with contact references and speed control with analog references | | | | | | | |
| 5 | | Switching between internal set speed control with contact references and position control with pulse train references | | | | | | | |
| 6 | | Switching between internal set speed control with contact references and torque control with analog references | | | | | | | |
| 7 | | Switching between position control with pulse train references and speed control with analog references | | | | | | | |
| 8 | | Switching between position control with pulse train references and torque control with analog references | | | | | | | |
| 9 | | Switching between torque control with analog references and speed control with analog references | | | | | | | |
| A | Switching between speed control with analog references and speed control with zero clamping | | | | | | | | |
| B | Switching between position control with pulse train references and position control with reference pulse inhibition | | | | | | | | |
| n.□X□□ | Reserved parameter (Do not change.) | | | | | | | | |
| n.X□□□ | Rotary/Linear Servomotor Startup Selection When Encoder Is Not Connected | | Reference | | | | | | |
| | 0 | When an encoder is not connected, start as SERVOPACK for Rotary Servomotor. | - | | | | | | |
| 1 | When an encoder is not connected, start as SERVOPACK for Linear Servomotor. | | | | | | | | |

If there are differences in the parameters for Rotary Servomotor and Linear Servomotor, information is provided for both.

- Top row: For Rotary Servomotors
- Bottom row: For Linear Servomotors

There are the following two classifications.

- Setup
- Tuning

Refer to the following manual for details.

Σ-7-Series Σ-7S SERVOPACK with Analog Voltage/Pulse Train References Product Manual (Manual No.: SIEP S800001 26)

5.1.2 List of Parameters

The following table lists the parameters.

Note: Do not change the following parameters from their default settings.

- Reserved parameters
- Parameters not given in this manual
- Parameters that are not valid for the Servomotor that you are using, as given in the parameter table

| Parameter No. | Size | Name | Setting Range | Setting Unit | Default Setting | Applicable Motors | When Enabled | Classification | Reference | | | | | | | | | | | | | | | | | | | | | | | | | | | |
|---------------|--|---|--|--------------|-----------------|-------------------|---------------|----------------|-----------|--|--|--|------------------------------|---|---|--|---|---|---|--|---|---|---|---|---|--|---|---|---|--|---|--|---|---|---|---|
| Pn000 | 2 | Basic Function Selections 0 | 0000h to 10B1h | – | 0000h | All | After restart | Setup | *1 | | | | | | | | | | | | | | | | | | | | | | | | | | | |
| | n.□□□X | | <table border="1"> <thead> <tr> <th colspan="2">Rotation Direction Selection</th> </tr> <tr> <th colspan="2">Movement Direction Selection</th> </tr> </thead> <tbody> <tr> <td>0</td> <td>Use CCW as the forward direction. Use the direction in which the linear encoder counts up as the forward direction.</td> </tr> <tr> <td>1</td> <td>Use CW as the forward direction. (Reverse Rotation Mode) Use the direction in which the linear encoder counts down as the forward direction. (Reverse Movement Mode)</td> </tr> </tbody> </table> | | | | | | | | Rotation Direction Selection | | Movement Direction Selection | | 0 | Use CCW as the forward direction. Use the direction in which the linear encoder counts up as the forward direction. | 1 | Use CW as the forward direction. (Reverse Rotation Mode) Use the direction in which the linear encoder counts down as the forward direction. (Reverse Movement Mode) | | | | | | | | | | | | | | | | | | |
| | Rotation Direction Selection | | | | | | | | | | | | | | | | | | | | | | | | | | | | | | | | | | | |
| | Movement Direction Selection | | | | | | | | | | | | | | | | | | | | | | | | | | | | | | | | | | | |
| | 0 | Use CCW as the forward direction. Use the direction in which the linear encoder counts up as the forward direction. | | | | | | | | | | | | | | | | | | | | | | | | | | | | | | | | | | |
| | 1 | Use CW as the forward direction. (Reverse Rotation Mode) Use the direction in which the linear encoder counts down as the forward direction. (Reverse Movement Mode) | | | | | | | | | | | | | | | | | | | | | | | | | | | | | | | | | | |
| | n.□□X□ | | <table border="1"> <thead> <tr> <th colspan="2">Control Method Selection</th> </tr> </thead> <tbody> <tr> <td>0</td> <td>Speed control with analog references</td> </tr> <tr> <td>1</td> <td>Position control with pulse train references</td> </tr> <tr> <td>2</td> <td>Torque control with analog references</td> </tr> <tr> <td>3</td> <td>Internal set speed control with contact commands</td> </tr> <tr> <td>4</td> <td>Switching between internal set speed control with contact references and speed control with analog references</td> </tr> <tr> <td>5</td> <td>Switching between internal set speed control with contact references and position control with pulse train references</td> </tr> <tr> <td>6</td> <td>Switching between internal set speed control with contact references and torque control with analog references</td> </tr> <tr> <td>7</td> <td>Switching between position control with pulse train references and speed control with analog references</td> </tr> <tr> <td>8</td> <td>Switching between position control with pulse train references and torque control with analog references</td> </tr> <tr> <td>9</td> <td>Switching between torque control with analog references and speed control with analog references</td> </tr> <tr> <td>A</td> <td>Switching between speed control with analog references and speed control with zero clamping</td> </tr> <tr> <td>B</td> <td>Switching between position control with pulse train references and position control with reference pulse inhibition</td> </tr> </tbody> </table> | | | | | | | | Control Method Selection | | 0 | Speed control with analog references | 1 | Position control with pulse train references | 2 | Torque control with analog references | 3 | Internal set speed control with contact commands | 4 | Switching between internal set speed control with contact references and speed control with analog references | 5 | Switching between internal set speed control with contact references and position control with pulse train references | 6 | Switching between internal set speed control with contact references and torque control with analog references | 7 | Switching between position control with pulse train references and speed control with analog references | 8 | Switching between position control with pulse train references and torque control with analog references | 9 | Switching between torque control with analog references and speed control with analog references | A | Switching between speed control with analog references and speed control with zero clamping | B | Switching between position control with pulse train references and position control with reference pulse inhibition |
| | Control Method Selection | | | | | | | | | | | | | | | | | | | | | | | | | | | | | | | | | | | |
| | 0 | Speed control with analog references | | | | | | | | | | | | | | | | | | | | | | | | | | | | | | | | | | |
| | 1 | Position control with pulse train references | | | | | | | | | | | | | | | | | | | | | | | | | | | | | | | | | | |
| | 2 | Torque control with analog references | | | | | | | | | | | | | | | | | | | | | | | | | | | | | | | | | | |
| | 3 | Internal set speed control with contact commands | | | | | | | | | | | | | | | | | | | | | | | | | | | | | | | | | | |
| | 4 | Switching between internal set speed control with contact references and speed control with analog references | | | | | | | | | | | | | | | | | | | | | | | | | | | | | | | | | | |
| | 5 | Switching between internal set speed control with contact references and position control with pulse train references | | | | | | | | | | | | | | | | | | | | | | | | | | | | | | | | | | |
| | 6 | Switching between internal set speed control with contact references and torque control with analog references | | | | | | | | | | | | | | | | | | | | | | | | | | | | | | | | | | |
| | 7 | Switching between position control with pulse train references and speed control with analog references | | | | | | | | | | | | | | | | | | | | | | | | | | | | | | | | | | |
| | 8 | Switching between position control with pulse train references and torque control with analog references | | | | | | | | | | | | | | | | | | | | | | | | | | | | | | | | | | |
| | 9 | Switching between torque control with analog references and speed control with analog references | | | | | | | | | | | | | | | | | | | | | | | | | | | | | | | | | | |
| | A | Switching between speed control with analog references and speed control with zero clamping | | | | | | | | | | | | | | | | | | | | | | | | | | | | | | | | | | |
| | B | Switching between position control with pulse train references and position control with reference pulse inhibition | | | | | | | | | | | | | | | | | | | | | | | | | | | | | | | | | | |
| | n.□X□□ | | Reserved parameter (Do not change.) | | | | | | | | | | | | | | | | | | | | | | | | | | | | | | | | | |
| | n.X□□□ | | <table border="1"> <thead> <tr> <th colspan="2">Rotary/Linear Servomotor Startup Selection When Encoder Is Not Connected</th> </tr> </thead> <tbody> <tr> <td>0</td> <td>When an encoder is not connected, start as SERVOPACK for Rotary Servomotor.</td> </tr> <tr> <td>1</td> <td>When an encoder is not connected, start as SERVOPACK for Linear Servomotor.</td> </tr> </tbody> </table> | | | | | | | | Rotary/Linear Servomotor Startup Selection When Encoder Is Not Connected | | 0 | When an encoder is not connected, start as SERVOPACK for Rotary Servomotor. | 1 | When an encoder is not connected, start as SERVOPACK for Linear Servomotor. | | | | | | | | | | | | | | | | | | | | |
| | Rotary/Linear Servomotor Startup Selection When Encoder Is Not Connected | | | | | | | | | | | | | | | | | | | | | | | | | | | | | | | | | | | |
| | 0 | When an encoder is not connected, start as SERVOPACK for Rotary Servomotor. | | | | | | | | | | | | | | | | | | | | | | | | | | | | | | | | | | |
| | 1 | When an encoder is not connected, start as SERVOPACK for Linear Servomotor. | | | | | | | | | | | | | | | | | | | | | | | | | | | | | | | | | | |

Continued on next page.

5.1 SERVOPACKs with Analog Voltage/Pulse Train References

5.1.2 List of Parameters

Continued from previous page.

| Parameter No. | Size | Name | Setting Range | Setting Unit | Default Setting | Applicable Motors | When Enabled | Classification | Reference | | | | | | | | | | | | | |
|---------------|---|--|---|--------------|-----------------|-------------------|---------------|----------------|-----------|--|--|--------|---|---|---|--|---|--|---|--|---|---|
| Pn001 | 2 | Application Function Selections 1 | 0000h to 1142h | - | 0000h | All | After restart | Setup | *1 | | | | | | | | | | | | | |
| | <table border="1"> <thead> <tr> <th colspan="2">Motor Stopping Method for Servo OFF and Group 1 Alarms</th> </tr> </thead> <tbody> <tr> <td rowspan="3">n.□□□X</td> <td>0</td> <td>Stop the motor by applying the dynamic brake.</td> </tr> <tr> <td>1</td> <td>Stop the motor by the applying dynamic brake and then release the dynamic brake.</td> </tr> <tr> <td>2</td> <td>Coast the motor to a stop without the dynamic brake.</td> </tr> </tbody> </table> | | | | | | | | | Motor Stopping Method for Servo OFF and Group 1 Alarms | | n.□□□X | 0 | Stop the motor by applying the dynamic brake. | 1 | Stop the motor by the applying dynamic brake and then release the dynamic brake. | 2 | Coast the motor to a stop without the dynamic brake. | | | | |
| | Motor Stopping Method for Servo OFF and Group 1 Alarms | | | | | | | | | | | | | | | | | | | | | |
| | n.□□□X | 0 | Stop the motor by applying the dynamic brake. | | | | | | | | | | | | | | | | | | | |
| | | 1 | Stop the motor by the applying dynamic brake and then release the dynamic brake. | | | | | | | | | | | | | | | | | | | |
| | | 2 | Coast the motor to a stop without the dynamic brake. | | | | | | | | | | | | | | | | | | | |
| | <table border="1"> <thead> <tr> <th colspan="2">Overtravel Stopping Method</th> </tr> </thead> <tbody> <tr> <td rowspan="5">n.□□X□</td> <td>0</td> <td>Apply the dynamic brake or coast the motor to a stop (use the stopping method set in Pn001 = n.□□□X).</td> </tr> <tr> <td>1</td> <td>Decelerate the motor to a stop using the torque set in Pn406 as the maximum torque and then servo-lock the motor.</td> </tr> <tr> <td>2</td> <td>Decelerate the motor to a stop using the torque set in Pn406 as the maximum torque and then let the motor coast.</td> </tr> <tr> <td>3</td> <td>Decelerate the motor to a stop using the deceleration time set in Pn30A and then servo-lock the motor.</td> </tr> <tr> <td>4</td> <td>Decelerate the motor to a stop using the deceleration time set in Pn30A and then let the motor coast.</td> </tr> </tbody> </table> | | | | | | | | | Overtravel Stopping Method | | n.□□X□ | 0 | Apply the dynamic brake or coast the motor to a stop (use the stopping method set in Pn001 = n.□□□X). | 1 | Decelerate the motor to a stop using the torque set in Pn406 as the maximum torque and then servo-lock the motor. | 2 | Decelerate the motor to a stop using the torque set in Pn406 as the maximum torque and then let the motor coast. | 3 | Decelerate the motor to a stop using the deceleration time set in Pn30A and then servo-lock the motor. | 4 | Decelerate the motor to a stop using the deceleration time set in Pn30A and then let the motor coast. |
| | Overtravel Stopping Method | | | | | | | | | | | | | | | | | | | | | |
| | n.□□X□ | 0 | Apply the dynamic brake or coast the motor to a stop (use the stopping method set in Pn001 = n.□□□X). | | | | | | | | | | | | | | | | | | | |
| | | 1 | Decelerate the motor to a stop using the torque set in Pn406 as the maximum torque and then servo-lock the motor. | | | | | | | | | | | | | | | | | | | |
| | | 2 | Decelerate the motor to a stop using the torque set in Pn406 as the maximum torque and then let the motor coast. | | | | | | | | | | | | | | | | | | | |
| | | 3 | Decelerate the motor to a stop using the deceleration time set in Pn30A and then servo-lock the motor. | | | | | | | | | | | | | | | | | | | |
| | | 4 | Decelerate the motor to a stop using the deceleration time set in Pn30A and then let the motor coast. | | | | | | | | | | | | | | | | | | | |
| | <table border="1"> <thead> <tr> <th colspan="2">Main Circuit Power Supply AC/DC Input Selection</th> </tr> </thead> <tbody> <tr> <td rowspan="2">n.□X□□</td> <td>0</td> <td>Input AC power as the main circuit power supply using the L1, L2, and L3 terminals (do not use shared converter).</td> </tr> <tr> <td>1</td> <td>Input DC power as the main circuit power supply using the B1/⊕ and ⊖ 2 terminals or the B1 and ⊖ 2 terminals (use an external converter or the shared converter).</td> </tr> </tbody> </table> | | | | | | | | | Main Circuit Power Supply AC/DC Input Selection | | n.□X□□ | 0 | Input AC power as the main circuit power supply using the L1, L2, and L3 terminals (do not use shared converter). | 1 | Input DC power as the main circuit power supply using the B1/⊕ and ⊖ 2 terminals or the B1 and ⊖ 2 terminals (use an external converter or the shared converter). | | | | | | |
| | Main Circuit Power Supply AC/DC Input Selection | | | | | | | | | | | | | | | | | | | | | |
| | n.□X□□ | 0 | Input AC power as the main circuit power supply using the L1, L2, and L3 terminals (do not use shared converter). | | | | | | | | | | | | | | | | | | | |
| | | 1 | Input DC power as the main circuit power supply using the B1/⊕ and ⊖ 2 terminals or the B1 and ⊖ 2 terminals (use an external converter or the shared converter). | | | | | | | | | | | | | | | | | | | |
| | <table border="1"> <thead> <tr> <th colspan="2">Warning Code Output Selection</th> </tr> </thead> <tbody> <tr> <td rowspan="2">n.X□□□</td> <td>0</td> <td>Output only alarm codes on the ALO1, ALO2, and ALO3 terminals.</td> </tr> <tr> <td>1</td> <td>Output both warning codes and alarm codes on the ALO1, ALO2, and ALO3 terminals. However, while a warning code is being output, the ALM (Servo Alarm) output signal will remain ON (normal state).</td> </tr> </tbody> </table> | | | | | | | | | Warning Code Output Selection | | n.X□□□ | 0 | Output only alarm codes on the ALO1, ALO2, and ALO3 terminals. | 1 | Output both warning codes and alarm codes on the ALO1, ALO2, and ALO3 terminals. However, while a warning code is being output, the ALM (Servo Alarm) output signal will remain ON (normal state). | | | | | | |
| | Warning Code Output Selection | | | | | | | | | | | | | | | | | | | | | |
| | n.X□□□ | 0 | Output only alarm codes on the ALO1, ALO2, and ALO3 terminals. | | | | | | | | | | | | | | | | | | | |
| 1 | | Output both warning codes and alarm codes on the ALO1, ALO2, and ALO3 terminals. However, while a warning code is being output, the ALM (Servo Alarm) output signal will remain ON (normal state). | | | | | | | | | | | | | | | | | | | | |

Continued on next page.

Continued from previous page.

| Parameter No. | Size | Name | Setting Range | Setting Unit | Default Setting | Applicable Motors | When Enabled | Classification | Reference | |
|---------------|--------|-----------------------------------|---|---|-----------------|-------------------|---------------|----------------|--------------------------|--|
| Pn002 | 2 | Application Function Selections 2 | 0000h to 4213h | – | 0000h | – | After restart | Setup | *1 | |
| | | | Speed/Position Control Option (T-REF Input Allocation) | | | | | | Applicable Motors | |
| | n.□□□X | | 0 | Do not use T-REF. | | | | All | | |
| | | | 1 | Use T-REF as an external torque limit input. | | | | | | |
| | | | 2 | Use T-REF as a torque feedback input. | | | | | | |
| | | | 3 | Use T-REF as an external torque limit input when /P-CL or /N-CL is ON. | | | | | | |
| | | | Torque Control Option (V-REF Input Allocation) | | | | | | Applicable Motors | |
| | n.□□X□ | | 0 | Do not use V-REF. | | | | All | | |
| | | | 1 | Use V-REF as an external speed limit input. | | | | | | |
| | | | Encoder Usage | | | | | | Applicable Motors | |
| | n.□X□□ | | 0 | Use the encoder according to encoder specifications. | | | | All | | |
| | | | 1 | Use the encoder as an incremental encoder. | | | | | | |
| | | | 2 | Use the encoder as a single-turn absolute encoder. | | | | Rotary | | |
| | | | External Encoder Usage | | | | | | Applicable Motors | |
| | n.X□□□ | | 0 | Do not use an external encoder. | | | | Rotary | | |
| | | | 1 | The external encoder moves in the forward direction for CCW motor rotation. | | | | | | |
| | | | 2 | Reserved setting (Do not use.) | | | | | | |
| | | | 3 | The external encoder moves in the reverse direction for CCW motor rotation. | | | | | | |
| | | | 4 | Reserved setting (Do not use.) | | | | | | |

Continued on next page.

5.1 SERVOPACKs with Analog Voltage/Pulse Train References

5.1.2 List of Parameters

Continued from previous page.

| Parameter No. | Size | Name | Setting Range | Setting Unit | Default Setting | Applicable Motors | When Enabled | Classification | Reference | | |
|---------------|--------|--|---|-------------------------------------|-----------------|-------------------|--------------|----------------|-----------|--|--|
| Pn006 | 2 | Application Function Selections 6 | 0000h to 105Fh | – | 0002h | All | Immediately | Setup | *1 | | |
| | n.□□XX | Analog Monitor 1 Signal Selection | | | | | | | | | |
| | | 00 | Motor speed (1 V/1,000 min ⁻¹) Motor speed (1 V/1,000 mm/s) | | | | | | | | |
| | | 01 | Speed reference (1 V/1,000 min ⁻¹) Speed reference (1 V/1,000 mm/s) | | | | | | | | |
| | | 02 | Torque reference (1 V/100% rated torque) Force reference (1 V/100% rated force) | | | | | | | | |
| | | 03 | Position deviation (0.05 V/reference unit) | | | | | | | | |
| | | 04 | Position amplifier deviation (after electronic gear) (0.05 V/encoder pulse unit) | | | | | | | | |
| | | | Position amplifier deviation (after electronic gear) (0.05 V/linear encoder pulse unit) | | | | | | | | |
| | | 05 | Position reference speed (1 V/1,000 min ⁻¹) | | | | | | | | |
| | | | Position reference speed (1 V/1,000 mm/s) | | | | | | | | |
| | | 06 | Reserved setting (Do not use.) | | | | | | | | |
| | | 07 | Load-motor position deviation (0.01 V/reference unit) | | | | | | | | |
| | | 08 | Positioning completion (positioning completed: 5 V, positioning not completed: 0 V) | | | | | | | | |
| | | 09 | Speed feedforward (1 V/1,000 min ⁻¹) | | | | | | | | |
| | | | Speed feedforward (1 V/1,000 mm/s) | | | | | | | | |
| | | 0A | Torque feedforward (1 V/100% rated torque) | | | | | | | | |
| | | | Force feedforward (1 V/100% rated force) | | | | | | | | |
| | | 0B | Active gain (1st gain: 1 V, 2nd gain: 2 V) | | | | | | | | |
| | | 0C | Completion of position reference distribution (completed: 5 V, not completed: 0 V) | | | | | | | | |
| | | 0D | External encoder speed (1 V/1,000 min ⁻¹ : value at the motor shaft) | | | | | | | | |
| | | 0E | Reserved setting (Do not use.) | | | | | | | | |
| | | 0F | Reserved setting (Do not use.) | | | | | | | | |
| | | 10 | Main circuit DC voltage | | | | | | | | |
| | | 11 to 24 | Reserved settings (Do not use.) | | | | | | | | |
| | | 25 | Position deviation after position reference filter (0.05 V/reference unit) | | | | | | | | |
| | | 26 to 5F | Reserved settings (Do not use.) | | | | | | | | |
| | | n.□X□□ | | Reserved parameter (Do not change.) | | | | | | | |
| | | n.X□□□ | | Reserved parameter (Do not change.) | | | | | | | |

Continued on next page.

Continued from previous page.

| Parameter No. | Size | Name | Setting Range | Setting Unit | Default Setting | Applicable Motors | When Enabled | Classification | Reference | | |
|---------------|--------|--|---|--------------|-----------------|-------------------|--------------|----------------|-----------|--|--|
| Pn007 | 2 | Application Function Selections 7 | 0000h to 105Fh | - | 0000h | All | Immediately | Setup | *1 | | |
| | n.□□XX | Analog Monitor 2 Signal Selection | | | | | | | | | |
| | | 00 | Motor speed (1 V/1,000 min ⁻¹) Motor speed (1 V/1,000 mm/s) | | | | | | | | |
| | | 01 | Speed reference (1 V/1,000 min ⁻¹) Speed reference (1 V/1,000 mm/s) | | | | | | | | |
| | | 02 | Torque reference (1 V/100% rated torque) Force reference (1 V/100% rated force) | | | | | | | | |
| | | 03 | Position deviation (0.05 V/reference unit) | | | | | | | | |
| | | 04 | Position amplifier deviation (after electronic gear) (0.05 V/encoder pulse unit) Position amplifier deviation (after electronic gear) (0.05 V/linear encoder pulse unit) | | | | | | | | |
| | | 05 | Position reference speed (1 V/1,000 min ⁻¹) Position reference speed (1 V/1,000 mm/s) | | | | | | | | |
| | | 06 | Reserved setting (Do not use.) | | | | | | | | |
| | | 07 | Load-motor position deviation (0.01 V/reference unit) | | | | | | | | |
| | | 08 | Positioning completion (positioning completed: 5 V, positioning not completed: 0 V) | | | | | | | | |
| | | 09 | Speed feedforward (1 V/1,000 min ⁻¹) Speed feedforward (1 V/1,000 mm/s) | | | | | | | | |
| | | 0A | Torque feedforward (1 V/100% rated torque) Force feedforward (1 V/100% rated force) | | | | | | | | |
| | | 0B | Active gain (1st gain: 1 V, 2nd gain: 2 V) | | | | | | | | |
| | | 0C | Completion of position reference distribution (completed: 5 V, not completed: 0 V) | | | | | | | | |
| | | 0D | External encoder speed (1 V/1,000 min ⁻¹ : value at the motor shaft) | | | | | | | | |
| | | 0E | Reserved setting (Do not use.) | | | | | | | | |
| | | 0F | Reserved setting (Do not use.) | | | | | | | | |
| | | 10 | Main circuit DC voltage | | | | | | | | |
| | | 11 to 24 | Reserved settings (Do not use.) | | | | | | | | |
| | | 25 | Position deviation after position reference filter (0.05 V/reference unit) | | | | | | | | |
| | | 26 to 5F | Reserved settings (Do not use.) | | | | | | | | |
| | | n.□X□□ | Reserved parameter (Do not change.) | | | | | | | | |
| | | n.X□□□ | Reserved parameter (Do not change.) | | | | | | | | |

Continued on next page.

5.1 SERVOPACKs with Analog Voltage/Pulse Train References

5.1.2 List of Parameters

Continued from previous page.

| Parameter No. | Size | Name | Setting Range | Setting Unit | Default Setting | Applicable Motors | When Enabled | Classification | Reference | |
|---------------|--------|--|--|--|-----------------|-------------------|---------------|----------------|-----------|--|
| Pn008 | 2 | Application Function Selections 8 | 0000h to 7121h | - | 0000h | Rotary | After restart | Setup | *1 | |
| | n.□□□X | | Low Battery Voltage Alarm/Warning Selection | | | | | | | |
| | | | 0 | Output alarm (A.830) for low battery voltage. | | | | | | |
| | | | 1 | Output warning (A.930) for low battery voltage. | | | | | | |
| | n.□□X□ | | Function Selection for Undervoltage | | | | | | | |
| | | | 0 | Do not detect undervoltage. | | | | | | |
| | | | 1 | Detect undervoltage warning and limit torque at host controller. | | | | | | |
| | | | 2 | Detect undervoltage warning and limit torque with Pn424 and Pn425 (i.e., only in SERVOPACK). | | | | | | |
| | n.□X□□ | | Warning Detection Selection | | | | | | | |
| | | | 0 | Detect warnings. | | | | | | |
| | | 1 | Do not detect warnings except for A.971. | | | | | | | |
| n.X□□□ | | Reserved parameter (Do not change.) | | | | | | | | |
| Pn009 | 2 | Application Function Selections 9 | 0000h to 0121h | - | 0010h | All | After restart | Tuning | *1 | |
| | n.□□□X | | Reserved parameter (Do not change.) | | | | | | | |
| | n.□□X□ | | Current Control Mode Selection | | | | | | | |
| | | | 0 | Use current control mode 1. | | | | | | |
| | | | 1 | <ul style="list-style-type: none"> SERVOPACK Models SGD7S-R70A, -R90A, -1R6A, -2R8A, -5R5A, and -7R6A: Use current control mode 1. SERVOPACK Models SGD7S-120A, -180A, -200A, -330A, -470A, -550A, -590A, and -780A: Use current control mode 2. | | | | | | |
| | | | 2 | Use current control mode 2. | | | | | | |
| | n.□X□□ | | Speed Detection Method Selection | | | | | | | |
| | | | 0 | Use speed detection 1. | | | | | | |
| | | | 1 | Use speed detection 2. | | | | | | |
| | n.X□□□ | | Reserved parameter (Do not change.) | | | | | | | |

Continued on next page.

Continued from previous page.

| Parameter No. | Size | Name | Setting Range | Setting Unit | Default Setting | Applicable Motors | When Enabled | Classification | Reference | |
|---------------|-------------------------------------|---|--|--------------|-----------------|-------------------|---------------|----------------|-----------|--|
| Pn00A | 2 | Application Function Selections A | 0000h to 1044h | - | 0001h | All | After restart | Setup | *1 | |
| | n.□□□X | Motor Stopping Method for Group 2 Alarms | | | | | | | | |
| | | 0 | Apply the dynamic brake or coast the motor to a stop (use the stopping method set in Pn001 = n.□□□X). | | | | | | | |
| | | 1 | Decelerate the motor to a stop using the torque set in Pn406 as the maximum torque. Use the setting of Pn001 = n.□□□X for the status after stopping. | | | | | | | |
| | | 2 | Decelerate the motor to a stop using the torque set in Pn406 as the maximum torque and then let the motor coast. | | | | | | | |
| | | 3 | Decelerate the motor to a stop using the deceleration time set in Pn30A. Use the setting of Pn001 = n.□□□X for the status after stopping. | | | | | | | |
| | 4 | Decelerate the motor to a stop using the deceleration time set in Pn30A and then let the motor coast. | | | | | | | | |
| | n.□□□□ | Stopping Method for Forced Stops | | | | | | | | |
| | | 0 | Apply the dynamic brake or coast the motor to a stop (use the stopping method set in Pn001 = n.□□□X). | | | | | | | |
| | | 1 | Decelerate the motor to a stop using the torque set in Pn406 as the maximum torque. Use the setting of Pn001 = n.□□□X for the status after stopping. | | | | | | | |
| | | 2 | Decelerate the motor to a stop using the torque set in Pn406 as the maximum torque and then let the motor coast. | | | | | | | |
| | | 3 | Decelerate the motor to a stop using the deceleration time set in Pn30A. Use the setting of Pn001 = n.□□□X for the status after stopping. | | | | | | | |
| | 4 | Decelerate the motor to a stop using the deceleration time set in Pn30A and then let the motor coast. | | | | | | | | |
| | n.□X□□ | Reserved parameter (Do not change.) | | | | | | | | |
| n.X□□□ | Reserved parameter (Do not change.) | | | | | | | | | |
| Pn00B | 2 | Application Function Selections B | 0000h to 1121h | - | 0000h | All | After restart | Setup | *1 | |
| | n.□□□X | Operator Parameter Display Selection | | | | | | | | |
| | | 0 | Display only setup parameters. | | | | | | | |
| | 1 | Display all parameters. | | | | | | | | |
| | n.□□□□ | Motor Stopping Method for Group 2 Alarms | | | | | | | | |
| | | 0 | Stop the motor by setting the speed reference to 0. | | | | | | | |
| | | 1 | Apply the dynamic brake or coast the motor to a stop (use the stopping method set in Pn001 = n.□□□X). | | | | | | | |
| | 2 | Set the stopping method with Pn00A = n.□□□X. | | | | | | | | |
| | n.□X□□ | Power Input Selection for Three-phase SERVOPACK | | | | | | | | |
| | | 0 | Use a three-phase power supply input. | | | | | | | |
| | 1 | Use a three-phase power supply input as a single-phase power supply input. | | | | | | | | |
| n.X□□□ | Reserved parameter (Do not change.) | | | | | | | | | |

Continued on next page.

5.1 SERVOPACKs with Analog Voltage/Pulse Train References

5.1.2 List of Parameters

Continued from previous page.

| Parameter No. | Size | Name | Setting Range | Setting Unit | Default Setting | Applicable Motors | When Enabled | Classification | Reference | | |
|---------------|--------|--|--|--|-----------------|-------------------|---------------|-------------------|-----------|--|--|
| Pn00C | 2 | Application Function Selections C | 0000h to 0131h | – | 0000h | – | After restart | Setup | *1 | | |
| | n.□□□X | | Function Selection for Test without a Motor | | | | | Applicable Motors | | | |
| | | | 0 | Disable tests without a motor. | | | | All | | | |
| | | | 1 | Enable tests without a motor. | | | | | | | |
| | n.□□X□ | | Encoder Resolution for Tests without a Motor | | | | | Applicable Motors | | | |
| | | | 0 | Use 13 bits. | | | | Rotary | | | |
| | | | 1 | Use 20 bits. | | | | | | | |
| | | | 2 | Use 22 bits. | | | | | | | |
| | | | 3 | Use 24 bits. | | | | | | | |
| | n.□X□□ | | Encoder Type Selection for Tests without a Motor | | | | | Applicable Motors | | | |
| | | 0 | Use an incremental encoder. | | | | All | | | | |
| | | 1 | Use an absolute encoder. | | | | | | | | |
| n.X□□□ | | Reserved parameter (Do not change.) | | | | | | | | | |
| Pn00D | 2 | Application Function Selections D | 0000h to 1001h | – | 0000h | All | After restart | Setup | *1 | | |
| | n.□□□X | | Reserved parameter (Do not change.) | | | | | | | | |
| | n.□□X□ | | Reserved parameter (Do not change.) | | | | | | | | |
| | n.□X□□ | | Reserved parameter (Do not change.) | | | | | | | | |
| | n.X□□□ | | Overtravel Warning Detection Selection | | | | | | | | |
| | | | 0 | Do not detect overtravel warnings. | | | | | | | |
| | | 1 | Detect overtravel warnings. | | | | | | | | |
| Pn00F | 2 | Application Function Selections F | 0000h to 2011h | – | 0000h | All | After restart | Setup | *1 | | |
| | n.□□□X | | Preventative Maintenance Warning Selection | | | | | | | | |
| | | | 0 | Do not detect preventative maintenance warnings. | | | | | | | |
| | | | 1 | Detect preventative maintenance warnings. | | | | | | | |
| | n.□□X□ | | Reserved parameter (Do not change.) | | | | | | | | |
| | n.□X□□ | | Reserved parameter (Do not change.) | | | | | | | | |
| | n.X□□□ | | Reserved parameter (Do not change.) | | | | | | | | |
| Pn010 | 2 | Axis Address Selection for UART/USB Communications | 0000h to 007Fh | – | 0001h | All | After restart | Setup | – | | |
| Pn021 | 2 | Reserved parameter (Do not change.) | – | – | 0000h | All | – | – | – | | |
| Pn022 | 2 | Reserved parameter (Do not change.) | – | – | 0000h | All | – | – | – | | |

Continued on next page.

Continued from previous page.

| Parameter No. | Size | Name | Setting Range | Setting Unit | Default Setting | Applicable Motors | When Enabled | Classification | Reference | |
|---------------|--------|---|---|--|-----------------|-------------------|---------------|----------------|-----------|-------------------|
| Pn040 | 2 | Σ-V Compatible Function Switch | 0000h to 2111h | – | 0000h | – | After restart | Setup | – | |
| | n.□□□X | | Reserved parameter (Do not change.) | | | | | | | |
| | n.□□□□ | | Encoder Resolution Compatibility Selection | | | | | | | Applicable Motors |
| | | | 0 | Use the encoder resolution of the Servomotor. | | | | | Rotary | |
| | | | 1 | Use a resolution of 20 bits when connected to an SGM7J, SGM7A, SGM7P, SGM7G, SGM7E, or SGM7F Servomotor. | | | | | | |
| | n.□X□□ | | Reserved parameter (Do not change.) | | | | | | | |
| n.X□□□ | | Reserved parameter (Do not change.) | | | | | | | | |
| Pn080 | 2 | Application Function Selections 80 | 0000h to 1111h | – | 0000h | Linear | After restart | Setup | *1 | |
| | n.□□□X | | Polarity Sensor Selection | | | | | | | |
| | | | 0 | Use polarity sensor. | | | | | | |
| | | | 1 | Do not use polarity sensor. | | | | | | |
| | n.□□□□ | | Motor Phase Sequence Selection | | | | | | | |
| | | | 0 | Set a phase-A lead as a phase sequence of U, V, and W. | | | | | | |
| | | 1 | Set a phase-B lead as a phase sequence of U, V, and W. | | | | | | | |
| n.□X□□ | | Reserved parameter (Do not change.) | | | | | | | | |
| n.X□□□ | | Calculation Method for Maximum Speed or Encoder Output Pulses | | | | | | | | |
| | | 0 | Calculate the encoder output pulse setting for a fixed maximum speed. | | | | | | | |
| | | 1 | Calculate the maximum speed for a fixed encoder output pulse setting. | | | | | | | |
| Pn081 | 2 | Application Function Selections 81 | 0000h to 1111h | – | 0000h | All | After restart | Setup | *1 | |
| | n.□□□X | | Phase-C Pulse Output Selection | | | | | | | |
| | | | 0 | Output phase-C pulses only in the forward direction. | | | | | | |
| | | | 1 | Output phase-C pulses in both the forward and reverse directions. | | | | | | |
| | n.□□X□ | | Reserved parameter (Do not change.) | | | | | | | |
| | n.□X□□ | | Reserved parameter (Do not change.) | | | | | | | |
| n.X□□□ | | Reserved parameter (Do not change.) | | | | | | | | |
| Pn100 | 2 | Speed Loop Gain | 10 to 20,000 | 0.1 Hz | 400 | All | Immediately | Tuning | *1 | |
| Pn101 | 2 | Speed Loop Integral Time Constant | 15 to 51,200 | 0.01 ms | 2000 | All | Immediately | Tuning | *1 | |
| Pn102 | 2 | Position Loop Gain | 10 to 20,000 | 0.1/s | 400 | All | Immediately | Tuning | *1 | |
| Pn103 | 2 | Moment of Inertia Ratio | 0 to 20,000 | 1% | 100 | All | Immediately | Tuning | *1 | |
| Pn104 | 2 | Second Speed Loop Gain | 10 to 20,000 | 0.1 Hz | 400 | All | Immediately | Tuning | *1 | |
| Pn105 | 2 | Second Speed Loop Integral Time Constant | 15 to 51,200 | 0.01 ms | 2000 | All | Immediately | Tuning | *1 | |
| Pn106 | 2 | Second Position Loop Gain | 10 to 20,000 | 0.1/s | 400 | All | Immediately | Tuning | *1 | |

Continued on next page.

5.1 SERVOPACKs with Analog Voltage/Pulse Train References

5.1.2 List of Parameters

Continued from previous page.

| Parameter No. | Size | Name | Setting Range | Setting Unit | Default Setting | Applicable Motors | When Enabled | Classification | Reference | |
|---------------|--------|---|----------------------------------|--|-----------------|-------------------|---------------|----------------|---------------------|--|
| Pn109 | 2 | Feedforward | 0 to 100 | 1% | 0 | All | Immediately | Tuning | *1 | |
| Pn10A | 2 | Feedforward Filter Time Constant | 0 to 6,400 | 0.01 ms | 0 | All | Immediately | Tuning | *1 | |
| Pn10B | 2 | Gain Application Selections | 0000h to 5334h | - | 0004h | All | - | Setup | *1 | |
| | | | Mode Switching Selection | | | | | | When Enabled | |
| | n.□□□X | | 0 | Use the internal torque reference as the condition (level setting: Pn10C). | | | | Immediately | | |
| | | | 1 | Use the speed reference as the condition (level setting: Pn10D). | | | | | | |
| | | | | Use the speed reference as the condition (level setting: Pn181). | | | | | | |
| | | | 2 | Use the acceleration reference as the condition (level setting: Pn10E). | | | | | | |
| | | | | Use the acceleration reference as the condition (level setting: Pn182). | | | | | | |
| | | | 3 | Use the position deviation as the condition (level setting: Pn10F). | | | | | | |
| | | | 4 | Do not use mode switching. | | | | | | |
| | | | Speed Loop Control Method | | | | | | When Enabled | |
| n.□□X□ | | 0 | PI control | | | | After restart | | | |
| | | 1 | I-P control | | | | | | | |
| | | 2 to 3 | Reserved settings (Do not use.) | | | | | | | |
| n.□X□□ | | Reserved parameter (Do not change.) | | | | | | | | |
| n.X□□□ | | Reserved parameter (Do not change.) | | | | | | | | |
| Pn10C | 2 | Mode Switching Level for Torque Reference | 0 to 800 | 1% | 200 | All | Immediately | Tuning | *1 | |
| Pn10D | 2 | Mode Switching Level for Speed Reference | 0 to 10,000 | 1 min ⁻¹ | 0 | Rotary | Immediately | Tuning | *1 | |
| Pn10E | 2 | Mode Switching Level for Acceleration | 0 to 30,000 | 1 min ⁻¹ /s | 0 | Rotary | Immediately | Tuning | *1 | |
| Pn10F | 2 | Mode Switching Level for Position Deviation | 0 to 10,000 | 1 reference unit | 0 | All | Immediately | Tuning | *1 | |
| Pn11F | 2 | Position Integral Time Constant | 0 to 50,000 | 0.1 ms | 0 | All | Immediately | Tuning | *1 | |
| Pn121 | 2 | Friction Compensation Gain | 10 to 1,000 | 1% | 100 | All | Immediately | Tuning | *1 | |
| Pn122 | 2 | Second Friction Compensation Gain | 10 to 1,000 | 1% | 100 | All | Immediately | Tuning | *1 | |
| Pn123 | 2 | Friction Compensation Coefficient | 0 to 100 | 1% | 0 | All | Immediately | Tuning | *1 | |
| Pn124 | 2 | Friction Compensation Frequency Correction | -10,000 to 10,000 | 0.1 Hz | 0 | All | Immediately | Tuning | *1 | |
| Pn125 | 2 | Friction Compensation Gain Correction | 1 to 1,000 | 1% | 100 | All | Immediately | Tuning | *1 | |
| Pn131 | 2 | Gain Switching Time 1 | 0 to 65,535 | 1 ms | 0 | All | Immediately | Tuning | *1 | |
| Pn132 | 2 | Gain Switching Time 2 | 0 to 65,535 | 1 ms | 0 | All | Immediately | Tuning | *1 | |
| Pn135 | 2 | Gain Switching Waiting Time 1 | 0 to 65,535 | 1 ms | 0 | All | Immediately | Tuning | *1 | |
| Pn136 | 2 | Gain Switching Waiting Time 2 | 0 to 65,535 | 1 ms | 0 | All | Immediately | Tuning | *1 | |

Continued on next page.

Continued from previous page.

| Parameter No. | Size | Name | Setting Range | Setting Unit | Default Setting | Applicable Motors | When Enabled | Classification | Reference | |
|---------------|--------|---|---|--------------|---|-------------------|--------------|----------------|-----------|----|
| Pn139 | 2 | Automatic Gain Switching Selections 1 | 0000h to 0052h | - | 0000h | All | Immediately | Tuning | *1 | |
| | n.□□□X | Gain Switching Selection | | 0 | Use manual gain switching. The gain is switched manually with the /G-SEL (Gain Selection) signal. | | | | | |
| | | | | 1 | Reserved setting (Do not use.) | | | | | |
| | | | | 2 | Use automatic gain switching pattern 1. The gain settings 1 switch automatically to 2 when switching condition A is satisfied. The gain settings 2 switch automatically to 1 when switching condition A is not satisfied. | | | | | |
| | n.□□□□ | Gain Switching Condition A | | 0 | /COIN (Positioning Completion Output) signal turns ON. | | | | | |
| | | | | 1 | /COIN (Positioning Completion Output) signal turns OFF. | | | | | |
| | | | | 2 | /NEAR (Near Output) signal turns ON. | | | | | |
| | | | | 3 | /NEAR (Near Output) signal turns OFF. | | | | | |
| | | | | 4 | Position reference filter output is 0 and reference pulse input is OFF. | | | | | |
| | | | | 5 | Position reference pulse input is ON. | | | | | |
| | n.□X□□ | Reserved parameter (Do not change.) | | | | | | | | |
| | n.X□□□ | Reserved parameter (Do not change.) | | | | | | | | |
| Pn13D | 2 | Current Gain Level | 100 to 2,000 | 1% | 2000 | All | Immediately | Tuning | *1 | |
| Pn13F | 2 | Less-Deviation Control 2 Second Position Integral Time Constant | 0 to 50,000 | 0.1 ms | 0 | All | Immediately | Tuning | - | |
| Pn140 | 2 | Model Following Control-Related Selections | 0000h to 1121h | - | 0100h | All | Immediately | Tuning | *1 | |
| | n.□□□X | Model Following Control Selection | | 0 | Do not use model following control. | | | | | |
| | | | | 1 | Use model following control. | | | | | |
| | n.□□□□ | Vibration Suppression Selection | | 0 | Do not perform vibration suppression. | | | | | |
| | | | | 1 | Perform vibration suppression for a specific frequency. | | | | | |
| | | | | 2 | Perform vibration suppression for two specific frequencies. | | | | | |
| | n.□X□□ | Vibration Suppression Adjustment Selection | | 0 | Do not adjust vibration suppression automatically during execution of autotuning without a host reference, autotuning with a host reference, and custom tuning. | | | | | |
| | | | | 1 | Adjust vibration suppression automatically during execution of autotuning without a host reference, autotuning with a host reference, and custom tuning. | | | | | |
| | n.X□□□ | Speed Feedforward (VFF)/Torque Feedforward (TFF) Selection | | 0 | Do not use model following control and speed/torque feedforward together. | | | | | |
| | | | | 1 | Use model following control and speed/torque feedforward together. | | | | | |
| | Pn141 | 2 | Model Following Control Gain | 10 to 20,000 | 0.1/s | 500 | All | Immediately | Tuning | *1 |
| | Pn142 | 2 | Model Following Control Gain Correction | 500 to 2,000 | 0.1% | 1000 | All | Immediately | Tuning | *1 |
| Pn143 | 2 | Model Following Control Bias in the Forward Direction | 0 to 10,000 | 0.1% | 1000 | All | Immediately | Tuning | *1 | |

Continued on next page.

5.1 SERVOPACKs with Analog Voltage/Pulse Train References

5.1.2 List of Parameters

Continued from previous page.

| Parameter No. | Size | Name | Setting Range | Setting Unit | Default Setting | Applicable Motors | When Enabled | Classification | Reference | |
|---------------|--------|--|---|--|-----------------|-------------------|---------------|----------------|-----------|--|
| Pn144 | 2 | Model Following Control Bias in the Reverse Direction | 0 to 10,000 | 0.1% | 1000 | All | Immediately | Tuning | *1 | |
| Pn145 | 2 | Vibration Suppression 1 Frequency A | 10 to 2,500 | 0.1 Hz | 500 | All | Immediately | Tuning | *1 | |
| Pn146 | 2 | Vibration Suppression 1 Frequency B | 10 to 2,500 | 0.1 Hz | 700 | All | Immediately | Tuning | *1 | |
| Pn147 | 2 | Model Following Control Speed Feedforward Compensation | 0 to 10,000 | 0.1% | 1000 | All | Immediately | Tuning | *1 | |
| Pn148 | 2 | Second Model Following Control Gain | 10 to 20,000 | 0.1/s | 500 | All | Immediately | Tuning | *1 | |
| Pn149 | 2 | Second Model Following Control Gain Correction | 500 to 2,000 | 0.1% | 1000 | All | Immediately | Tuning | *1 | |
| Pn14A | 2 | Vibration Suppression 2 Frequency | 10 to 2,000 | 0.1 Hz | 800 | All | Immediately | Tuning | *1 | |
| Pn14B | 2 | Vibration Suppression 2 Correction | 10 to 1,000 | 1% | 100 | All | Immediately | Tuning | *1 | |
| Pn14F | 2 | Control-Related Selections | 0000h to 0021h | – | 0021h | All | After restart | Tuning | *1 | |
| | n.□□□X | | Model Following Control Type Selection | | | | | | | |
| | | | 0 | Use model following control type 1. | | | | | | |
| | | | 1 | Use model following control type 2. | | | | | | |
| | n.□□X□ | | Tuning-less Type Selection | | | | | | | |
| | | | 0 | Use tuning-less type 1. | | | | | | |
| | | 1 | Use tuning-less type 2. | | | | | | | |
| | | 2 | Use tuning-less type 3. | | | | | | | |
| n.□X□□ | | Reserved parameter (Do not change.) | | | | | | | | |
| n.X□□□ | | Reserved parameter (Do not change.) | | | | | | | | |
| Pn160 | 2 | Anti-Resonance Control-Related Selections | 0000h to 0011h | – | 0010h | All | Immediately | Tuning | *1 | |
| | n.□□□X | | Anti-Resonance Control Selection | | | | | | | |
| | | | 0 | Do not use anti-resonance control. | | | | | | |
| | | | 1 | Use anti-resonance control. | | | | | | |
| | n.□□X□ | | Anti-Resonance Control Adjustment Selection | | | | | | | |
| | | | 0 | Do not adjust anti-resonance control automatically during execution of autotuning without a host reference, autotuning with a host reference, and custom tuning. | | | | | | |
| | | 1 | Adjust anti-resonance control automatically during execution of autotuning without a host reference, autotuning with a host reference, and custom tuning. | | | | | | | |
| n.□X□□ | | Reserved parameter (Do not change.) | | | | | | | | |
| n.X□□□ | | Reserved parameter (Do not change.) | | | | | | | | |
| Pn161 | 2 | Anti-Resonance Frequency | 10 to 20,000 | 0.1 Hz | 1000 | All | Immediately | Tuning | *1 | |
| Pn162 | 2 | Anti-Resonance Gain Correction | 1 to 1,000 | 1% | 100 | All | Immediately | Tuning | *1 | |
| Pn163 | 2 | Anti-Resonance Damping Gain | 0 to 300 | 1% | 0 | All | Immediately | Tuning | *1 | |

Continued on next page.

Continued from previous page.

| Parameter No. | Size | Name | Setting Range | Setting Unit | Default Setting | Applicable Motors | When Enabled | Classification | Reference | | |
|---------------|--------|---|--|---|-----------------|-------------------|---------------|----------------|---------------|--|--|
| Pn164 | 2 | Anti-Resonance Filter Time Constant 1 Correction | -1,000 to 1,000 | 0.01 ms | 0 | All | Immediately | Tuning | *1 | | |
| Pn165 | 2 | Anti-Resonance Filter Time Constant 2 Correction | -1,000 to 1,000 | 0.01 ms | 0 | All | Immediately | Tuning | *1 | | |
| Pn166 | 2 | Anti-Resonance Damping Gain 2 | 0 to 1,000 | 1% | 0 | All | Immediately | Tuning | *1 | | |
| Pn170 | 2 | Tuning-less Function-Related Selections | 0000h to 2711h | - | 1400h | All | - | Setup | *1 | | |
| | n.□□□X | | Tuning-less Selection | | | | | When Enabled | | | |
| | | | 0 | Disable tuning-less function. | | | | | After restart | | |
| | | | 1 | Enable tuning-less function. | | | | | | | |
| | n.□□X□ | | Speed Control Method | | | | | When Enabled | | | |
| | | | 0 | Use for speed control. | | | | | After restart | | |
| | | | 1 | Use for speed control and use host controller for position control. | | | | | | | |
| | n.□X□□ | | Rigidity Level | | | | | When Enabled | | | |
| | | | 0 to 7 | Set the rigidity level. | | | | | Immediately | | |
| | n.X□□□ | | Tuning-less Load Level | | | | | When Enabled | | | |
| | | 0 to 2 | Set the load level for the tuning-less function. | | | | | Immediately | | | |
| Pn181 | 2 | Mode Switching Level for Speed Reference | 0 to 10,000 | 1 mm/s | 0 | Linear | Immediately | Tuning | *1 | | |
| Pn182 | 2 | Mode Switching Level for Acceleration | 0 to 30,000 | 1 mm/s ² | 0 | Linear | Immediately | Tuning | *1 | | |
| Pn190 | 2 | Less-Deviation Control-Related Switches | 0000h to 1101h | - | 0100h | All | After restart | Setup | - | | |
| | n.□□□X | | Less-Deviation Control Selection | | | | | | | | |
| | | | 0 | Do not use less-deviation control. | | | | | | | |
| | | | 1 | Use less-deviation control. | | | | | | | |
| | n.□□X□ | | Reserved parameter (Do not change.) | | | | | | | | |
| | n.□X□□ | | Reserved parameter (Do not change.) | | | | | | | | |
| n.X□□□ | | Speed Feedforward/Torque Feedforward Selection | | | | | | | | | |
| | | 0 | Less-deviation control and speed/torque feedforward are not used together. | | | | | | | | |
| | | 1 | Less-deviation control and speed/torque feedforward are used together. | | | | | | | | |
| Pn191 | 2 | Less-Deviation Control 1 Feedforward Gain | 0 to 10,000 | 0.1% | 1000 | All | Immediately | Tuning | - | | |
| Pn192 | 2 | Less-Deviation Control 1 Second Feedforward Gain | 0 to 10,000 | 0.1% | 1000 | All | Immediately | Tuning | - | | |
| Pn193 | 2 | Less-Deviation Control 1 Feedforward Filter Time Constant | 0 to 65,535 | 0.01 ms | 30 | All | Immediately | Tuning | - | | |

Continued on next page.

5.1 SERVOPACKs with Analog Voltage/Pulse Train References

5.1.2 List of Parameters

Continued from previous page.

| Parameter No. | Size | Name | Setting Range | Setting Unit | Default Setting | Applicable Motors | When Enabled | Classification | Reference |
|---------------|------|--|--|-----------------------------|-----------------|-------------------|---------------|----------------|-----------|
| Pn195 | 2 | Less-Deviation Function Selection Switches | 0000h to 2113h | – | 2102h | All | After restart | Setup | – |
| | | n.□□□X | Reserved parameter (Do not change.) | | | | | | |
| | | n.□□X□ | Reserved parameter (Do not change.) | | | | | | |
| | | n.□X□□ | Reserved parameter (Do not change.) | | | | | | |
| | | n.X□□□ | Less-Deviation Mode Selection | | | | | | |
| | | 0 | Use Less-Deviation Control 1 Mode when less-deviation control is enabled. (This mode is compatible with the Σ -V-series EX002.) | | | | | | |
| | | 1 | Reserved setting (Do not use.) | | | | | | |
| | | 2 | Use Less-Deviation Control 2 Mode when less-deviation control is enabled. | | | | | | |
| Pn196 | 2 | Less-Deviation Control 2 Speed Feedforward Gain | 0 to 10,000 | 0.1% | 1000 | All | Immediately | Tuning | – |
| Pn197 | 2 | Less-Deviation Control 2 Torque Feedforward Filter Time Constant | 0 to 65,535 | 0.01 ms | 50 | All | Immediately | Tuning | – |
| Pn198 | 2 | Less-Deviation Control 2 Forward Torque Feedforward Gain | 0 to 10,000 | 0.1% | 1000 | All | Immediately | Tuning | – |
| Pn199 | 2 | Less-Deviation Control 2 Reverse Torque Feedforward Gain | 0 to 10,000 | 0.1% | 1000 | All | Immediately | Tuning | – |
| Pn19A | 2 | Less-Deviation Control 2 Incomplete Integration Rate | 0 to 10,000 | 0.01% | 10000 | All | Immediately | Tuning | – |
| Pn19B | 2 | Less-Deviation Control 2 Rotary Servomotor Viscous Friction Compensation Coefficient | 0 to 8,000 | 0.01%/100 min ⁻¹ | 0 | Rotary | Immediately | Tuning | – |
| Pn19C | 2 | Reserved parameter (Do not change.) | – | – | 0 | All | Immediately | Tuning | – |
| Pn19D | 2 | Less-Deviation Control 2 Linear Servomotor Viscous Friction Compensation Coefficient | 0 to 8,000 | 0.01%/100 mm/s | 0 | Linear | Immediately | Tuning | – |
| Pn19E | 2 | Reserved parameter (Do not change.) | – | – | 0 | All | Immediately | Tuning | – |
| Pn19F | 2 | Less-Deviation Control 2 Torque Feedforward Moving Average Time | 0 to 5,100 | 0.1 ms | 0 | All | Immediately | Tuning | – |
| Pn1A4 | 2 | Reserved parameter (Do not change.) | – | – | 36 | – | Immediately | Tuning | – |
| Pn1A5 | 2 | Reserved parameter (Do not change.) | – | – | 0 | – | Immediately | Tuning | – |
| Pn1AE | 2 | Reserved parameter (Do not change.) | – | – | 0 | – | Immediately | Tuning | – |
| Pn1AF | 2 | Reserved parameter (Do not change.) | – | – | 0 | – | Immediately | Tuning | – |

Continued on next page.

Continued from previous page.

| Parameter No. | Size | Name | Setting Range | Setting Unit | Default Setting | Applicable Motors | When Enabled | Classification | Reference | | | | | | | | | | | | | | | | | | | | | | | | | | | | | | | | | | | | | | | | | | | |
|---------------|--|---|---|--------------------------|-----------------|-------------------|---------------|----------------|-----------|--|--|--|---|---|---|--|---|--|---|---|---|---|---|---------------------------------------|---|---|-------------------|--|---|--|---|--|---|---|---|---|-----------------|--|---|---|---|--|---|--|------------------|--|---|--|---|--|---|--|
| Pn200 | 2 | Position Control Reference Form Selections | 0000h to 2236h | – | 0000h | All | After restart | Setup | *1 | | | | | | | | | | | | | | | | | | | | | | | | | | | | | | | | | | | | | | | | | | | |
| | | | <table border="1"> <thead> <tr> <th colspan="2">Reference Pulse Form</th> </tr> </thead> <tbody> <tr> <td>0</td> <td>Sign and pulse train, positive logic.</td> </tr> <tr> <td>1</td> <td>CW and CCW pulse trains, positive logic</td> </tr> <tr> <td>2</td> <td>Two-phase pulse trains with 90° phase differential (phase A and phase B) x1, positive logic</td> </tr> <tr> <td>3</td> <td>Two-phase pulse trains with 90° phase differential (phase A and phase B) x2, positive logic</td> </tr> <tr> <td>4</td> <td>Two-phase pulse trains with 90° phase differential (phase A and phase B) x4, positive logic</td> </tr> <tr> <td>5</td> <td>Sign and pulse train, negative logic.</td> </tr> <tr> <td>6</td> <td>CW and CCW pulse trains, negative logic</td> </tr> </tbody> </table> <table border="1"> <thead> <tr> <th colspan="2">Clear Signal Form</th> </tr> </thead> <tbody> <tr> <td>0</td> <td>Clear position deviation when the signal is at high level.</td> </tr> <tr> <td>1</td> <td>Clear position deviation on the rising edge of the signal.</td> </tr> <tr> <td>2</td> <td>Clear position deviation when the signal is at low level.</td> </tr> <tr> <td>3</td> <td>Clear position deviation on the falling edge of the signal.</td> </tr> </tbody> </table> <table border="1"> <thead> <tr> <th colspan="2">Clear Operation</th> </tr> </thead> <tbody> <tr> <td>0</td> <td>Clear position deviation at a base block (at servo OFF or when alarm occurs).</td> </tr> <tr> <td>1</td> <td>Do not clear position error (cleared only with CLR (Clear Position Deviation) signal).</td> </tr> <tr> <td>2</td> <td>Clear position deviation when an alarm occurs.</td> </tr> </tbody> </table> <table border="1"> <thead> <tr> <th colspan="2">Filter Selection</th> </tr> </thead> <tbody> <tr> <td>0</td> <td>Use the reference input filter for a line-driver signal. (1 Mpps max.)</td> </tr> <tr> <td>1</td> <td>Use the reference input filter for an open-collector signal. (200 kpps max.)</td> </tr> <tr> <td>2</td> <td>Use reference input filter 2 for a line-driver signal. (1 to 4 Mpps)</td> </tr> </tbody> </table> | | | | | | | | Reference Pulse Form | | 0 | Sign and pulse train, positive logic. | 1 | CW and CCW pulse trains, positive logic | 2 | Two-phase pulse trains with 90° phase differential (phase A and phase B) x1, positive logic | 3 | Two-phase pulse trains with 90° phase differential (phase A and phase B) x2, positive logic | 4 | Two-phase pulse trains with 90° phase differential (phase A and phase B) x4, positive logic | 5 | Sign and pulse train, negative logic. | 6 | CW and CCW pulse trains, negative logic | Clear Signal Form | | 0 | Clear position deviation when the signal is at high level. | 1 | Clear position deviation on the rising edge of the signal. | 2 | Clear position deviation when the signal is at low level. | 3 | Clear position deviation on the falling edge of the signal. | Clear Operation | | 0 | Clear position deviation at a base block (at servo OFF or when alarm occurs). | 1 | Do not clear position error (cleared only with CLR (Clear Position Deviation) signal). | 2 | Clear position deviation when an alarm occurs. | Filter Selection | | 0 | Use the reference input filter for a line-driver signal. (1 Mpps max.) | 1 | Use the reference input filter for an open-collector signal. (200 kpps max.) | 2 | Use reference input filter 2 for a line-driver signal. (1 to 4 Mpps) |
| | Reference Pulse Form | | | | | | | | | | | | | | | | | | | | | | | | | | | | | | | | | | | | | | | | | | | | | | | | | | | |
| | 0 | Sign and pulse train, positive logic. | | | | | | | | | | | | | | | | | | | | | | | | | | | | | | | | | | | | | | | | | | | | | | | | | | |
| | 1 | CW and CCW pulse trains, positive logic | | | | | | | | | | | | | | | | | | | | | | | | | | | | | | | | | | | | | | | | | | | | | | | | | | |
| | 2 | Two-phase pulse trains with 90° phase differential (phase A and phase B) x1, positive logic | | | | | | | | | | | | | | | | | | | | | | | | | | | | | | | | | | | | | | | | | | | | | | | | | | |
| | 3 | Two-phase pulse trains with 90° phase differential (phase A and phase B) x2, positive logic | | | | | | | | | | | | | | | | | | | | | | | | | | | | | | | | | | | | | | | | | | | | | | | | | | |
| | 4 | Two-phase pulse trains with 90° phase differential (phase A and phase B) x4, positive logic | | | | | | | | | | | | | | | | | | | | | | | | | | | | | | | | | | | | | | | | | | | | | | | | | | |
| | 5 | Sign and pulse train, negative logic. | | | | | | | | | | | | | | | | | | | | | | | | | | | | | | | | | | | | | | | | | | | | | | | | | | |
| | 6 | CW and CCW pulse trains, negative logic | | | | | | | | | | | | | | | | | | | | | | | | | | | | | | | | | | | | | | | | | | | | | | | | | | |
| | Clear Signal Form | | | | | | | | | | | | | | | | | | | | | | | | | | | | | | | | | | | | | | | | | | | | | | | | | | | |
| | 0 | Clear position deviation when the signal is at high level. | | | | | | | | | | | | | | | | | | | | | | | | | | | | | | | | | | | | | | | | | | | | | | | | | | |
| | 1 | Clear position deviation on the rising edge of the signal. | | | | | | | | | | | | | | | | | | | | | | | | | | | | | | | | | | | | | | | | | | | | | | | | | | |
| | 2 | Clear position deviation when the signal is at low level. | | | | | | | | | | | | | | | | | | | | | | | | | | | | | | | | | | | | | | | | | | | | | | | | | | |
| | 3 | Clear position deviation on the falling edge of the signal. | | | | | | | | | | | | | | | | | | | | | | | | | | | | | | | | | | | | | | | | | | | | | | | | | | |
| | Clear Operation | | | | | | | | | | | | | | | | | | | | | | | | | | | | | | | | | | | | | | | | | | | | | | | | | | | |
| | 0 | Clear position deviation at a base block (at servo OFF or when alarm occurs). | | | | | | | | | | | | | | | | | | | | | | | | | | | | | | | | | | | | | | | | | | | | | | | | | | |
| | 1 | Do not clear position error (cleared only with CLR (Clear Position Deviation) signal). | | | | | | | | | | | | | | | | | | | | | | | | | | | | | | | | | | | | | | | | | | | | | | | | | | |
| | 2 | Clear position deviation when an alarm occurs. | | | | | | | | | | | | | | | | | | | | | | | | | | | | | | | | | | | | | | | | | | | | | | | | | | |
| | Filter Selection | | | | | | | | | | | | | | | | | | | | | | | | | | | | | | | | | | | | | | | | | | | | | | | | | | | |
| | 0 | Use the reference input filter for a line-driver signal. (1 Mpps max.) | | | | | | | | | | | | | | | | | | | | | | | | | | | | | | | | | | | | | | | | | | | | | | | | | | |
| 1 | Use the reference input filter for an open-collector signal. (200 kpps max.) | | | | | | | | | | | | | | | | | | | | | | | | | | | | | | | | | | | | | | | | | | | | | | | | | | | |
| 2 | Use reference input filter 2 for a line-driver signal. (1 to 4 Mpps) | | | | | | | | | | | | | | | | | | | | | | | | | | | | | | | | | | | | | | | | | | | | | | | | | | | |
| Pn205 | 2 | Multiturn Limit | 0 to 65,535 | 1 rev | 65535 | Rotary | After restart | Setup | *1 | | | | | | | | | | | | | | | | | | | | | | | | | | | | | | | | | | | | | | | | | | | |
| Pn207 | 2 | Position Control Function Selections | 0000h to 2210h | – | 1000h | All | After restart | Setup | *1 | | | | | | | | | | | | | | | | | | | | | | | | | | | | | | | | | | | | | | | | | | | |
| | n.□□□X | | Reserved parameter (Do not change.) | | | | | | | | | | | | | | | | | | | | | | | | | | | | | | | | | | | | | | | | | | | | | | | | | |
| | n.□□X□ | | Reserved parameter (Do not change.) | | | | | | | | | | | | | | | | | | | | | | | | | | | | | | | | | | | | | | | | | | | | | | | | | |
| | n.□X□□ | | Reserved parameter (Do not change.) | | | | | | | | | | | | | | | | | | | | | | | | | | | | | | | | | | | | | | | | | | | | | | | | | |
| | | | <table border="1"> <thead> <tr> <th colspan="2">/COIN (Positioning Completion Output) Signal Output Timing</th> </tr> </thead> <tbody> <tr> <td>0</td> <td>Output when the absolute value of the position deviation is the same or less than the setting of Pn522 (Positioning Completed Width).</td> </tr> <tr> <td>1</td> <td>Output when the absolute value of the position error is the same or less than the setting of Pn522 (Positioning Completed Width) and the reference after the position reference filter is 0.</td> </tr> <tr> <td>2</td> <td>Output when the absolute value of the position error is the same or less than the setting of Pn522 (Positioning Completed Width) and the reference input is 0.</td> </tr> </tbody> </table> | | | | | | | | /COIN (Positioning Completion Output) Signal Output Timing | | 0 | Output when the absolute value of the position deviation is the same or less than the setting of Pn522 (Positioning Completed Width). | 1 | Output when the absolute value of the position error is the same or less than the setting of Pn522 (Positioning Completed Width) and the reference after the position reference filter is 0. | 2 | Output when the absolute value of the position error is the same or less than the setting of Pn522 (Positioning Completed Width) and the reference input is 0. | | | | | | | | | | | | | | | | | | | | | | | | | | | | | | | | | | |
| | /COIN (Positioning Completion Output) Signal Output Timing | | | | | | | | | | | | | | | | | | | | | | | | | | | | | | | | | | | | | | | | | | | | | | | | | | | |
| 0 | Output when the absolute value of the position deviation is the same or less than the setting of Pn522 (Positioning Completed Width). | | | | | | | | | | | | | | | | | | | | | | | | | | | | | | | | | | | | | | | | | | | | | | | | | | | |
| 1 | Output when the absolute value of the position error is the same or less than the setting of Pn522 (Positioning Completed Width) and the reference after the position reference filter is 0. | | | | | | | | | | | | | | | | | | | | | | | | | | | | | | | | | | | | | | | | | | | | | | | | | | | |
| 2 | Output when the absolute value of the position error is the same or less than the setting of Pn522 (Positioning Completed Width) and the reference input is 0. | | | | | | | | | | | | | | | | | | | | | | | | | | | | | | | | | | | | | | | | | | | | | | | | | | | |
| n.X□□□ | | | | | | | | | | | | | | | | | | | | | | | | | | | | | | | | | | | | | | | | | | | | | | | | | | | | |
| Pn20A | 4 | Number of External Encoder Scale Pitches | 4 to 1,048,576 | 1 scale pitch/revolution | 32768 | Rotary | After restart | Setup | *1 | | | | | | | | | | | | | | | | | | | | | | | | | | | | | | | | | | | | | | | | | | | |
| Pn20E | 4 | Electronic Gear Ratio (Numerator) | 1 to 1,073,741,824 | 1 | 64 | All | After restart | Setup | *1 | | | | | | | | | | | | | | | | | | | | | | | | | | | | | | | | | | | | | | | | | | | |

Continued on next page.

5.1 SERVOPACKs with Analog Voltage/Pulse Train References

5.1.2 List of Parameters

Continued from previous page.

| Parameter No. | Size | Name | Setting Range | Setting Unit | Default Setting | Applicable Motors | When Enabled | Classification | Reference |
|---------------|--------|---|---|--|-----------------|-------------------|-----------------------------------|----------------|-----------|
| Pn210 | 4 | Electronic Gear Ratio (Denominator) | 1 to 1,073,741,824 | 1 | 1 | All | After restart | Setup | *1 |
| Pn212 | 4 | Number of Encoder Output Pulses | 16 to 1,073,741,824 | 1 P/Rev | 2048 | Rotary | After restart | Setup | *1 |
| Pn216 | 2 | Position Reference Acceleration/Deceleration Time Constant | 0 to 65,535 | 0.1 ms | 0 | All | Immediately after the motor stops | Setup | *1 |
| Pn217 | 2 | Average Position Reference Movement Time | 0 to 10,000 | 0.1 ms | 0 | All | Immediately after the motor stops | Setup | *1 |
| Pn218 | 2 | Reference Pulse Input Multiplier | 1 to 100 | × 1 | 1 | All | Immediately | Setup | *1 |
| Pn22A | 2 | Fully-closed Control Selections | 0000h to 1003h | – | 0000h | Rotary | After restart | Setup | *1 |
| | n.□□□X | | Reserved parameter (Do not change.) | | | | | | |
| | n.□□X□ | | Reserved parameter (Do not change.) | | | | | | |
| | n.□X□□ | | Reserved parameter (Do not change.) | | | | | | |
| | n.X□□□ | | Fully-closed Control Speed Feedback Selection | | | | | | |
| | | 0 | Use motor encoder speed. | | | | | | |
| | | 1 | Use external encoder speed. | | | | | | |
| Pn234 | 2 | Second Position Reference Acceleration/Deceleration Time Constant | 0 to 65,535 | 0.1 ms | 0 | All | Immediately | Setup | – |
| Pn281 | 2 | Encoder Output Resolution | 1 to 4,096 | 1 edge/pitch | 20 | All | After restart | Setup | *1 |
| Pn282 | 4 | Linear Encoder Scale Pitch | 0 to 6,553,600 | 0.01 μm | 0 | Linear | After restart | Setup | *1 |
| Pn300 | 2 | Speed Reference Input Gain | 150 to 3,000 | 0.01 V/Rated motor speed | 600 | All | Immediately | Setup | *1 |
| Pn301 | 2 | Internal Set Speed 1 | 0 to 10,000 | Rotary: 1 min ⁻¹ Direct Drive: 0.1 min ⁻¹ | 100 | Rotary | Immediately | Setup | *1 |
| Pn302 | 2 | Internal Set Speed 2 | 0 to 10,000 | Rotary: 1 min ⁻¹ Direct Drive: 0.1 min ⁻¹ | 200 | Rotary | Immediately | Setup | *1 |
| Pn303 | 2 | Internal Set Speed 3 | 0 to 10,000 | Rotary: 1 min ⁻¹ Direct Drive: 0.1 min ⁻¹ | 300 | Rotary | Immediately | Setup | *1 |
| Pn304 | 2 | Jogging Speed | 0 to 10,000 | Rotary: 1 min ⁻¹ Direct Drive: 0.1 min ⁻¹ | 500 | Rotary | Immediately | Setup | *1 |
| Pn305 | 2 | Soft Start Acceleration Time | 0 to 10,000 | 1 ms | 0 | All | Immediately | Setup | *1 |
| Pn306 | 2 | Soft Start Deceleration Time | 0 to 10,000 | 1 ms | 0 | All | Immediately | Setup | *1 |

Continued on next page.

Continued from previous page.

| Parameter No. | Size | Name | Setting Range | Setting Unit | Default Setting | Applicable Motors | When Enabled | Classification | Reference | | | | | | | | | | | | |
|---------------|-------------------------------------|--|----------------|--|-----------------|-------------------|---------------|----------------|-----------|--|-------------------------------|--|--------|---|--------------------------|--------|---|--|--------|---|---|
| Pn307 | 2 | Speed Reference Filter Time Constant | 0 to 65,535 | 0.01 ms | 40 | All | Immediately | Setup | *1 | | | | | | | | | | | | |
| Pn308 | 2 | Speed Feedback Filter Time Constant | 0 to 65,535 | 0.01 ms | 0 | All | Immediately | Setup | *1 | | | | | | | | | | | | |
| Pn30A | 2 | Deceleration Time for Servo OFF and Forced Stops | 0 to 10,000 | 1 ms | 0 | All | Immediately | Setup | *1 | | | | | | | | | | | | |
| Pn30C | 2 | Speed Feedforward Average Movement Time | 0 to 5,100 | 0.1 ms | 0 | All | Immediately | Setup | *1 | | | | | | | | | | | | |
| Pn310 | 2 | Vibration Detection Selections | 0000h to 0002h | - | 0000h | All | Immediately | Setup | *1 | | | | | | | | | | | | |
| | | <table border="1"> <thead> <tr> <th colspan="2">Vibration Detection Selection</th> </tr> </thead> <tbody> <tr> <td>n.□□□X</td> <td>0</td> <td>Do not detect vibration.</td> </tr> <tr> <td>n.□□□X</td> <td>1</td> <td>Output a warning (A.911) if vibration is detected.</td> </tr> <tr> <td>n.□□□X</td> <td>2</td> <td>Output an alarm (A.520) if vibration is detected.</td> </tr> </tbody> </table> | | | | | | | | | Vibration Detection Selection | | n.□□□X | 0 | Do not detect vibration. | n.□□□X | 1 | Output a warning (A.911) if vibration is detected. | n.□□□X | 2 | Output an alarm (A.520) if vibration is detected. |
| | | Vibration Detection Selection | | | | | | | | | | | | | | | | | | | |
| | | n.□□□X | 0 | Do not detect vibration. | | | | | | | | | | | | | | | | | |
| | | n.□□□X | 1 | Output a warning (A.911) if vibration is detected. | | | | | | | | | | | | | | | | | |
| | | n.□□□X | 2 | Output an alarm (A.520) if vibration is detected. | | | | | | | | | | | | | | | | | |
| n.□□X□ | Reserved parameter (Do not change.) | | | | | | | | | | | | | | | | | | | | |
| n.□X□□ | Reserved parameter (Do not change.) | | | | | | | | | | | | | | | | | | | | |
| n.X□□□ | Reserved parameter (Do not change.) | | | | | | | | | | | | | | | | | | | | |
| Pn311 | 2 | Vibration Detection Sensitivity | 50 to 500 | 1% | 100 | All | Immediately | Tuning | *1 | | | | | | | | | | | | |
| Pn312 | 2 | Vibration Detection Level | 0 to 5,000 | 1 min ⁻¹ | 50 | Rotary | Immediately | Tuning | *1 | | | | | | | | | | | | |
| Pn316 | 2 | Maximum Motor Speed | 0 to 65,535 | 1 min ⁻¹ | 10000 | Rotary | After restart | Setup | *1 | | | | | | | | | | | | |
| Pn324 | 2 | Moment of Inertia Calculation Starting Level | 0 to 20,000 | 1% | 300 | All | Immediately | Setup | *1 | | | | | | | | | | | | |
| Pn380 | 2 | Internal Set Speed 1 | 0 to 10,000 | 1 mm/s | 10 | Linear | Immediately | Setup | *1 | | | | | | | | | | | | |
| Pn381 | 2 | Internal Set Speed 2 | 0 to 10,000 | 1 mm/s | 20 | Linear | Immediately | Setup | *1 | | | | | | | | | | | | |
| Pn382 | 2 | Internal Set Speed 3 | 0 to 10,000 | 1 mm/s | 30 | Linear | Immediately | Setup | *1 | | | | | | | | | | | | |
| Pn383 | 2 | Jogging Speed | 0 to 10,000 | 1 mm/s | 50 | Linear | Immediately | Setup | *1 | | | | | | | | | | | | |
| Pn384 | 2 | Vibration Detection Level | 0 to 5,000 | 1 mm/s | 10 | Linear | Immediately | Tuning | *1 | | | | | | | | | | | | |
| Pn385 | 2 | Maximum Motor Speed | 1 to 100 | 100 mm/s | 50 | Linear | After restart | Setup | *1 | | | | | | | | | | | | |
| Pn400 | 2 | Torque Reference Input Gain | 10 to 100 | 0.1 V/ rated torque | 30 | All | Immediately | Setup | *1 | | | | | | | | | | | | |
| Pn401 | 2 | First Stage First Torque Reference Filter Time Constant | 0 to 65,535 | 0.01 ms | 100 | All | Immediately | Tuning | *1 | | | | | | | | | | | | |
| Pn402 | 2 | Forward Torque Limit | 0 to 800 | 1%*2 | 800 | Rotary | Immediately | Setup | *1 | | | | | | | | | | | | |
| Pn403 | 2 | Reverse Torque Limit | 0 to 800 | 1%*2 | 800 | Rotary | Immediately | Setup | *1 | | | | | | | | | | | | |
| Pn404 | 2 | Forward External Torque Limit | 0 to 800 | 1%*2 | 100 | All | Immediately | Setup | *1 | | | | | | | | | | | | |
| Pn405 | 2 | Reverse External Torque Limit | 0 to 800 | 1%*2 | 100 | All | Immediately | Setup | *1 | | | | | | | | | | | | |
| Pn406 | 2 | Emergency Stop Torque | 0 to 800 | 1%*2 | 800 | All | Immediately | Setup | *1 | | | | | | | | | | | | |
| Pn407 | 2 | Speed Limit during Torque Control | 0 to 10,000 | 1 min ⁻¹ | 10000 | Rotary | Immediately | Setup | *1 | | | | | | | | | | | | |

Continued on next page.

5.1 SERVOPACKs with Analog Voltage/Pulse Train References

5.1.2 List of Parameters

Continued from previous page.

| Parameter No. | Size | Name | Setting Range | Setting Unit | Default Setting | Applicable Motors | When Enabled | Classification | Reference | |
|---------------|--------|--|---|---|-----------------|-------------------|--------------|----------------|---------------------|--|
| Pn408 | 2 | Torque-Related Function Selections | 0000h to 1111h | - | 0000h | All | - | Setup | *1 | |
| | | | Notch Filter Selection 1 | | | | | | When Enabled | |
| | n.□□□X | | 0 | Disable first stage notch filter. | | | | | Immediately | |
| | | | 1 | Enable first stage notch filter. | | | | | | |
| | | | Speed Limit Selection | | | | | | When Enabled | |
| | n.□□X□ | | 0 | Use the smaller of the maximum motor speed and the setting of Pn407 as the speed limit. | | | | | After restart | |
| | | | | Use the smaller of the maximum motor speed and the setting of Pn480 as the speed limit. | | | | | | |
| | | | 1 | Use the smaller of the overspeed alarm detection speed and the setting of Pn407 as the speed limit. | | | | | | |
| | | | | Use the smaller of the overspeed alarm detection speed and the setting of Pn480 as the speed limit. | | | | | | |
| | | | Notch Filter Selection 2 | | | | | | When Enabled | |
| | n.□X□□ | | 0 | Disable second stage notch filter. | | | | | Immediately | |
| | | | 1 | Enable second stage notch filter. | | | | | | |
| | | | Friction Compensation Function Selection | | | | | | When Enabled | |
| | n.X□□□ | | 0 | Disable friction compensation. | | | | | Immediately | |
| | | | 1 | Enable friction compensation. | | | | | | |
| Pn409 | 2 | First Stage Notch Filter Frequency | 50 to 5,000 | 1 Hz | 5000 | All | Immediately | Tuning | *1 | |
| Pn40A | 2 | First Stage Notch Filter Q Value | 50 to 1,000 | 0.01 | 70 | All | Immediately | Tuning | *1 | |
| Pn40B | 2 | First Stage Notch Filter Depth | 0 to 1,000 | 0.001 | 0 | All | Immediately | Tuning | *1 | |
| Pn40C | 2 | Second Stage Notch Filter Frequency | 50 to 5,000 | 1 Hz | 5000 | All | Immediately | Tuning | *1 | |
| Pn40D | 2 | Second Stage Notch Filter Q Value | 50 to 1,000 | 0.01 | 70 | All | Immediately | Tuning | *1 | |
| Pn40E | 2 | Second Stage Notch Filter Depth | 0 to 1,000 | 0.001 | 0 | All | Immediately | Tuning | *1 | |
| Pn40F | 2 | Second Stage Second Torque Reference Filter Frequency | 100 to 5,000 | 1 Hz | 5000 | All | Immediately | Tuning | *1 | |
| Pn410 | 2 | Second Stage Second Torque Reference Filter Q Value | 50 to 100 | 0.01 | 50 | All | Immediately | Tuning | *1 | |
| Pn412 | 2 | First Stage Second Torque Reference Filter Time Constant | 0 to 65,535 | 0.01 ms | 100 | All | Immediately | Tuning | *1 | |
| Pn415 | 2 | T-REF Filter Time Constant | 0 to 65,535 | 0.01 ms | 0 | All | Immediately | Setup | *1 | |

Continued on next page.

Continued from previous page.

| Parameter No. | Size | Name | Setting Range | Setting Unit | Default Setting | Applicable Motors | When Enabled | Classification | Reference |
|---------------|--|---|------------------------------------|--------------|-----------------|-------------------|--------------|---------------------|---------------|
| Pn416 | 2 | Torque-Related Function Selections 2 | 0000h to 1111h | - | 0000h | All | Immediately | Setup | *1 |
| | n.□□□X | Notch Filter Selection 3 | | | | | | | |
| | | 0 | Disable third stage notch filter. | | | | | | |
| | n.□□X□ | Notch Filter Selection 4 | | | | | | | |
| | | 0 | Disable fourth stage notch filter. | | | | | | |
| | n.□X□□ | Notch Filter Selection 5 | | | | | | | |
| | | 0 | Disable fifth stage notch filter. | | | | | | |
| | n.X□□□ | Reserved parameter (Do not change.) | | | | | | | |
| | | | | | | | | | |
| | Pn417 | 2 | Third Stage Notch Filter Frequency | 50 to 5,000 | 1 Hz | 5000 | All | Immediately | Tuning |
| Pn418 | 2 | Third Stage Notch Filter Q Value | 50 to 1,000 | 0.01 | 70 | All | Immediately | Tuning | *1 |
| Pn419 | 2 | Third Stage Notch Filter Depth | 0 to 1,000 | 0.001 | 0 | All | Immediately | Tuning | *1 |
| Pn41A | 2 | Fourth Stage Notch Filter Frequency | 50 to 5,000 | 1 Hz | 5000 | All | Immediately | Tuning | *1 |
| Pn41B | 2 | Fourth Stage Notch Filter Q Value | 50 to 1,000 | 0.01 | 70 | All | Immediately | Tuning | *1 |
| Pn41C | 2 | Fourth Stage Notch Filter Depth | 0 to 1,000 | 0.001 | 0 | All | Immediately | Tuning | *1 |
| Pn41D | 2 | Fifth Stage Notch Filter Frequency | 50 to 5,000 | 1 Hz | 5000 | All | Immediately | Tuning | *1 |
| Pn41E | 2 | Fifth Stage Notch Filter Q Value | 50 to 1,000 | 0.01 | 70 | All | Immediately | Tuning | *1 |
| Pn41F | 2 | Fifth Stage Notch Filter Depth | 0 to 1,000 | 0.001 | 0 | All | Immediately | Tuning | *1 |
| Pn423 | 2 | Speed Ripple Compensation Selections | 0000h to 1111h | - | 0000h | Rotary | - | Setup | *1 |
| | n.□□□X | Speed Ripple Compensation Function Selection | | | | | | When Enabled | |
| | | 0 | Disable speed ripple compensation. | | | | | | Immediately |
| | 1 | Enable speed ripple compensation. | | | | | | | |
| | n.□□X□ | Speed Ripple Compensation Information Disagreement Warning Detection Selection | | | | | | When Enabled | |
| | | 0 | Detect A.942 alarms. | | | | | | After restart |
| | 1 | Do not detect A.942 alarms. | | | | | | | |
| | n.□X□□ | Speed Ripple Compensation Enable Condition Selection | | | | | | When Enabled | |
| | | 0 | Speed reference | | | | | | After restart |
| | 1 | Motor speed | | | | | | | |
| n.X□□□ | Reserved parameter (Do not change.) | | | | | | | | |
| | | | | | | | | | |
| Pn424 | 2 | Torque Limit at Main Circuit Voltage Drop | 0 to 100 | 1%*2 | 50 | All | Immediately | Setup | *1 |

Continued on next page.

5.1 SERVOPACKs with Analog Voltage/Pulse Train References

5.1.2 List of Parameters

Continued from previous page.

| Parameter No. | Size | Name | Setting Range | Setting Unit | Default Setting | Applicable Motors | When Enabled | Classification | Reference | | |
|---------------|-------------------------------------|--|-------------------------------------|---|-----------------|-------------------|---------------|----------------|-----------|--|--|
| Pn425 | 2 | Release Time for Torque Limit at Main Circuit Voltage Drop | 0 to 1,000 | 1 ms | 100 | All | Immediately | Setup | *1 | | |
| Pn426 | 2 | Torque Feedforward Average Movement Time | 0 to 5,100 | 0.1 ms | 0 | All | Immediately | Setup | *1 | | |
| Pn427 | 2 | Speed Ripple Compensation Enable Speed | 0 to 10,000 | 1 min ⁻¹ | 0 | Rotary Servomotor | Immediately | Tuning | *1 | | |
| Pn456 | 2 | Sweep Torque Reference Amplitude | 1 to 800 | 1% | 15 | All | Immediately | Tuning | *1 | | |
| Pn460 | 2 | Notch Filter Adjustment Selections 1 | 0000h to 0101h | – | 0101h | All | Immediately | Tuning | *1 | | |
| | | Notch Filter Adjustment Selection 1 | | | | | | | | | |
| | | n.□□□X | 0 | Do not adjust the first stage notch filter automatically during execution of autotuning without a host reference, autotuning with a host reference, and custom tuning. | | | | | | | |
| | | n.□□□X | 1 | Adjust the first stage notch filter automatically during execution of autotuning without a host reference, autotuning with a host reference, and custom tuning. | | | | | | | |
| | | n.□□X□ | Reserved parameter (Do not change.) | | | | | | | | |
| | | Notch Filter Adjustment Selection 2 | | | | | | | | | |
| | | n.□X□□ | 0 | Do not adjust the second stage notch filter automatically when the tuning-less function is enabled or during execution of autotuning without a host reference, autotuning with a host reference, and custom tuning. | | | | | | | |
| n.□X□□ | 1 | Adjust the second stage notch filter automatically when the tuning-less function is enabled or during execution of autotuning without a host reference, autotuning with a host reference, and custom tuning. | | | | | | | | | |
| n.X□□□ | Reserved parameter (Do not change.) | | | | | | | | | | |
| Pn475 | 2 | Gravity Compensation-Related Selections | 0000h to 0001h | – | 0000h | All | After restart | Setup | *1 | | |
| | | Gravity Compensation Selection | | | | | | | | | |
| | | n.□□□X | 0 | Disable gravity compensation. | | | | | | | |
| | | n.□□□X | 1 | Enable gravity compensation. | | | | | | | |
| | | n.□□X□ | Reserved parameter (Do not change.) | | | | | | | | |
| | | n.□X□□ | Reserved parameter (Do not change.) | | | | | | | | |
| | | n.X□□□ | Reserved parameter (Do not change.) | | | | | | | | |
| Pn476 | 2 | Gravity Compensation Torque | -1,000 to 1,000 | 0.1% | 0 | All | Immediately | Tuning | *1 | | |
| Pn480 | 2 | Speed Limit during Force Control | 0 to 10,000 | 1 mm/s | 10000 | Linear | Immediately | Setup | *1 | | |
| Pn481 | 2 | Polarity Detection Speed Loop Gain | 10 to 20,000 | 0.1 Hz | 400 | Linear | Immediately | Tuning | – | | |
| Pn482 | 2 | Polarity Detection Speed Loop Integral Time Constant | 15 to 51,200 | 0.01 ms | 3000 | Linear | Immediately | Tuning | – | | |
| Pn483 | 2 | Forward Force Limit | 0 to 800 | 1%*2 | 30 | Linear | Immediately | Setup | *1 | | |
| Pn484 | 2 | Reverse Force Limit | 0 to 800 | 1%*2 | 30 | Linear | Immediately | Setup | *1 | | |
| Pn485 | 2 | Polarity Detection Reference Speed | 0 to 100 | 1 mm/s | 20 | Linear | Immediately | Tuning | – | | |
| Pn486 | 2 | Polarity Detection Reference Acceleration/Deceleration Time | 0 to 100 | 1 ms | 25 | Linear | Immediately | Tuning | – | | |

Continued on next page.

Continued from previous page.

| Parameter No. | Size | Name | Setting Range | Setting Unit | Default Setting | Applicable Motors | When Enabled | Classification | Reference |
|---------------|------|---|---------------|---------------------|-----------------|-------------------|--------------|----------------|-----------|
| Pn487 | 2 | Polarity Detection Constant Speed Time | 0 to 300 | 1 ms | 0 | Linear | Immediately | Tuning | – |
| Pn488 | 2 | Polarity Detection Reference Waiting Time | 50 to 500 | 1 ms | 100 | Linear | Immediately | Tuning | – |
| Pn48E | 2 | Polarity Detection Range | 1 to 65,535 | 1 mm | 10 | Linear | Immediately | Tuning | – |
| Pn490 | 2 | Polarity Detection Load Level | 0 to 20,000 | 1% | 100 | Linear | Immediately | Tuning | – |
| Pn495 | 2 | Polarity Detection Confirmation Force Reference | 0 to 200 | 1% | 100 | Linear | Immediately | Tuning | – |
| Pn498 | 2 | Polarity Detection Allowable Error Range | 0 to 30 | 1 deg | 10 | Linear | Immediately | Tuning | – |
| Pn49F | 2 | Speed Ripple Compensation Enable Speed | 0 to 10,000 | 1 mm/s | 0 | Linear | Immediately | Tuning | *1 |
| Pn501 | 2 | Zero Clamping Level | 0 to 10,000 | 1 min ⁻¹ | 10 | Rotary | Immediately | Setup | *1 |
| Pn502 | 2 | Rotation Detection Level | 1 to 10,000 | 1 min ⁻¹ | 20 | Rotary | Immediately | Setup | *1 |
| Pn503 | 2 | Speed Coincidence Detection Signal Output Width | 0 to 100 | 1 min ⁻¹ | 10 | Rotary | Immediately | Setup | *1 |
| Pn506 | 2 | Brake Reference-Servo OFF Delay Time | 0 to 50 | 10 ms | 0 | All | Immediately | Setup | *1 |
| Pn507 | 2 | Brake Reference Output Speed Level | 0 to 10,000 | 1 min ⁻¹ | 100 | Rotary | Immediately | Setup | *1 |
| Pn508 | 2 | Servo OFF-Brake Command Waiting Time | 10 to 100 | 10 ms | 50 | All | Immediately | Setup | *1 |
| Pn509 | 2 | Momentary Power Interruption Hold Time | 20 to 50,000 | 1 ms | 20 | All | Immediately | Setup | *1 |

Continued on next page.

5.1 SERVOPACKs with Analog Voltage/Pulse Train References

5.1.2 List of Parameters

Continued from previous page.

| Parameter No. | Size | Name | Setting Range | Setting Unit | Default Setting | Applicable Motors | When Enabled | Classification | Reference | |
|---------------|--------|------------------------------|--|--|-----------------|-------------------|---------------|----------------|-----------|--|
| Pn50A | 2 | Input Signal Selections 1 | 0000h to FFF2h | - | 2100h | All | After restart | Setup | *1 | |
| | n.□□□X | | Input Signal Allocation Mode | | | | | | | |
| | | | 0 | Use the sequence input signal terminals with the default allocations. | | | | | | |
| | | | 1 | Change the sequence input signal allocations. | | | | | | |
| | | | 2 | Reserved setting (Do not use.) | | | | | | |
| | n.□□X□ | | /S-ON (Servo ON) Signal Allocation | | | | | | | |
| | | | 0 | Active when CN1-40 input signal is ON (closed). | | | | | | |
| | | | 1 | Active when CN1-41 input signal is ON (closed). | | | | | | |
| | | | 2 | Active when CN1-42 input signal is ON (closed). | | | | | | |
| | | | 3 | Active when CN1-43 input signal is ON (closed). | | | | | | |
| | | | 4 | Active when CN1-44 input signal is ON (closed). | | | | | | |
| | | | 5 | Active when CN1-45 input signal is ON (closed). | | | | | | |
| | | | 6 | Active when CN1-46 input signal is ON (closed). | | | | | | |
| | | | 7 | The signal is always active. | | | | | | |
| | | | 8 | The signal is always inactive. | | | | | | |
| | | | 9 | Active when CN1-40 input signal is OFF (open). | | | | | | |
| | | | A | Active when CN1-41 input signal is OFF (open). | | | | | | |
| | | | B | Active when CN1-42 input signal is OFF (open). | | | | | | |
| | | | C | Active when CN1-43 input signal is OFF (open). | | | | | | |
| | | | D | Active when CN1-44 input signal is OFF (open). | | | | | | |
| | | | E | Active when CN1-45 input signal is OFF (open). | | | | | | |
| | | | F | Active when CN1-46 input signal is OFF (open). | | | | | | |
| | n.□X□□ | | /P-CON (Proportional Control) Signal Allocation | | | | | | | |
| | | | 0 to F | The allocations are the same as the /S-ON (Servo ON) signal allocations. | | | | | | |
| | n.X□□□ | | P-OT (Forward Drive Prohibit) Signal Allocation | | | | | | | |
| | | | 0 | Enable forward drive when CN1-40 input signal is ON (closed). | | | | | | |
| | | | 1 | Enable forward drive when CN1-41 input signal is ON (closed). | | | | | | |
| | | | 2 | Enable forward drive when CN1-42 input signal is ON (closed). | | | | | | |
| | | | 3 | Enable forward drive when CN1-43 input signal is ON (closed). | | | | | | |
| | | | 4 | Enable forward drive when CN1-44 input signal is ON (closed). | | | | | | |
| | | | 5 | Enable forward drive when CN1-45 input signal is ON (closed). | | | | | | |
| | | | 6 | Enable forward drive when CN1-46 input signal is ON (closed). | | | | | | |
| | | | 7 | Set the signal to always prohibit forward drive. | | | | | | |
| | | | 8 | Set the signal to always enable forward drive. | | | | | | |
| | | | 9 | Enable forward drive when CN1-40 input signal is OFF (open). | | | | | | |
| | | | A | Enable forward drive when CN1-41 input signal is OFF (open). | | | | | | |
| | | | B | Enable forward drive when CN1-42 input signal is OFF (open). | | | | | | |
| | | | C | Enable forward drive when CN1-43 input signal is OFF (open). | | | | | | |
| | | | D | Enable forward drive when CN1-44 input signal is OFF (open). | | | | | | |
| | | | E | Enable forward drive when CN1-45 input signal is OFF (open). | | | | | | |
| | | | F | Enable forward drive when CN1-46 input signal is OFF (open). | | | | | | |

Continued on next page.

Continued from previous page.

| Parameter No. | Size | Name | Setting Range | Setting Unit | Default Setting | Applicable Motors | When Enabled | Classification | Reference | |
|---------------|--|--|--|--------------|-----------------|-------------------|---------------|----------------|-----------|--|
| Pn50B | 2 | Input Signal Selections ² | 0000h to FFFFh | - | 6543h | All | After restart | Setup | *1 | |
| | N-OT (Reverse Drive Prohibit) Signal Allocation | | | | | | | | | |
| | n.□□□X | 0 | Enable reverse drive when CN1-40 input signal is ON (closed). | | | | | | | |
| | | 1 | Enable reverse drive when CN1-41 input signal is ON (closed). | | | | | | | |
| | | 2 | Enable reverse drive when CN1-42 input signal is ON (closed). | | | | | | | |
| | | 3 | Enable reverse drive when CN1-43 input signal is ON (closed). | | | | | | | |
| | | 4 | Enable reverse drive when CN1-44 input signal is ON (closed). | | | | | | | |
| | | 5 | Enable reverse drive when CN1-45 input signal is ON (closed). | | | | | | | |
| | | 6 | Enable reverse drive when CN1-46 input signal is ON (closed). | | | | | | | |
| | | 7 | Set the signal to always prohibit reverse drive. | | | | | | | |
| | | 8 | Set the signal to always enable reverse drive. | | | | | | | |
| | | 9 | Enable reverse drive when CN1-40 input signal is OFF (open). | | | | | | | |
| | | A | Enable reverse drive when CN1-41 input signal is OFF (open). | | | | | | | |
| | | B | Enable reverse drive when CN1-42 input signal is OFF (open). | | | | | | | |
| | | C | Enable reverse drive when CN1-43 input signal is OFF (open). | | | | | | | |
| | | D | Enable reverse drive when CN1-44 input signal is OFF (open). | | | | | | | |
| | | E | Enable reverse drive when CN1-45 input signal is OFF (open). | | | | | | | |
| | | F | Enable reverse drive when CN1-46 input signal is OFF (open). | | | | | | | |
| | /ALM-RST (Alarm Reset) Signal Allocation | | | | | | | | | |
| | n.□□X□ | 0 | Active on signal edge when CN1-40 input signal changes from OFF (open) to ON (closed). | | | | | | | |
| | | 1 | Active on signal edge when CN1-41 input signal changes from OFF (open) to ON (closed). | | | | | | | |
| | | 2 | Active on signal edge when CN1-42 input signal changes from OFF (open) to ON (closed). | | | | | | | |
| | | 3 | Active on signal edge when CN1-43 input signal changes from OFF (open) to ON (closed). | | | | | | | |
| | | 4 | Active on signal edge when CN1-44 input signal changes from OFF (open) to ON (closed). | | | | | | | |
| | | 5 | Active on signal edge when CN1-45 input signal changes from OFF (open) to ON (closed). | | | | | | | |
| | | 6 | Active on signal edge when CN1-46 input signal changes from OFF (open) to ON (closed). | | | | | | | |
| | | 7 | Reserved setting (Do not use.) | | | | | | | |
| | | 8 | The signal is always inactive. | | | | | | | |
| | | 9 | Active on signal edge when CN1-40 input signal changes from ON (closed) to OFF (open). | | | | | | | |
| | | A | Active on signal edge when CN1-41 input signal changes from ON (closed) to OFF (open). | | | | | | | |
| | | B | Active on signal edge when CN1-42 input signal changes from ON (closed) to OFF (open). | | | | | | | |
| | | C | Active on signal edge when CN1-43 input signal changes from ON (closed) to OFF (open). | | | | | | | |
| | | D | Active on signal edge when CN1-44 input signal changes from ON (closed) to OFF (open). | | | | | | | |
| | | E | Active on signal edge when CN1-45 input signal changes from ON (closed) to OFF (open). | | | | | | | |
| | | F | Active on signal edge when CN1-46 input signal changes from ON (closed) to OFF (open). | | | | | | | |
| | n.□X□□ | /P-CL (Forward External Torque Limit Input) Signal Allocation | | | | | | | | |
| | | 0 to F | The allocations are the same as the /S-ON (Servo ON) signal allocations. | | | | | | | |
| | n.X□□□ | /N-CL (Reverse External Torque Limit Input) Signal Allocation | | | | | | | | |
| | | 0 to F | The allocations are the same as the /S-ON (Servo ON) signal allocations. | | | | | | | |

Continued on next page.

5.1 SERVOPACKs with Analog Voltage/Pulse Train References

5.1.2 List of Parameters

Continued from previous page.

| Parameter No. | Size | Name | Setting Range | Setting Unit | Default Setting | Applicable Motors | When Enabled | Classification | Reference | | | | | | | | | | | | | | | | | | | | | | | | | | | | | | | | | | | | | | | | | | | | | | |
|---------------|---|--|----------------|--------------|-----------------|-------------------|---------------|----------------|-----------|--|--|---|---|---|---|---|---|---|---|---|---|---|---|---|---|--------|--------------------------------|--|----------------------------------|--|--|---|--|---|--|---|--|---|--|---|--|---|--|---|--|--------|---|---|--|--------|---|--|--|--------|---|
| Pn50C | 2 | Input Signal Selections | 0000h to FFFFh | - | 8888h | All | After restart | Setup | *1 | | | | | | | | | | | | | | | | | | | | | | | | | | | | | | | | | | | | | | | | | | | | | | |
| | 3 | <table border="1"> <thead> <tr> <th colspan="2">/SPD-D (Motor Direction) Signal Allocation</th> </tr> </thead> <tbody> <tr><td>0</td><td>Active when CN1-40 input signal is ON (closed).</td></tr> <tr><td>1</td><td>Active when CN1-41 input signal is ON (closed).</td></tr> <tr><td>2</td><td>Active when CN1-42 input signal is ON (closed).</td></tr> <tr><td>3</td><td>Active when CN1-43 input signal is ON (closed).</td></tr> <tr><td>4</td><td>Active when CN1-44 input signal is ON (closed).</td></tr> <tr><td>5</td><td>Active when CN1-45 input signal is ON (closed).</td></tr> <tr><td>6</td><td>Active when CN1-46 input signal is ON (closed).</td></tr> <tr><td>n.□□□X</td><td>7 The signal is always active.</td></tr> <tr><td></td><td>8 The signal is always inactive.</td></tr> <tr><td></td><td>9 Active when CN1-40 input signal is OFF (open).</td></tr> <tr><td>A</td><td>Active when CN1-41 input signal is OFF (open).</td></tr> <tr><td>B</td><td>Active when CN1-42 input signal is OFF (open).</td></tr> <tr><td>C</td><td>Active when CN1-43 input signal is OFF (open).</td></tr> <tr><td>D</td><td>Active when CN1-44 input signal is OFF (open).</td></tr> <tr><td>E</td><td>Active when CN1-45 input signal is OFF (open).</td></tr> <tr><td>F</td><td>Active when CN1-46 input signal is OFF (open).</td></tr> </tbody> </table> <table border="1"> <thead> <tr> <th colspan="2">/SPD-A (Internal Set Speed Selection Input) Signal Allocation</th> </tr> </thead> <tbody> <tr> <td>n.□□X□</td> <td>0 to F The allocations are the same as the /SPD-D (Motor Direction) signal allocations.</td> </tr> </tbody> </table> <table border="1"> <thead> <tr> <th colspan="2">/SPD-B (Internal Set Speed Selection Input) Signal Allocation</th> </tr> </thead> <tbody> <tr> <td>n.□X□□</td> <td>0 to F The allocations are the same as the /SPD-D (Motor Direction) signal allocations.</td> </tr> </tbody> </table> <table border="1"> <thead> <tr> <th colspan="2">/C-SEL (Control Selection Input) Signal Allocation</th> </tr> </thead> <tbody> <tr> <td>n.X□□□</td> <td>0 to F The allocations are the same as the /SPD-D (Motor Direction) signal allocations.</td> </tr> </tbody> </table> | | | | | | | | /SPD-D (Motor Direction) Signal Allocation | | 0 | Active when CN1-40 input signal is ON (closed). | 1 | Active when CN1-41 input signal is ON (closed). | 2 | Active when CN1-42 input signal is ON (closed). | 3 | Active when CN1-43 input signal is ON (closed). | 4 | Active when CN1-44 input signal is ON (closed). | 5 | Active when CN1-45 input signal is ON (closed). | 6 | Active when CN1-46 input signal is ON (closed). | n.□□□X | 7 The signal is always active. | | 8 The signal is always inactive. | | 9 Active when CN1-40 input signal is OFF (open). | A | Active when CN1-41 input signal is OFF (open). | B | Active when CN1-42 input signal is OFF (open). | C | Active when CN1-43 input signal is OFF (open). | D | Active when CN1-44 input signal is OFF (open). | E | Active when CN1-45 input signal is OFF (open). | F | Active when CN1-46 input signal is OFF (open). | /SPD-A (Internal Set Speed Selection Input) Signal Allocation | | n.□□X□ | 0 to F The allocations are the same as the /SPD-D (Motor Direction) signal allocations. | /SPD-B (Internal Set Speed Selection Input) Signal Allocation | | n.□X□□ | 0 to F The allocations are the same as the /SPD-D (Motor Direction) signal allocations. | /C-SEL (Control Selection Input) Signal Allocation | | n.X□□□ | 0 to F The allocations are the same as the /SPD-D (Motor Direction) signal allocations. |
| | /SPD-D (Motor Direction) Signal Allocation | | | | | | | | | | | | | | | | | | | | | | | | | | | | | | | | | | | | | | | | | | | | | | | | | | | | | | |
| | 0 | Active when CN1-40 input signal is ON (closed). | | | | | | | | | | | | | | | | | | | | | | | | | | | | | | | | | | | | | | | | | | | | | | | | | | | | | |
| | 1 | Active when CN1-41 input signal is ON (closed). | | | | | | | | | | | | | | | | | | | | | | | | | | | | | | | | | | | | | | | | | | | | | | | | | | | | | |
| | 2 | Active when CN1-42 input signal is ON (closed). | | | | | | | | | | | | | | | | | | | | | | | | | | | | | | | | | | | | | | | | | | | | | | | | | | | | | |
| | 3 | Active when CN1-43 input signal is ON (closed). | | | | | | | | | | | | | | | | | | | | | | | | | | | | | | | | | | | | | | | | | | | | | | | | | | | | | |
| | 4 | Active when CN1-44 input signal is ON (closed). | | | | | | | | | | | | | | | | | | | | | | | | | | | | | | | | | | | | | | | | | | | | | | | | | | | | | |
| | 5 | Active when CN1-45 input signal is ON (closed). | | | | | | | | | | | | | | | | | | | | | | | | | | | | | | | | | | | | | | | | | | | | | | | | | | | | | |
| | 6 | Active when CN1-46 input signal is ON (closed). | | | | | | | | | | | | | | | | | | | | | | | | | | | | | | | | | | | | | | | | | | | | | | | | | | | | | |
| | n.□□□X | 7 The signal is always active. | | | | | | | | | | | | | | | | | | | | | | | | | | | | | | | | | | | | | | | | | | | | | | | | | | | | | |
| | | 8 The signal is always inactive. | | | | | | | | | | | | | | | | | | | | | | | | | | | | | | | | | | | | | | | | | | | | | | | | | | | | | |
| | | 9 Active when CN1-40 input signal is OFF (open). | | | | | | | | | | | | | | | | | | | | | | | | | | | | | | | | | | | | | | | | | | | | | | | | | | | | | |
| | A | Active when CN1-41 input signal is OFF (open). | | | | | | | | | | | | | | | | | | | | | | | | | | | | | | | | | | | | | | | | | | | | | | | | | | | | | |
| | B | Active when CN1-42 input signal is OFF (open). | | | | | | | | | | | | | | | | | | | | | | | | | | | | | | | | | | | | | | | | | | | | | | | | | | | | | |
| | C | Active when CN1-43 input signal is OFF (open). | | | | | | | | | | | | | | | | | | | | | | | | | | | | | | | | | | | | | | | | | | | | | | | | | | | | | |
| | D | Active when CN1-44 input signal is OFF (open). | | | | | | | | | | | | | | | | | | | | | | | | | | | | | | | | | | | | | | | | | | | | | | | | | | | | | |
| | E | Active when CN1-45 input signal is OFF (open). | | | | | | | | | | | | | | | | | | | | | | | | | | | | | | | | | | | | | | | | | | | | | | | | | | | | | |
| | F | Active when CN1-46 input signal is OFF (open). | | | | | | | | | | | | | | | | | | | | | | | | | | | | | | | | | | | | | | | | | | | | | | | | | | | | | |
| | /SPD-A (Internal Set Speed Selection Input) Signal Allocation | | | | | | | | | | | | | | | | | | | | | | | | | | | | | | | | | | | | | | | | | | | | | | | | | | | | | | |
| | n.□□X□ | 0 to F The allocations are the same as the /SPD-D (Motor Direction) signal allocations. | | | | | | | | | | | | | | | | | | | | | | | | | | | | | | | | | | | | | | | | | | | | | | | | | | | | | |
| | /SPD-B (Internal Set Speed Selection Input) Signal Allocation | | | | | | | | | | | | | | | | | | | | | | | | | | | | | | | | | | | | | | | | | | | | | | | | | | | | | | |
| | n.□X□□ | 0 to F The allocations are the same as the /SPD-D (Motor Direction) signal allocations. | | | | | | | | | | | | | | | | | | | | | | | | | | | | | | | | | | | | | | | | | | | | | | | | | | | | | |
| | /C-SEL (Control Selection Input) Signal Allocation | | | | | | | | | | | | | | | | | | | | | | | | | | | | | | | | | | | | | | | | | | | | | | | | | | | | | | |
| | n.X□□□ | 0 to F The allocations are the same as the /SPD-D (Motor Direction) signal allocations. | | | | | | | | | | | | | | | | | | | | | | | | | | | | | | | | | | | | | | | | | | | | | | | | | | | | | |

Continued on next page.

Continued from previous page.

| Parameter No. | Size | Name | Setting Range | Setting Unit | Default Setting | Applicable Motors | When Enabled | Classification | Reference | | | | | | | | | | | | | | | | | | | | | | | | | | | | | | | | | | | | | | | | | | | | | | | | | | | |
|---|--|---|--|--------------|-----------------|-------------------|---------------|----------------|---|--|-------------------|-------------------|--------|---|---|-----|---|---|--|---|---|--|---|---|--|---|---|--|---|---|--|---|---|--|---|------------------------------|--|---|--------------------------------|--|---|--|--|---|--|--|---|--|--|---|--|--|---|--|--|---|--|--|---|--|
| Pn50D | 2 | Input Signal Selections | 0000h to FFFFh | – | 8888h | – | After restart | Setup | *1 | | | | | | | | | | | | | | | | | | | | | | | | | | | | | | | | | | | | | | | | | | | | | | | | | | | |
| | | <table border="1"> <thead> <tr> <th colspan="2">/ZCLAMP (Zero Clamping Input) Signal Allocation</th> <th>Applicable Motors</th> </tr> </thead> <tbody> <tr> <td>n.□□□X</td> <td>0</td> <td>Active when CN1-40 input signal is ON (closed).</td> <td rowspan="16">All</td> </tr> <tr> <td></td> <td>1</td> <td>Active when CN1-41 input signal is ON (closed).</td> </tr> <tr> <td></td> <td>2</td> <td>Active when CN1-42 input signal is ON (closed).</td> </tr> <tr> <td></td> <td>3</td> <td>Active when CN1-43 input signal is ON (closed).</td> </tr> <tr> <td></td> <td>4</td> <td>Active when CN1-44 input signal is ON (closed).</td> </tr> <tr> <td></td> <td>5</td> <td>Active when CN1-45 input signal is ON (closed).</td> </tr> <tr> <td></td> <td>6</td> <td>Active when CN1-46 input signal is ON (closed).</td> </tr> <tr> <td></td> <td>7</td> <td>The signal is always active.</td> </tr> <tr> <td></td> <td>8</td> <td>The signal is always inactive.</td> </tr> <tr> <td></td> <td>9</td> <td>Active when CN1-40 input signal is OFF (open).</td> </tr> <tr> <td></td> <td>A</td> <td>Active when CN1-41 input signal is OFF (open).</td> </tr> <tr> <td></td> <td>B</td> <td>Active when CN1-42 input signal is OFF (open).</td> </tr> <tr> <td></td> <td>C</td> <td>Active when CN1-43 input signal is OFF (open).</td> </tr> <tr> <td></td> <td>D</td> <td>Active when CN1-44 input signal is OFF (open).</td> </tr> <tr> <td></td> <td>E</td> <td>Active when CN1-45 input signal is OFF (open).</td> </tr> <tr> <td></td> <td>F</td> <td>Active when CN1-46 input signal is OFF (open).</td> </tr> </tbody> </table> | | | | | | | /ZCLAMP (Zero Clamping Input) Signal Allocation | | Applicable Motors | n.□□□X | 0 | Active when CN1-40 input signal is ON (closed). | All | | 1 | Active when CN1-41 input signal is ON (closed). | | 2 | Active when CN1-42 input signal is ON (closed). | | 3 | Active when CN1-43 input signal is ON (closed). | | 4 | Active when CN1-44 input signal is ON (closed). | | 5 | Active when CN1-45 input signal is ON (closed). | | 6 | Active when CN1-46 input signal is ON (closed). | | 7 | The signal is always active. | | 8 | The signal is always inactive. | | 9 | Active when CN1-40 input signal is OFF (open). | | A | Active when CN1-41 input signal is OFF (open). | | B | Active when CN1-42 input signal is OFF (open). | | C | Active when CN1-43 input signal is OFF (open). | | D | Active when CN1-44 input signal is OFF (open). | | E | Active when CN1-45 input signal is OFF (open). | | F | Active when CN1-46 input signal is OFF (open). |
| | /ZCLAMP (Zero Clamping Input) Signal Allocation | | Applicable Motors | | | | | | | | | | | | | | | | | | | | | | | | | | | | | | | | | | | | | | | | | | | | | | | | | | | | | | | | | |
| | n.□□□X | 0 | Active when CN1-40 input signal is ON (closed). | All | | | | | | | | | | | | | | | | | | | | | | | | | | | | | | | | | | | | | | | | | | | | | | | | | | | | | | | | |
| | | 1 | Active when CN1-41 input signal is ON (closed). | | | | | | | | | | | | | | | | | | | | | | | | | | | | | | | | | | | | | | | | | | | | | | | | | | | | | | | | | |
| | | 2 | Active when CN1-42 input signal is ON (closed). | | | | | | | | | | | | | | | | | | | | | | | | | | | | | | | | | | | | | | | | | | | | | | | | | | | | | | | | | |
| | | 3 | Active when CN1-43 input signal is ON (closed). | | | | | | | | | | | | | | | | | | | | | | | | | | | | | | | | | | | | | | | | | | | | | | | | | | | | | | | | | |
| | | 4 | Active when CN1-44 input signal is ON (closed). | | | | | | | | | | | | | | | | | | | | | | | | | | | | | | | | | | | | | | | | | | | | | | | | | | | | | | | | | |
| | | 5 | Active when CN1-45 input signal is ON (closed). | | | | | | | | | | | | | | | | | | | | | | | | | | | | | | | | | | | | | | | | | | | | | | | | | | | | | | | | | |
| | | 6 | Active when CN1-46 input signal is ON (closed). | | | | | | | | | | | | | | | | | | | | | | | | | | | | | | | | | | | | | | | | | | | | | | | | | | | | | | | | | |
| | | 7 | The signal is always active. | | | | | | | | | | | | | | | | | | | | | | | | | | | | | | | | | | | | | | | | | | | | | | | | | | | | | | | | | |
| | | 8 | The signal is always inactive. | | | | | | | | | | | | | | | | | | | | | | | | | | | | | | | | | | | | | | | | | | | | | | | | | | | | | | | | | |
| | | 9 | Active when CN1-40 input signal is OFF (open). | | | | | | | | | | | | | | | | | | | | | | | | | | | | | | | | | | | | | | | | | | | | | | | | | | | | | | | | | |
| | | A | Active when CN1-41 input signal is OFF (open). | | | | | | | | | | | | | | | | | | | | | | | | | | | | | | | | | | | | | | | | | | | | | | | | | | | | | | | | | |
| | | B | Active when CN1-42 input signal is OFF (open). | | | | | | | | | | | | | | | | | | | | | | | | | | | | | | | | | | | | | | | | | | | | | | | | | | | | | | | | | |
| | | C | Active when CN1-43 input signal is OFF (open). | | | | | | | | | | | | | | | | | | | | | | | | | | | | | | | | | | | | | | | | | | | | | | | | | | | | | | | | | |
| | | D | Active when CN1-44 input signal is OFF (open). | | | | | | | | | | | | | | | | | | | | | | | | | | | | | | | | | | | | | | | | | | | | | | | | | | | | | | | | | |
| | | E | Active when CN1-45 input signal is OFF (open). | | | | | | | | | | | | | | | | | | | | | | | | | | | | | | | | | | | | | | | | | | | | | | | | | | | | | | | | | |
| | | F | Active when CN1-46 input signal is OFF (open). | | | | | | | | | | | | | | | | | | | | | | | | | | | | | | | | | | | | | | | | | | | | | | | | | | | | | | | | | |
| | | | <table border="1"> <thead> <tr> <th colspan="2">/INHIBIT (Reference Pulse Inhibit Input) Signal Allocation</th> <th>Applicable Motors</th> </tr> </thead> <tbody> <tr> <td>n.□□X□</td> <td>0 to F</td> <td>The allocations are the same as the /ZCLAMP (Zero Clamping Input) signal allocations.</td> <td>All</td> </tr> </tbody> </table> | | | | | | | /INHIBIT (Reference Pulse Inhibit Input) Signal Allocation | | Applicable Motors | n.□□X□ | 0 to F | The allocations are the same as the /ZCLAMP (Zero Clamping Input) signal allocations. | All | | | | | | | | | | | | | | | | | | | | | | | | | | | | | | | | | | | | | | | | | | | | |
| | /INHIBIT (Reference Pulse Inhibit Input) Signal Allocation | | Applicable Motors | | | | | | | | | | | | | | | | | | | | | | | | | | | | | | | | | | | | | | | | | | | | | | | | | | | | | | | | | |
| | n.□□X□ | 0 to F | The allocations are the same as the /ZCLAMP (Zero Clamping Input) signal allocations. | All | | | | | | | | | | | | | | | | | | | | | | | | | | | | | | | | | | | | | | | | | | | | | | | | | | | | | | | | |
| | | | <table border="1"> <thead> <tr> <th colspan="2">/G-SEL (Gain Selection Input) Signal Allocation</th> <th>Applicable Motors</th> </tr> </thead> <tbody> <tr> <td>n.□X□□</td> <td>0 to F</td> <td>The allocations are the same as the /ZCLAMP (Zero Clamping Input) signal allocations.</td> <td>All</td> </tr> </tbody> </table> | | | | | | | /G-SEL (Gain Selection Input) Signal Allocation | | Applicable Motors | n.□X□□ | 0 to F | The allocations are the same as the /ZCLAMP (Zero Clamping Input) signal allocations. | All | | | | | | | | | | | | | | | | | | | | | | | | | | | | | | | | | | | | | | | | | | | | |
| | /G-SEL (Gain Selection Input) Signal Allocation | | Applicable Motors | | | | | | | | | | | | | | | | | | | | | | | | | | | | | | | | | | | | | | | | | | | | | | | | | | | | | | | | | |
| | n.□X□□ | 0 to F | The allocations are the same as the /ZCLAMP (Zero Clamping Input) signal allocations. | All | | | | | | | | | | | | | | | | | | | | | | | | | | | | | | | | | | | | | | | | | | | | | | | | | | | | | | | | |
| | | <table border="1"> <thead> <tr> <th colspan="2">/P-DET (Polarity Detection Input) Signal Allocation</th> <th>Applicable Motors</th> </tr> </thead> <tbody> <tr> <td>n.X□□□</td> <td>0 to F</td> <td>The allocations are the same as the /ZCLAMP (Zero Clamping Input) signal allocations.</td> <td>Linear</td> </tr> </tbody> </table> | | | | | | | /P-DET (Polarity Detection Input) Signal Allocation | | Applicable Motors | n.X□□□ | 0 to F | The allocations are the same as the /ZCLAMP (Zero Clamping Input) signal allocations. | Linear | | | | | | | | | | | | | | | | | | | | | | | | | | | | | | | | | | | | | | | | | | | | | |
| /P-DET (Polarity Detection Input) Signal Allocation | | Applicable Motors | | | | | | | | | | | | | | | | | | | | | | | | | | | | | | | | | | | | | | | | | | | | | | | | | | | | | | | | | | |
| n.X□□□ | 0 to F | The allocations are the same as the /ZCLAMP (Zero Clamping Input) signal allocations. | Linear | | | | | | | | | | | | | | | | | | | | | | | | | | | | | | | | | | | | | | | | | | | | | | | | | | | | | | | | | |

Continued on next page.

5.1 SERVOPACKs with Analog Voltage/Pulse Train References

5.1.2 List of Parameters

Continued from previous page.

| Parameter No. | Size | Name | Setting Range | Setting Unit | Default Setting | Applicable Motors | When Enabled | Classification | Reference | |
|---------------|------|----------------------------|--|--|-----------------|-------------------|---------------|----------------|-----------|--|
| Pn50E | 2 | Output Signal Selections 1 | 0000h to 6666h | – | 3211h | All | After restart | Setup | *1 | |
| | | | /COIN (Positioning Completion Output) Signal Allocation | | | | | | | |
| | | | 0 | Disabled (the above signal output is not used). | | | | | | |
| | | | 1 | Output the signal from the CN1-25 or CN1-26 output terminal. | | | | | | |
| | | | 2 | Output the signal from the CN1-27 or CN1-28 output terminal. | | | | | | |
| | | | 3 | Output the signal from the CN1-29 or CN1-30 output terminal. | | | | | | |
| | | | 4 | Output the signal from the CN1-37 output terminal. | | | | | | |
| | | | 5 | Output the signal from the CN1-38 output terminal. | | | | | | |
| | | | 6 | Output the signal from the CN1-39 output terminal. | | | | | | |
| | | | /V-CMP (Speed Coincidence Detection Output) Signal Allocation | | | | | | | |
| | | | 0 to 6 | The allocations are the same as the /COIN (Positioning Completion) signal allocations. | | | | | | |
| | | | /TGON (Rotation Detection Output) Signal Allocation | | | | | | | |
| | | | 0 to 6 | The allocations are the same as the /COIN (Positioning Completion) signal allocations. | | | | | | |
| | | | /S-RDY (Servo Ready) Signal Allocation | | | | | | | |
| | | | 0 to 6 | The allocations are the same as the /COIN (Positioning Completion) signal allocations. | | | | | | |
| Pn50F | 2 | Output Signal Selections 2 | 0000h to 6666h | – | 0000h | All | After restart | Setup | *1 | |
| | | | /CLT (Torque Limit Detection Output) Signal Allocation | | | | | | | |
| | | | 0 | Disabled (the above signal output is not used). | | | | | | |
| | | | 1 | Output the signal from the CN1-25 or CN1-26 output terminal. | | | | | | |
| | | | 2 | Output the signal from the CN1-27 or CN1-28 output terminal. | | | | | | |
| | | | 3 | Output the signal from the CN1-29 or CN1-30 output terminal. | | | | | | |
| | | | 4 | Output the signal from the CN1-37 output terminal. | | | | | | |
| | | | 5 | Output the signal from the CN1-38 output terminal. | | | | | | |
| | | | 6 | Output the signal from the CN1-39 output terminal. | | | | | | |
| | | | /VLT (Speed Limit Detection) Signal Allocation | | | | | | | |
| | | | 0 to 6 | The allocations are the same as the /CLT (Torque Limit Detection Output) signal allocations. | | | | | | |
| | | | /BK (Brake Output) Signal Allocation | | | | | | | |
| | | | 0 to 6 | The allocations are the same as the /CLT (Torque Limit Detection Output) signal allocations. | | | | | | |
| | | | /WARN (Warning Output) Signal Allocation | | | | | | | |
| | | | 0 to 6 | The allocations are the same as the /CLT (Torque Limit Detection Output) signal allocations. | | | | | | |

Continued on next page.

Continued from previous page.

| Parameter No. | Size | Name | Setting Range | Setting Unit | Default Setting | Applicable Motors | When Enabled | Classification | Reference | |
|---------------|--------|---|--|--|-----------------|-------------------|---------------|----------------|-----------|--|
| Pn510 | 2 | Output Signal Selections 3 | 0000h to 0666h | - | 0000h | All | After restart | Setup | *1 | |
| | | | /NEAR (Near Output) Signal Allocation | | | | | | | |
| | n.□□□X | | 0 | Disabled (the above signal output is not used). | | | | | | |
| | | | 1 | Output the signal from the CN1-25 or CN1-26 output terminal. | | | | | | |
| | | | 2 | Output the signal from the CN1-27 or CN1-28 output terminal. | | | | | | |
| | | | 3 | Output the signal from the CN1-29 or CN1-30 output terminal. | | | | | | |
| | | | 4 | Output the signal from the CN1-37 output terminal. | | | | | | |
| | | | 5 | Output the signal from the CN1-38 output terminal. | | | | | | |
| | | | 6 | Output the signal from the CN1-39 output terminal. | | | | | | |
| | n.□□X□ | | Reserved parameter (Do not change.) | | | | | | | |
| | | /PSELA (Reference Pulse Input Multiplication Switching Output) Signal Allocation | | | | | | | | |
| n.□X□□ | | 0 to 6 | The allocations are the same as the /NEAR (Near) signal allocations. | | | | | | | |
| n.X□□□ | | Reserved parameter (Do not change.) | | | | | | | | |
| Pn512 | 2 | Output Signal Inverse Settings | 0000h to 1111h | - | 0000h | All | After restart | Setup | *1 | |
| | n.□□□X | | Output Signal Inversion for CN1-25 and CN1-26 Terminals | | | | | | | |
| | | | 0 | The signal is not inverted. | | | | | | |
| | | | 1 | The signal is inverted. | | | | | | |
| | n.□□X□ | | Output Signal Inversion for CN1-27 and CN1-28 Terminals | | | | | | | |
| | | | 0 | The signal is not inverted. | | | | | | |
| | | | 1 | The signal is inverted. | | | | | | |
| | n.□X□□ | | Output Signal Inversion for CN1-29 and CN1-30 Terminals | | | | | | | |
| | | | 0 | The signal is not inverted. | | | | | | |
| | | | 1 | The signal is inverted. | | | | | | |
| n.X□□□ | | Output Signal Inversion for CN1-37 Terminal | | | | | | | | |
| | | 0 | The signal is not inverted. | | | | | | | |
| | | 1 | The signal is inverted. | | | | | | | |
| Pn513 | 2 | Output Signal Inverse Settings 2 | 0000h to 0011h | - | 0000h | All | After restart | Setup | *1 | |
| | n.□□□X | | Output Signal Inversion for CN1-38 Terminal | | | | | | | |
| | | | 0 | The signal is not inverted. | | | | | | |
| | | | 1 | The signal is inverted. | | | | | | |
| | n.□□X□ | | Output Signal Inversion for CN1-39 Terminal | | | | | | | |
| | | | 0 | The signal is not inverted. | | | | | | |
| | | 1 | The signal is inverted. | | | | | | | |
| n.□X□□ | | Reserved parameter (Do not change.) | | | | | | | | |
| n.X□□□ | | Reserved parameter (Do not change.) | | | | | | | | |

Continued on next page.

5.1 SERVOPACKs with Analog Voltage/Pulse Train References

5.1.2 List of Parameters

Continued from previous page.

| Parameter No. | Size | Name | Setting Range | Setting Unit | Default Setting | Applicable Motors | When Enabled | Classification | Reference | |
|---------------|------|----------------------------|--|--|-----------------|-------------------|---------------|----------------|-----------|--|
| Pn514 | 2 | Output Signal Selections 4 | 0000h to 0666h | - | 0000h | All | After restart | Setup | *1 | |
| | | n.□□□X | Reserved parameter (Do not change.) | | | | | | | |
| | | n.□□X□ | Reserved parameter (Do not change.) | | | | | | | |
| | | n.□X□□ | /PM (Preventative Maintenance Output) Signal Allocation | | | | | | | |
| | | | 0 | Disabled (the above signal output is not used). | | | | | | |
| | | | 1 | Output the signal from the CN1-25 or CN1-26 output terminal. | | | | | | |
| | | | 2 | Output the signal from the CN1-27 or CN1-28 output terminal. | | | | | | |
| | | | 3 | Output the signal from the CN1-29 or CN1-30 output terminal. | | | | | | |
| | | | 4 | Output the signal from the CN1-37 output terminal. | | | | | | |
| | | | 5 | Output the signal from the CN1-38 output terminal. | | | | | | |
| | | 6 | Output the signal from the CN1-39 output terminal. | | | | | | | |
| | | n.X□□□ | Reserved parameter (Do not change.) | | | | | | | |

Continued on next page.

Continued from previous page.

| Parameter No. | Size | Name | Setting Range | Setting Unit | Default Setting | Applicable Motors | When Enabled | Classification | Reference | | | | | | | | | | | | | | | | | | | | | | | | | | | | | | | | | | | | | | | | | | | | | | | | | | | | | | | | | | | | | | | | | | | | | | | | | |
|---------------|---|---|----------------|--------------|-----------------|-------------------|---------------|----------------|-----------|--|---|--|---|---|---|---|---|---|---|---|---|---|---|---|---|---|--------|--------------------------------|---|------------------------------------|---|--|---|--|---|--|---|--|---|--|---|--|---|--|--|--|---|---|---|---|---|---|---|---|---|---|---|---|---|---|--------|---------------------------------|---|--------------------------------|---|--|---|--|---|--|---|--|---|--|---|--|---|--|--------|-------------------------------------|--------|-------------------------------------|
| Pn515 | 2 | Input Signal Selections 6 | 0000h to FFFFh | – | 8888h | All | After restart | Setup | *1 | | | | | | | | | | | | | | | | | | | | | | | | | | | | | | | | | | | | | | | | | | | | | | | | | | | | | | | | | | | | | | | | | | | | | | | | | |
| | <table border="1"> <thead> <tr> <th colspan="2">SEN (Absolute Data Request Input) Signal Allocation</th> </tr> </thead> <tbody> <tr><td>0</td><td>Active when CN1-40 input signal is ON (closed).</td></tr> <tr><td>1</td><td>Active when CN1-41 input signal is ON (closed).</td></tr> <tr><td>2</td><td>Active when CN1-42 input signal is ON (closed).</td></tr> <tr><td>3</td><td>Active when CN1-43 input signal is ON (closed).</td></tr> <tr><td>4</td><td>Active when CN1-44 input signal is ON (closed).</td></tr> <tr><td>5</td><td>Active when CN1-45 input signal is ON (closed).</td></tr> <tr><td>6</td><td>Active when CN1-46 input signal is ON (closed).</td></tr> <tr><td>n.□□□X</td><td>7 The signal is always active.</td></tr> <tr><td>8</td><td>Enable when 5 V is input to CN1-4.</td></tr> <tr><td>9</td><td>Active when CN1-40 input signal is OFF (open).</td></tr> <tr><td>A</td><td>Active when CN1-41 input signal is OFF (open).</td></tr> <tr><td>B</td><td>Active when CN1-42 input signal is OFF (open).</td></tr> <tr><td>C</td><td>Active when CN1-43 input signal is OFF (open).</td></tr> <tr><td>D</td><td>Active when CN1-44 input signal is OFF (open).</td></tr> <tr><td>E</td><td>Active when CN1-45 input signal is OFF (open).</td></tr> <tr><td>F</td><td>Active when CN1-46 input signal is OFF (open).</td></tr> </tbody> </table> <table border="1"> <thead> <tr> <th colspan="2">/PSEL (Reference Pulse Input Multiplication Switching Input) Signal Allocation</th> </tr> </thead> <tbody> <tr><td>0</td><td>Active when CN1-40 input signal is ON (closed).</td></tr> <tr><td>1</td><td>Active when CN1-41 input signal is ON (closed).</td></tr> <tr><td>2</td><td>Active when CN1-42 input signal is ON (closed).</td></tr> <tr><td>3</td><td>Active when CN1-43 input signal is ON (closed).</td></tr> <tr><td>4</td><td>Active when CN1-44 input signal is ON (closed).</td></tr> <tr><td>5</td><td>Active when CN1-45 input signal is ON (closed).</td></tr> <tr><td>6</td><td>Active when CN1-46 input signal is ON (closed).</td></tr> <tr><td>n.□□X□</td><td>7 The signal is always enabled.</td></tr> <tr><td>8</td><td>The signal is always inactive.</td></tr> <tr><td>9</td><td>Active when CN1-40 input signal is OFF (open).</td></tr> <tr><td>A</td><td>Active when CN1-41 input signal is OFF (open).</td></tr> <tr><td>B</td><td>Active when CN1-42 input signal is OFF (open).</td></tr> <tr><td>C</td><td>Active when CN1-43 input signal is OFF (open).</td></tr> <tr><td>D</td><td>Active when CN1-44 input signal is OFF (open).</td></tr> <tr><td>E</td><td>Active when CN1-45 input signal is OFF (open).</td></tr> <tr><td>F</td><td>Active when CN1-46 input signal is OFF (open).</td></tr> </tbody> </table> <table border="1"> <tr> <td>n.□□□□</td> <td>Reserved parameter (Do not change.)</td> </tr> <tr> <td>n.X□□□</td> <td>Reserved parameter (Do not change.)</td> </tr> </table> | | | | | | | | | | SEN (Absolute Data Request Input) Signal Allocation | | 0 | Active when CN1-40 input signal is ON (closed). | 1 | Active when CN1-41 input signal is ON (closed). | 2 | Active when CN1-42 input signal is ON (closed). | 3 | Active when CN1-43 input signal is ON (closed). | 4 | Active when CN1-44 input signal is ON (closed). | 5 | Active when CN1-45 input signal is ON (closed). | 6 | Active when CN1-46 input signal is ON (closed). | n.□□□X | 7 The signal is always active. | 8 | Enable when 5 V is input to CN1-4. | 9 | Active when CN1-40 input signal is OFF (open). | A | Active when CN1-41 input signal is OFF (open). | B | Active when CN1-42 input signal is OFF (open). | C | Active when CN1-43 input signal is OFF (open). | D | Active when CN1-44 input signal is OFF (open). | E | Active when CN1-45 input signal is OFF (open). | F | Active when CN1-46 input signal is OFF (open). | /PSEL (Reference Pulse Input Multiplication Switching Input) Signal Allocation | | 0 | Active when CN1-40 input signal is ON (closed). | 1 | Active when CN1-41 input signal is ON (closed). | 2 | Active when CN1-42 input signal is ON (closed). | 3 | Active when CN1-43 input signal is ON (closed). | 4 | Active when CN1-44 input signal is ON (closed). | 5 | Active when CN1-45 input signal is ON (closed). | 6 | Active when CN1-46 input signal is ON (closed). | n.□□X□ | 7 The signal is always enabled. | 8 | The signal is always inactive. | 9 | Active when CN1-40 input signal is OFF (open). | A | Active when CN1-41 input signal is OFF (open). | B | Active when CN1-42 input signal is OFF (open). | C | Active when CN1-43 input signal is OFF (open). | D | Active when CN1-44 input signal is OFF (open). | E | Active when CN1-45 input signal is OFF (open). | F | Active when CN1-46 input signal is OFF (open). | n.□□□□ | Reserved parameter (Do not change.) | n.X□□□ | Reserved parameter (Do not change.) |
| | SEN (Absolute Data Request Input) Signal Allocation | | | | | | | | | | | | | | | | | | | | | | | | | | | | | | | | | | | | | | | | | | | | | | | | | | | | | | | | | | | | | | | | | | | | | | | | | | | | | | | | | |
| | 0 | Active when CN1-40 input signal is ON (closed). | | | | | | | | | | | | | | | | | | | | | | | | | | | | | | | | | | | | | | | | | | | | | | | | | | | | | | | | | | | | | | | | | | | | | | | | | | | | | | | | |
| | 1 | Active when CN1-41 input signal is ON (closed). | | | | | | | | | | | | | | | | | | | | | | | | | | | | | | | | | | | | | | | | | | | | | | | | | | | | | | | | | | | | | | | | | | | | | | | | | | | | | | | | |
| | 2 | Active when CN1-42 input signal is ON (closed). | | | | | | | | | | | | | | | | | | | | | | | | | | | | | | | | | | | | | | | | | | | | | | | | | | | | | | | | | | | | | | | | | | | | | | | | | | | | | | | | |
| | 3 | Active when CN1-43 input signal is ON (closed). | | | | | | | | | | | | | | | | | | | | | | | | | | | | | | | | | | | | | | | | | | | | | | | | | | | | | | | | | | | | | | | | | | | | | | | | | | | | | | | | |
| | 4 | Active when CN1-44 input signal is ON (closed). | | | | | | | | | | | | | | | | | | | | | | | | | | | | | | | | | | | | | | | | | | | | | | | | | | | | | | | | | | | | | | | | | | | | | | | | | | | | | | | | |
| | 5 | Active when CN1-45 input signal is ON (closed). | | | | | | | | | | | | | | | | | | | | | | | | | | | | | | | | | | | | | | | | | | | | | | | | | | | | | | | | | | | | | | | | | | | | | | | | | | | | | | | | |
| | 6 | Active when CN1-46 input signal is ON (closed). | | | | | | | | | | | | | | | | | | | | | | | | | | | | | | | | | | | | | | | | | | | | | | | | | | | | | | | | | | | | | | | | | | | | | | | | | | | | | | | | |
| | n.□□□X | 7 The signal is always active. | | | | | | | | | | | | | | | | | | | | | | | | | | | | | | | | | | | | | | | | | | | | | | | | | | | | | | | | | | | | | | | | | | | | | | | | | | | | | | | | |
| | 8 | Enable when 5 V is input to CN1-4. | | | | | | | | | | | | | | | | | | | | | | | | | | | | | | | | | | | | | | | | | | | | | | | | | | | | | | | | | | | | | | | | | | | | | | | | | | | | | | | | |
| | 9 | Active when CN1-40 input signal is OFF (open). | | | | | | | | | | | | | | | | | | | | | | | | | | | | | | | | | | | | | | | | | | | | | | | | | | | | | | | | | | | | | | | | | | | | | | | | | | | | | | | | |
| | A | Active when CN1-41 input signal is OFF (open). | | | | | | | | | | | | | | | | | | | | | | | | | | | | | | | | | | | | | | | | | | | | | | | | | | | | | | | | | | | | | | | | | | | | | | | | | | | | | | | | |
| | B | Active when CN1-42 input signal is OFF (open). | | | | | | | | | | | | | | | | | | | | | | | | | | | | | | | | | | | | | | | | | | | | | | | | | | | | | | | | | | | | | | | | | | | | | | | | | | | | | | | | |
| | C | Active when CN1-43 input signal is OFF (open). | | | | | | | | | | | | | | | | | | | | | | | | | | | | | | | | | | | | | | | | | | | | | | | | | | | | | | | | | | | | | | | | | | | | | | | | | | | | | | | | |
| | D | Active when CN1-44 input signal is OFF (open). | | | | | | | | | | | | | | | | | | | | | | | | | | | | | | | | | | | | | | | | | | | | | | | | | | | | | | | | | | | | | | | | | | | | | | | | | | | | | | | | |
| | E | Active when CN1-45 input signal is OFF (open). | | | | | | | | | | | | | | | | | | | | | | | | | | | | | | | | | | | | | | | | | | | | | | | | | | | | | | | | | | | | | | | | | | | | | | | | | | | | | | | | |
| | F | Active when CN1-46 input signal is OFF (open). | | | | | | | | | | | | | | | | | | | | | | | | | | | | | | | | | | | | | | | | | | | | | | | | | | | | | | | | | | | | | | | | | | | | | | | | | | | | | | | | |
| | /PSEL (Reference Pulse Input Multiplication Switching Input) Signal Allocation | | | | | | | | | | | | | | | | | | | | | | | | | | | | | | | | | | | | | | | | | | | | | | | | | | | | | | | | | | | | | | | | | | | | | | | | | | | | | | | | | |
| | 0 | Active when CN1-40 input signal is ON (closed). | | | | | | | | | | | | | | | | | | | | | | | | | | | | | | | | | | | | | | | | | | | | | | | | | | | | | | | | | | | | | | | | | | | | | | | | | | | | | | | | |
| | 1 | Active when CN1-41 input signal is ON (closed). | | | | | | | | | | | | | | | | | | | | | | | | | | | | | | | | | | | | | | | | | | | | | | | | | | | | | | | | | | | | | | | | | | | | | | | | | | | | | | | | |
| | 2 | Active when CN1-42 input signal is ON (closed). | | | | | | | | | | | | | | | | | | | | | | | | | | | | | | | | | | | | | | | | | | | | | | | | | | | | | | | | | | | | | | | | | | | | | | | | | | | | | | | | |
| | 3 | Active when CN1-43 input signal is ON (closed). | | | | | | | | | | | | | | | | | | | | | | | | | | | | | | | | | | | | | | | | | | | | | | | | | | | | | | | | | | | | | | | | | | | | | | | | | | | | | | | | |
| | 4 | Active when CN1-44 input signal is ON (closed). | | | | | | | | | | | | | | | | | | | | | | | | | | | | | | | | | | | | | | | | | | | | | | | | | | | | | | | | | | | | | | | | | | | | | | | | | | | | | | | | |
| | 5 | Active when CN1-45 input signal is ON (closed). | | | | | | | | | | | | | | | | | | | | | | | | | | | | | | | | | | | | | | | | | | | | | | | | | | | | | | | | | | | | | | | | | | | | | | | | | | | | | | | | |
| | 6 | Active when CN1-46 input signal is ON (closed). | | | | | | | | | | | | | | | | | | | | | | | | | | | | | | | | | | | | | | | | | | | | | | | | | | | | | | | | | | | | | | | | | | | | | | | | | | | | | | | | |
| | n.□□X□ | 7 The signal is always enabled. | | | | | | | | | | | | | | | | | | | | | | | | | | | | | | | | | | | | | | | | | | | | | | | | | | | | | | | | | | | | | | | | | | | | | | | | | | | | | | | | |
| 8 | The signal is always inactive. | | | | | | | | | | | | | | | | | | | | | | | | | | | | | | | | | | | | | | | | | | | | | | | | | | | | | | | | | | | | | | | | | | | | | | | | | | | | | | | | | |
| 9 | Active when CN1-40 input signal is OFF (open). | | | | | | | | | | | | | | | | | | | | | | | | | | | | | | | | | | | | | | | | | | | | | | | | | | | | | | | | | | | | | | | | | | | | | | | | | | | | | | | | | |
| A | Active when CN1-41 input signal is OFF (open). | | | | | | | | | | | | | | | | | | | | | | | | | | | | | | | | | | | | | | | | | | | | | | | | | | | | | | | | | | | | | | | | | | | | | | | | | | | | | | | | | |
| B | Active when CN1-42 input signal is OFF (open). | | | | | | | | | | | | | | | | | | | | | | | | | | | | | | | | | | | | | | | | | | | | | | | | | | | | | | | | | | | | | | | | | | | | | | | | | | | | | | | | | |
| C | Active when CN1-43 input signal is OFF (open). | | | | | | | | | | | | | | | | | | | | | | | | | | | | | | | | | | | | | | | | | | | | | | | | | | | | | | | | | | | | | | | | | | | | | | | | | | | | | | | | | |
| D | Active when CN1-44 input signal is OFF (open). | | | | | | | | | | | | | | | | | | | | | | | | | | | | | | | | | | | | | | | | | | | | | | | | | | | | | | | | | | | | | | | | | | | | | | | | | | | | | | | | | |
| E | Active when CN1-45 input signal is OFF (open). | | | | | | | | | | | | | | | | | | | | | | | | | | | | | | | | | | | | | | | | | | | | | | | | | | | | | | | | | | | | | | | | | | | | | | | | | | | | | | | | | |
| F | Active when CN1-46 input signal is OFF (open). | | | | | | | | | | | | | | | | | | | | | | | | | | | | | | | | | | | | | | | | | | | | | | | | | | | | | | | | | | | | | | | | | | | | | | | | | | | | | | | | | |
| n.□□□□ | Reserved parameter (Do not change.) | | | | | | | | | | | | | | | | | | | | | | | | | | | | | | | | | | | | | | | | | | | | | | | | | | | | | | | | | | | | | | | | | | | | | | | | | | | | | | | | | |
| n.X□□□ | Reserved parameter (Do not change.) | | | | | | | | | | | | | | | | | | | | | | | | | | | | | | | | | | | | | | | | | | | | | | | | | | | | | | | | | | | | | | | | | | | | | | | | | | | | | | | | | |

Continued on next page.

5.1 SERVOPACKs with Analog Voltage/Pulse Train References

5.1.2 List of Parameters

Continued from previous page.

| Parameter No. | Size | Name | Setting Range | Setting Unit | Default Setting | Applicable Motors | When Enabled | Classification | Reference | |
|---------------|--------|--|--|---|-----------------|-------------------|---------------|----------------|-----------|--|
| Pn516 | 2 | Input Signal Selections 7 | 0000h to FFFFh | - | 8888h | All | After restart | Setup | *1 | |
| | n.□□□X | | FSTP (Forced Stop Input) Signal Allocation | | | | | | | |
| | | | 0 | Enable drive when CN1-40 input signal is ON (closed). | | | | | | |
| | | | 1 | Enable drive when CN1-41 input signal is ON (closed). | | | | | | |
| | | | 2 | Enable drive when CN1-42 input signal is ON (closed). | | | | | | |
| | | | 3 | Enable drive when CN1-43 input signal is ON (closed). | | | | | | |
| | | | 4 | Enable drive when CN1-44 input signal is ON (closed). | | | | | | |
| | | | 5 | Enable drive when CN1-45 input signal is ON (closed). | | | | | | |
| | | | 6 | Enable drive when CN1-46 input signal is ON (closed). | | | | | | |
| | | | 7 | Set the signal to always prohibit drive (always force the motor to stop). | | | | | | |
| | | | 8 | Set the signal to always enable drive (always disable forcing the motor to stop). | | | | | | |
| | | | 9 | Enable drive when CN1-40 input signal is OFF (open). | | | | | | |
| | | | A | Enable drive when CN1-41 input signal is OFF (open). | | | | | | |
| | | | B | Enable drive when CN1-42 input signal is OFF (open). | | | | | | |
| | | | C | Enable drive when CN1-43 input signal is OFF (open). | | | | | | |
| | | | D | Enable drive when CN1-44 input signal is OFF (open). | | | | | | |
| | | | E | Enable drive when CN1-45 input signal is OFF (open). | | | | | | |
| | | | F | Enable drive when CN1-46 input signal is OFF (open). | | | | | | |
| | | | n.□□□□ | Reserved parameter (Do not change.) | | | | | | |
| | | | n.□X□□ | Reserved parameter (Do not change.) | | | | | | |
| | | | n.X□□□ | Reserved parameter (Do not change.) | | | | | | |
| Pn517 | 2 | Output Signal Selections 5 | 0000h to 0666h | - | 0654h | All | After restart | Setup | *1 | |
| | n.□□□X | | ALO1 (Alarm Code Output) Signal Allocation | | | | | | | |
| | | | 0 | Disabled (the above signal output is not used). | | | | | | |
| | | | 1 | Output the signal from the CN1-25 or CN1-26 output terminal. | | | | | | |
| | | | 2 | Output the signal from the CN1-27 or CN1-28 output terminal. | | | | | | |
| | | | 3 | Output the signal from the CN1-29 or CN1-30 output terminal. | | | | | | |
| | | | 4 | Output the signal from the CN1-37 output terminal. | | | | | | |
| | | | 5 | Output the signal from the CN1-38 output terminal. | | | | | | |
| | | | 6 | Output the signal from the CN1-39 output terminal. | | | | | | |
| | n.□□□□ | | ALO2 (Alarm Code Output) Signal Allocation | | | | | | | |
| | | 0 to 6 | The allocations are the same as the ALO1 (Alarm Code Output) signal allocations. | | | | | | | |
| n.□X□□ | | ALO3 (Alarm Code Output) Signal Allocation | | | | | | | | |
| | | 0 to 6 | The allocations are the same as the ALO1 (Alarm Code Output) signal allocations. | | | | | | | |
| n.X□□□ | | Reserved parameter (Do not change.) | | | | | | | | |
| Pn518*3 | - | Safety Module-Related Parameters | - | - | - | All | - | - | - | |
| Pn51B | 4 | Motor-Load Position Deviation Overflow Detection Level | 0 to 1,073,741,824 | 1 reference unit | 1000 | Rotary | Immediately | Setup | *1 | |

Continued on next page.

Continued from previous page.

| Parameter No. | Size | Name | Setting Range | Setting Unit | Default Setting | Applicable Motors | When Enabled | Classification | Reference | | | | | | | | | | |
|---------------|-------------------------------------|---|--------------------|--|-----------------|-------------------|---------------|----------------|-----------|--|--|--|--|--|--|--|--|--|--|
| Pn51E | 2 | Position Deviation Overflow Warning Level | 10 to 100 | 1% | 100 | All | Immediately | Setup | *1 | | | | | | | | | | |
| Pn520 | 4 | Position Deviation Overflow Alarm Level | 1 to 1,073,741,823 | 1 reference unit | 5242880 | All | Immediately | Setup | *1 | | | | | | | | | | |
| Pn522 | 4 | Positioning Completed Width | 0 to 1,073,741,824 | 1 reference unit | 7 | All | Immediately | Setup | *1 | | | | | | | | | | |
| Pn524 | 4 | Near Signal Width | 1 to 1,073,741,824 | 1 reference unit | 1073741824 | All | Immediately | Setup | *1 | | | | | | | | | | |
| Pn526 | 4 | Position Deviation Overflow Alarm Level at Servo ON | 1 to 1,073,741,823 | 1 reference unit | 5242880 | All | Immediately | Setup | *1 | | | | | | | | | | |
| Pn528 | 2 | Position Deviation Overflow Warning Level at Servo ON | 10 to 100 | 1% | 100 | All | Immediately | Setup | *1 | | | | | | | | | | |
| Pn529 | 2 | Speed Limit Level at Servo ON | 0 to 10,000 | 1 min ⁻¹ | 10000 | Rotary | Immediately | Setup | *1 | | | | | | | | | | |
| Pn52A | 2 | Multiplier per Fully-closed Rotation | 0 to 100 | 1% | 20 | Rotary | Immediately | Tuning | *1 | | | | | | | | | | |
| Pn52B | 2 | Overload Warning Level | 1 to 100 | 1% | 20 | All | Immediately | Setup | *1 | | | | | | | | | | |
| Pn52C | 2 | Base Current Derating at Motor Overload Detection | 10 to 100 | 1% | 100 | All | After restart | Setup | *1 | | | | | | | | | | |
| Pn52F | 2 | Monitor Display at Startup | 0000h to 0FFFh | - | 0FFFh | All | Immediately | Setup | *1 | | | | | | | | | | |
| Pn530 | 2 | Program Jogging-Related Selections | 0000h to 0005h | - | 0000h | All | Immediately | Setup | *1 | | | | | | | | | | |
| | | | | | | | | | | Program Jogging Operation Pattern | | | | | | | | | |
| | | | | | | | | | | 0 | (Waiting time in Pn535 → Forward by travel distance in Pn531) × Number of movements in Pn536 | | | | | | | | |
| | | | | | | | | | | 1 | (Waiting time in Pn535 → Reverse by travel distance in Pn531) × Number of movements in Pn536 | | | | | | | | |
| | | | | | | | | | | 2 | (Waiting time in Pn535 → Forward by travel distance in Pn531) × Number of movements in Pn536 (Waiting time in Pn535 → Reverse by travel distance in Pn531) × Number of movements in Pn536 | | | | | | | | |
| | | | | | | | | | | 3 | (Waiting time in Pn535 → Reverse by travel distance in Pn531) × Number of movements in Pn536 (Waiting time in Pn535 → Forward by travel distance in Pn531) × Number of movements in Pn536 | | | | | | | | |
| | | | | | | | | | | 4 | (Waiting time in Pn535 → Forward by travel distance in Pn531 → Waiting time in Pn535 → Reverse by travel distance in Pn531) × Number of movements in Pn536 | | | | | | | | |
| | | | | | | | | | | 5 | (Waiting time in Pn535 → Reverse by travel distance in Pn531 → Waiting time in Pn535 → Forward by travel distance in Pn531) × Number of movements in Pn536 | | | | | | | | |
| | | | | | | | | | | n.□□□□ | Reserved parameter (Do not change.) | | | | | | | | |
| | | | | | | | | | | n.□X□□ | Reserved parameter (Do not change.) | | | | | | | | |
| n.X□□□ | Reserved parameter (Do not change.) | | | | | | | | | | | | | | | | | | |
| Pn531 | 4 | Program Jogging Travel Distance | 1 to 1,073,741,824 | 1 reference unit | 32768 | All | Immediately | Setup | *1 | | | | | | | | | | |
| Pn533 | 2 | Program Jogging Movement Speed | 1 to 10,000 | Rotary: 1 min ⁻¹ Direct Drive: 0.1 min ⁻¹ | 500 | Rotary | Immediately | Setup | *1 | | | | | | | | | | |

Continued on next page.

5.1 SERVOPACKs with Analog Voltage/Pulse Train References

5.1.2 List of Parameters

Continued from previous page.

| Parameter No. | Size | Name | Setting Range | Setting Unit | Default Setting | Applicable Motors | When Enabled | Classification | Reference | |
|---------------|--------|---|-------------------------------|---|-----------------|-------------------|---------------|----------------|-----------|--|
| Pn534 | 2 | Program Jogging Acceleration/Deceleration Time | 2 to 10,000 | 1 ms | 100 | All | Immediately | Setup | *1 | |
| Pn535 | 2 | Program Jogging Waiting Time | 0 to 10,000 | 1 ms | 100 | All | Immediately | Setup | *1 | |
| Pn536 | 2 | Program Jogging Number of Movements | 0 to 1,000 | Times | 1 | All | Immediately | Setup | *1 | |
| Pn550 | 2 | Analog Monitor 1 Offset Voltage | -10,000 to 10,000 | 0.1 V | 0 | All | Immediately | Setup | *1 | |
| Pn551 | 2 | Analog Monitor 2 Offset Voltage | -10,000 to 10,000 | 0.1 V | 0 | All | Immediately | Setup | *1 | |
| Pn552 | 2 | Analog Monitor 1 Magnification | -10,000 to 10,000 | × 0.01 | 100 | All | Immediately | Setup | *1 | |
| Pn553 | 2 | Analog Monitor 2 Magnification | -10,000 to 10,000 | × 0.01 | 100 | All | Immediately | Setup | *1 | |
| Pn55A | 2 | Power Consumption Monitor Unit Time | 1 to 1,440 | 1 min | 1 | All | Immediately | Setup | – | |
| Pn560 | 2 | Residual Vibration Detection Width | 1 to 3,000 | 0.1% | 400 | All | Immediately | Setup | | |
| Pn561 | 2 | Overshoot Detection Level | 0 to 100 | 1% | 100 | All | Immediately | Setup | *1 | |
| Pn580 | 2 | Zero Clamping Level | 0 to 10,000 | 1 mm/s | 10 | Linear | Immediately | Setup | *1 | |
| Pn581 | 2 | Zero Speed Level | 1 to 10,000 | 1 mm/s | 20 | Linear | Immediately | Setup | *1 | |
| Pn582 | 2 | Speed Coincidence Detection Signal Output Width | 0 to 100 | 1 mm/s | 10 | Linear | Immediately | Setup | *1 | |
| Pn583 | 2 | Brake Reference Output Speed Level | 0 to 10,000 | 1 mm/s | 10 | Linear | Immediately | Setup | *1 | |
| Pn584 | 2 | Speed Limit Level at Servo ON | 0 to 10,000 | 1 mm/s | 10000 | Linear | Immediately | Setup | *1 | |
| Pn585 | 2 | Program Jogging Movement Speed | 1 to 10,000 | 1 mm/s | 50 | Linear | Immediately | Setup | *1 | |
| Pn586 | 2 | Motor Running Cooling Ratio | 0 to 100 | 1%/Max. speed | 0 | Linear | Immediately | Setup | – | |
| Pn600 | 2 | Regenerative Resistor Capacity*4 | Depends on model.*5 | 10 W | 0 | All | Immediately | Setup | *1 | |
| Pn601 | 2 | Dynamic Brake Resistor Allowable Energy Consumption | 0 to 65,535 | 10 J | 0 | All | After restart | Setup | *6 | |
| Pn603 | 2 | Regenerative Resistance | 0 to 65,535 | 10 mΩ | 0 | All | Immediately | Setup | *1 | |
| Pn604 | 2 | Dynamic Brake Resistance | 0 to 65,535 | 10 mΩ | 0 | All | After restart | Setup | *6 | |
| Pn61A | 2 | Overheat Protection Selections | 0000h to 0003h | – | 0000h | Linear | After restart | Setup | *1 | |
| | n.□□□X | | Overheat Protection Selection | | | | | | | |
| | | | 0 | Disable overheat protection. | | | | | | |
| | | | 1 | Use overheat protection in the Yaskawa Linear Servomotor.*7 | | | | | | |
| | | | 2 | Monitor a negative voltage input from a sensor attached to the machine and use overheat protection. | | | | | | |
| | | | 3 | Monitor a positive voltage input from a sensor attached to the machine and use overheat protection. | | | | | | |
| n.□□□□ | | Reserved parameter (Do not change.) | | | | | | | | |
| n.□X□□ | | Reserved parameter (Do not change.) | | | | | | | | |
| n.X□□□ | | Reserved parameter (Do not change.) | | | | | | | | |

Continued on next page.

Continued from previous page.

| Parameter No. | Size | Name | Setting Range | Setting Unit | Default Setting | Applicable Motors | When Enabled | Classification | Reference |
|------------------------------|------|----------------------------------|---------------|--------------|-----------------|-------------------|--------------|----------------|-----------|
| Pn61B ^{*8} | 2 | Overheat Alarm Level | 0 to 500 | 0.01 V | 250 | All | Immediately | Setup | *1 |
| Pn61C ^{*8} | 2 | Overheat Warning Level | 0 to 100 | 1% | 100 | All | Immediately | Setup | *1 |
| Pn61D ^{*8} | 2 | Overheat Alarm Filter Time | 0 to 65,535 | 1 s | 0 | All | Immediately | Setup | *1 |
| Pn621 to Pn628 ^{*3} | – | Safety Module-Related Parameters | – | – | – | All | – | – | – |

*1. Refer to the following manual for details.

 Σ -7-Series Σ -7S SERVOPACK with Analog Voltage/Pulse Train References Product Manual (Manual No.: SIEP S800001 26)

*2. Set a percentage of the motor rated torque.

*3. These parameters are for SERVOPACKs with a Safety Module. Refer to the following manual for details.

 Σ -V-Series/ Σ -V-Series for Large-Capacity Models/ Σ -7-Series User's Manual Safety Module (Manual No.: SIEP C720829 06)

*4. Normally set this parameter to 0. If you use an External Regenerative Resistor, set the capacity (W) of the External Regenerative Resistor.

*5. The upper limit is the maximum output capacity (W) of the SERVOPACK.

*6. These parameters are for SERVOPACKs with the dynamic brake option. Refer to the following manual for details.

 Σ -7-Series Σ -7S/ Σ -7W SERVOPACK with Dynamic Brake Hardware Option Specifications Product Manual (Manual No.: SIEP S800001 73)

*7. The SGLFW2 is the only Yaskawa Linear Servomotor that supports this function.

*8. Enabled only when Pn61A is set to n.□□□2 or n.□□□3.

5.1.3 Parameter Recording Table

Use the following table to record the settings of the parameters.

| Parameter No. | Default Setting | | | | | Name | When Enabled |
|---------------|-----------------|--|--|--|--|--|---------------|
| Pn000 | 0000h | | | | | Basic Function Selections 0 | After restart |
| Pn001 | 0000h | | | | | Application Function Selections 1 | After restart |
| Pn002 | 0000h | | | | | Application Function Selections 2 | After restart |
| Pn006 | 0002h | | | | | Application Function Selections 6 | Immediately |
| Pn007 | 0000h | | | | | Application Function Selections 7 | Immediately |
| Pn008 | 0000h | | | | | Application Function Selections 8 | After restart |
| Pn009 | 0010h | | | | | Application Function Selections 9 | After restart |
| Pn00A | 0001h | | | | | Application Function Selections A | After restart |
| Pn00B | 0000h | | | | | Application Function Selections B | After restart |
| Pn00C | 0000h | | | | | Application Function Selections C | After restart |
| Pn00D | 0000h | | | | | Application Function Selections D | After restart |
| Pn00F | 0000h | | | | | Application Function Selections F | After restart |
| Pn010 | 0001h | | | | | Axis Address Selection for UART/USB Communications | After restart |
| Pn021 | 0000h | | | | | Reserved parameter | – |
| Pn022 | 0000h | | | | | Reserved parameter | – |
| Pn040 | 0000h | | | | | Σ -V Compatible Function Switch | After restart |
| Pn080 | 0000h | | | | | Application Function Selections 80 | After restart |
| Pn081 | 0000h | | | | | Application Function Selections 81 | After restart |
| Pn100 | 400 | | | | | Speed Loop Gain | Immediately |
| Pn101 | 2000 | | | | | Speed Loop Integral Time Constant | Immediately |
| Pn102 | 400 | | | | | Position Loop Gain | Immediately |
| Pn103 | 100 | | | | | Moment of Inertia Ratio | Immediately |
| Pn104 | 400 | | | | | Second Speed Loop Gain | Immediately |
| Pn105 | 2000 | | | | | Second Speed Loop Integral Time Constant | Immediately |
| Pn106 | 400 | | | | | Second Position Loop Gain | Immediately |
| Pn109 | 0 | | | | | Feedforward | Immediately |
| Pn10A | 0 | | | | | Feedforward Filter Time Constant | Immediately |
| Pn10B | 0004h | | | | | Gain Application Selections | * |
| Pn10C | 200 | | | | | Mode Switching Level for Torque Reference | Immediately |
| Pn10D | 0 | | | | | Mode Switching Level for Speed Reference | Immediately |

Continued on next page.

Continued from previous page.

| Parameter No. | Default Setting | | | | | Name | When Enabled |
|---------------|-----------------|--|--|--|--|---|---------------|
| Pn10E | 0 | | | | | Mode Switching Level for Acceleration | Immediately |
| Pn10F | 0 | | | | | Mode Switching Level for Position Deviation | Immediately |
| Pn11F | 0 | | | | | Position Integral Time Constant | Immediately |
| Pn121 | 100 | | | | | Friction Compensation Gain | Immediately |
| Pn122 | 100 | | | | | Second Friction Compensation Gain | Immediately |
| Pn123 | 0 | | | | | Friction Compensation Coefficient | Immediately |
| Pn124 | 0 | | | | | Friction Compensation Frequency Correction | Immediately |
| Pn125 | 100 | | | | | Friction Compensation Gain Correction | Immediately |
| Pn131 | 0 | | | | | Gain Switching Time 1 | Immediately |
| Pn132 | 0 | | | | | Gain Switching Time 2 | Immediately |
| Pn135 | 0 | | | | | Gain Switching Waiting Time 1 | Immediately |
| Pn136 | 0 | | | | | Gain Switching Waiting Time 2 | Immediately |
| Pn139 | 0000h | | | | | Automatic Gain Switching Selections 1 | Immediately |
| Pn13D | 2000 | | | | | Current Gain Level | Immediately |
| Pn13F | 0 | | | | | Less-Deviation Control 2 Second Position Integral Time Constant | Immediately |
| Pn140 | 0100h | | | | | Model Following Control-Related Selections | Immediately |
| Pn141 | 500 | | | | | Model Following Control Gain | Immediately |
| Pn142 | 1000 | | | | | Model Following Control Gain Correction | Immediately |
| Pn143 | 1000 | | | | | Model Following Control Bias in the Forward Direction | Immediately |
| Pn144 | 1000 | | | | | Model Following Control Bias in the Reverse Direction | Immediately |
| Pn145 | 500 | | | | | Vibration Suppression 1 Frequency A | Immediately |
| Pn146 | 700 | | | | | Vibration Suppression 1 Frequency B | Immediately |
| Pn147 | 1000 | | | | | Model Following Control Speed Feedforward Compensation | Immediately |
| Pn148 | 500 | | | | | Second Model Following Control Gain | Immediately |
| Pn149 | 1000 | | | | | Second Model Following Control Gain Correction | Immediately |
| Pn14A | 800 | | | | | Vibration Suppression 2 Frequency | Immediately |
| Pn14B | 100 | | | | | Vibration Suppression 2 Correction | Immediately |
| Pn14F | 0021h | | | | | Control-Related Selections | After restart |

Continued on next page.

5.1 SERVOPACKs with Analog Voltage/Pulse Train References

5.1.3 Parameter Recording Table

Continued from previous page.

| Parameter No. | Default Setting | | | | Name | When Enabled |
|---------------|-----------------|--|--|--|--|---------------|
| Pn160 | 0010h | | | | Anti-Resonance Control-Related Selections | Immediately |
| Pn161 | 1000 | | | | Anti-Resonance Frequency | Immediately |
| Pn162 | 100 | | | | Anti-Resonance Gain Correction | Immediately |
| Pn163 | 0 | | | | Anti-Resonance Damping Gain | Immediately |
| Pn164 | 0 | | | | Anti-Resonance Filter Time Constant 1 Correction | Immediately |
| Pn165 | 0 | | | | Anti-Resonance Filter Time Constant 2 Correction | Immediately |
| Pn166 | 0 | | | | Anti-Resonance Damping Gain 2 | Immediately |
| Pn170 | 1400h | | | | Tuning-less Function-Related Selections | * |
| Pn181 | 0 | | | | Mode Switching Level for Speed Reference | Immediately |
| Pn182 | 0 | | | | Mode Switching Level for Acceleration | Immediately |
| Pn190 | 0100h | | | | Less-Deviation Control-Related Switches | After restart |
| Pn191 | 1000 | | | | Less-Deviation Control 1 Feedforward Gain | Immediately |
| Pn192 | 1000 | | | | Less-Deviation Control 1 Second Feedforward Gain | Immediately |
| Pn193 | 30 | | | | Less-Deviation Control 1 Feedforward Filter Time Constant | Immediately |
| Pn195 | 2102h | | | | Less-Deviation Function Selection Switches | After restart |
| Pn196 | 1000 | | | | Less-Deviation Control 2 Speed Feedforward Gain | Immediately |
| Pn197 | 50 | | | | Less-Deviation Control 2 Torque Feedforward Filter Time Constant | Immediately |
| Pn198 | 1000 | | | | Less-Deviation Control 2 Forward Torque Feedforward Gain | Immediately |
| Pn199 | 1000 | | | | Less-Deviation Control 2 Reverse Torque Feedforward Gain | Immediately |
| Pn19A | 10000 | | | | Less-Deviation Control 2 Incomplete Integration Rate | Immediately |
| Pn19B | 0 | | | | Less-Deviation Control 2 Rotary Servomotor Viscous Friction Compensation Coefficient | Immediately |
| Pn19C | 0 | | | | Reserved parameter | Immediately |
| Pn19D | 0 | | | | Less-Deviation Control 2 Linear Servomotor Viscous Friction Compensation Coefficient | Immediately |
| Pn19E | 0 | | | | Reserved parameter | Immediately |
| Pn19F | 0 | | | | Less-Deviation Control 2 Torque Feedforward Moving Average Time | Immediately |
| Pn1A4 | 36 | | | | Reserved parameter | Immediately |

Continued on next page.

Continued from previous page.

| Parameter No. | Default Setting | | | | Name | When Enabled |
|---------------|-----------------|--|--|--|---|-----------------------------------|
| Pn1A5 | 0 | | | | Reserved parameter | Immediately |
| Pn1AE | 0 | | | | Reserved parameter | Immediately |
| Pn1AF | 0 | | | | Reserved parameter | Immediately |
| Pn200 | 0000h | | | | Position Control Reference Form Selections | After restart |
| Pn205 | 65535 | | | | Multiturn Limit | After restart |
| Pn207 | 1000h | | | | Position Control Function Selections | After restart |
| Pn20A | 32768 | | | | Number of External Scale Pitches | After restart |
| Pn20E | 64 | | | | Electronic Gear Ratio (Numerator) | After restart |
| Pn210 | 1 | | | | Electronic Gear Ratio (Denominator) | After restart |
| Pn212 | 2048 | | | | Number of Encoder Output Pulses | After restart |
| Pn216 | 0 | | | | Position Reference Acceleration/Deceleration Time Constant | Immediately after the motor stops |
| Pn217 | 0 | | | | Average Position Reference Movement Time | Immediately after the motor stops |
| Pn218 | 1 | | | | Reference Pulse Input Multiplier | Immediately |
| Pn22A | 0000h | | | | Fully-closed Control Selections | After restart |
| Pn234 | 0 | | | | Second Position Reference Acceleration/Deceleration Time Constant | Immediately |
| Pn281 | 20 | | | | Encoder Output Resolution | After restart |
| Pn282 | 0 | | | | Linear Encoder Scale Pitch | After restart |
| Pn300 | 600 | | | | Speed Reference Input Gain | Immediately |
| Pn301 | 100 | | | | Internal Set Speed 1 | Immediately |
| Pn302 | 200 | | | | Internal Set Speed 2 | Immediately |
| Pn303 | 300 | | | | Internal Set Speed 3 | Immediately |
| Pn304 | 500 | | | | Jogging Speed | Immediately |
| Pn305 | 0 | | | | Soft Start Acceleration Time | Immediately |
| Pn306 | 0 | | | | Soft Start Deceleration Time | Immediately |
| Pn307 | 40 | | | | Speed Reference Filter Time Constant | Immediately |
| Pn308 | 0 | | | | Speed Feedback Filter Time Constant | Immediately |
| Pn30A | 0 | | | | Deceleration Time for Servo OFF and Forced Stops | Immediately |
| Pn30C | 0 | | | | Speed Feedforward Average Movement Time | Immediately |
| Pn310 | 0000h | | | | Vibration Detection Selections | Immediately |
| Pn311 | 100 | | | | Vibration Detection Sensitivity | Immediately |
| Pn312 | 50 | | | | Vibration Detection Level | Immediately |
| Pn316 | 10000 | | | | Maximum Motor Speed | After restart |

Continued on next page.

5.1 SERVOPACKs with Analog Voltage/Pulse Train References

5.1.3 Parameter Recording Table

Continued from previous page.

| Parameter No. | Default Setting | | | | | Name | When Enabled |
|---------------|-----------------|--|--|--|--|--|---------------|
| Pn324 | 300 | | | | | Moment of Inertia Calculation Starting Level | Immediately |
| Pn380 | 10 | | | | | Internal Set Speed 1 | Immediately |
| Pn381 | 20 | | | | | Internal Set Speed 2 | Immediately |
| Pn382 | 30 | | | | | Internal Set Speed 3 | Immediately |
| Pn383 | 50 | | | | | Jogging Speed | Immediately |
| Pn384 | 10 | | | | | Vibration Detection Level | Immediately |
| Pn385 | 50 | | | | | Maximum Motor Speed | After restart |
| Pn400 | 30 | | | | | Torque Reference Input Gain | Immediately |
| Pn401 | 100 | | | | | First Stage First Torque Reference Filter Time Constant | Immediately |
| Pn402 | 800 | | | | | Forward Torque Limit | Immediately |
| Pn403 | 800 | | | | | Reverse Torque Limit | Immediately |
| Pn404 | 100 | | | | | Forward External Torque Limit | Immediately |
| Pn405 | 100 | | | | | Reverse External Torque Limit | Immediately |
| Pn406 | 800 | | | | | Emergency Stop Torque | Immediately |
| Pn407 | 10000 | | | | | Speed Limit during Torque Control | Immediately |
| Pn408 | 0000h | | | | | Torque-Related Function Selections | * |
| Pn409 | 5000 | | | | | First Stage Notch Filter Frequency | Immediately |
| Pn40A | 70 | | | | | First Stage Notch Filter Q Value | Immediately |
| Pn40B | 0 | | | | | First Stage Notch Filter Depth | Immediately |
| Pn40C | 5000 | | | | | Second Stage Notch Filter Frequency | Immediately |
| Pn40D | 70 | | | | | Second Stage Notch Filter Q Value | Immediately |
| Pn40E | 0 | | | | | Second Stage Notch Filter Depth | Immediately |
| Pn40F | 5000 | | | | | Second Stage Second Torque Reference Filter Frequency | Immediately |
| Pn410 | 50 | | | | | Second Stage Second Torque Reference Filter Q Value | Immediately |
| Pn412 | 100 | | | | | First Stage Second Torque Reference Filter Time Constant | Immediately |
| Pn415 | 0 | | | | | T-REF Filter Time Constant | Immediately |
| Pn416 | 0000h | | | | | Torque-Related Function Selections 2 | Immediately |
| Pn417 | 5000 | | | | | Third Stage Notch Filter Frequency | Immediately |
| Pn418 | 70 | | | | | Third Stage Notch Filter Q Value | Immediately |
| Pn419 | 0 | | | | | Third Stage Notch Filter Depth | Immediately |

Continued on next page.

Continued from previous page.

| Parameter No. | Default Setting | | | | Name | When Enabled |
|---------------|-----------------|--|--|--|---|---------------|
| Pn41A | 5000 | | | | Fourth Stage Notch Filter Frequency | Immediately |
| Pn41B | 70 | | | | Fourth Stage Notch Filter Q Value | Immediately |
| Pn41C | 0 | | | | Fourth Stage Notch Filter Depth | Immediately |
| Pn41D | 5000 | | | | Fifth Stage Notch Filter Frequency | Immediately |
| Pn41E | 70 | | | | Fifth Stage Notch Filter Q Value | Immediately |
| Pn41F | 0 | | | | Fifth Stage Notch Filter Depth | Immediately |
| Pn423 | 0000h | | | | Speed Ripple Compensation Selections | * |
| Pn424 | 50 | | | | Torque Limit at Main Circuit Voltage Drop | Immediately |
| Pn425 | 100 | | | | Release Time for Torque Limit at Main Circuit Voltage Drop | Immediately |
| Pn426 | 0 | | | | Torque Feedforward Average Movement Time | Immediately |
| Pn427 | 0 | | | | Speed Ripple Compensation Enable Speed | Immediately |
| Pn456 | 15 | | | | Sweep Torque Reference Amplitude | Immediately |
| Pn460 | 0101h | | | | Notch Filter Adjustment Selections 1 | Immediately |
| Pn475 | 0000h | | | | Gravity Compensation-Related Selections | After restart |
| Pn476 | 0 | | | | Gravity Compensation Torque | Immediately |
| Pn480 | 10000 | | | | Speed Limit during Force Control | Immediately |
| Pn481 | 400 | | | | Polarity Detection Speed Loop Gain | Immediately |
| Pn482 | 3000 | | | | Polarity Detection Speed Loop Integral Time Constant | Immediately |
| Pn483 | 30 | | | | Forward Force Limit | Immediately |
| Pn484 | 30 | | | | Reverse Force Limit | Immediately |
| Pn485 | 20 | | | | Polarity Detection Reference Speed | Immediately |
| Pn486 | 25 | | | | Polarity Detection Reference Acceleration/Deceleration Time | Immediately |
| Pn487 | 0 | | | | Polarity Detection Constant Speed Time | Immediately |
| Pn488 | 100 | | | | Polarity Detection Reference Waiting Time | Immediately |
| Pn48E | 10 | | | | Polarity Detection Range | Immediately |
| Pn490 | 100 | | | | Polarity Detection Load Level | Immediately |
| Pn495 | 100 | | | | Polarity Detection Confirmation Force Reference | Immediately |
| Pn498 | 10 | | | | Polarity Detection Allowable Error Range | Immediately |

Continued on next page.

5.1 SERVOPACKs with Analog Voltage/Pulse Train References

5.1.3 Parameter Recording Table

Continued from previous page.

| Parameter No. | Default Setting | | | | | Name | When Enabled |
|---------------|-----------------|--|--|--|--|--|---------------|
| Pn49F | 0 | | | | | Speed Ripple Compensation Enable Speed | Immediately |
| Pn501 | 10 | | | | | Zero Clamping Level | Immediately |
| Pn502 | 20 | | | | | Rotation Detection Level | Immediately |
| Pn503 | 10 | | | | | Speed Coincidence Detection Signal Output Width | Immediately |
| Pn506 | 0 | | | | | Brake Reference-Servo OFF Delay Time | Immediately |
| Pn507 | 100 | | | | | Brake Reference Output Speed Level | Immediately |
| Pn508 | 50 | | | | | Servo OFF-Brake Command Waiting Time | Immediately |
| Pn509 | 20 | | | | | Momentary Power Interruption Hold Time | Immediately |
| Pn50A | 2100h | | | | | Input Signal Selections 1 | After restart |
| Pn50B | 6543h | | | | | Input Signal Selections 2 | After restart |
| Pn50C | 8888h | | | | | Input Signal Selections 3 | After restart |
| Pn50D | 8888h | | | | | Input Signal Selections 4 | After restart |
| Pn50E | 3211h | | | | | Output Signal Selections 1 | After restart |
| Pn50F | 0000h | | | | | Output Signal Selections 2 | After restart |
| Pn510 | 0000h | | | | | Output Signal Selections 3 | After restart |
| Pn512 | 0000h | | | | | Output Signal Inverse Settings | After restart |
| Pn513 | 0000h | | | | | Output Signal Inverse Settings 2 | After restart |
| Pn514 | 0000h | | | | | Output Signal Selections 4 | After restart |
| Pn515 | 8888h | | | | | Input Signal Selections 6 | After restart |
| Pn516 | 8888h | | | | | Input Signal Selections 7 | After restart |
| Pn517 | 0654h | | | | | Output Signal Selections 5 | After restart |
| Pn51B | 1000 | | | | | Motor-Load Position Deviation Overflow Detection Level | Immediately |
| Pn51E | 100 | | | | | Position Deviation Overflow Warning Level | Immediately |
| Pn520 | 5242880 | | | | | Position Deviation Overflow Alarm Level | Immediately |
| Pn522 | 7 | | | | | Positioning Completed Width | Immediately |
| Pn524 | 1073741824 | | | | | Near Signal Width | Immediately |
| Pn526 | 5242880 | | | | | Position Deviation Overflow Alarm Level at Servo ON | Immediately |
| Pn528 | 100 | | | | | Position Deviation Overflow Warning Level at Servo ON | Immediately |
| Pn529 | 10000 | | | | | Speed Limit Level at Servo ON | Immediately |
| Pn52A | 20 | | | | | Multiplier per Fully-closed Rotation | Immediately |
| Pn52B | 20 | | | | | Overload Warning Level | Immediately |
| Pn52C | 100 | | | | | Base Current Derating at Motor Overload Detection | After restart |
| Pn52F | 0FFFh | | | | | Monitor Display at Startup | Immediately |

Continued on next page.

Continued from previous page.

| Parameter No. | Default Setting | | | | Name | When Enabled |
|---------------|-----------------|--|--|--|---|---------------|
| Pn530 | 0000h | | | | Program Jogging-Related Selections | Immediately |
| Pn531 | 32768 | | | | Program Jogging Travel Distance | Immediately |
| Pn533 | 500 | | | | Program Jogging Movement Speed | Immediately |
| Pn534 | 100 | | | | Program Jogging Acceleration/Deceleration Time | Immediately |
| Pn535 | 100 | | | | Program Jogging Waiting Time | Immediately |
| Pn536 | 1 | | | | Program Jogging Number of Movements | Immediately |
| Pn550 | 0 | | | | Analog Monitor 1 Offset Voltage | Immediately |
| Pn551 | 0 | | | | Analog Monitor 2 Offset Voltage | Immediately |
| Pn552 | 100 | | | | Analog Monitor 1 Magnification | Immediately |
| Pn553 | 100 | | | | Analog Monitor 2 Magnification | Immediately |
| Pn55A | 1 | | | | Power Consumption Monitor Unit Time | Immediately |
| Pn560 | 400 | | | | Residual Vibration Detection Width | Immediately |
| Pn561 | 100 | | | | Overshoot Detection Level | Immediately |
| Pn580 | 10 | | | | Zero Clamping Level | Immediately |
| Pn581 | 20 | | | | Zero Speed Level | Immediately |
| Pn582 | 10 | | | | Speed Coincidence Detection Signal Output Width | Immediately |
| Pn583 | 10 | | | | Brake Reference Output Speed Level | Immediately |
| Pn584 | 10000 | | | | Speed Limit Level at Servo ON | Immediately |
| Pn585 | 50 | | | | Program Jogging Movement Speed | Immediately |
| Pn586 | 0 | | | | Motor Running Cooling Ratio | Immediately |
| Pn600 | 0 | | | | Regenerative Resistor Capacity | Immediately |
| Pn601 | 0 | | | | Dynamic Brake Resistor Allowable Energy Consumption | After restart |
| Pn603 | 0 | | | | Regenerative Resistance | Immediately |
| Pn604 | 0 | | | | Dynamic Brake Resistance | After restart |
| Pn61A | 0000h | | | | Overheat Protection Selections | After restart |
| Pn61B | 250 | | | | Overheat Alarm Level | Immediately |
| Pn61C | 100 | | | | Overheat Warning Level | Immediately |
| Pn61D | 0 | | | | Overheat Alarm Filter Time | Immediately |

* The enable timing depends on the digit that is changed. Refer to the following section for details.

 5.1.2 List of Parameters on page 5-3

5.2 SERVOPACKs with MECHATROLINK-III Communications References

5.2.1 Interpreting the Parameter Lists

List of Servo Parameters

The types of motors to which the parameter applies.

- All: The parameter is used for both Rotary Servomotors and Linear Servomotors.
- Rotary: The parameter is used for only Rotary Servomotors.
- Linear: The parameter is used for only Linear Servomotors.

Rotary Servomotor terms are used for parameters that are applicable to all Servomotors. If you are using a Linear Servomotor, you need to interpret the terms accordingly. Refer to the following section for details.

◆ Differences in Terms for Rotary Servomotors and Linear Servomotors on page xii

“After restart” indicates parameters that will be effective after one of the following is executed.

- The power supply is turned OFF and ON again.
- The CONFIG command is sent.
- A software reset is executed.

| Parameter No. | Size | Name | Setting Range | Setting Unit | Default Setting | Applicable Motors | When Enabled | Classification | Reference | |
|--------------------|--|---|---|--------------|-----------------|-------------------|---------------|----------------|-----------|--|
| Pn000 M3 | 2 | Basic Function Selections 0 | 0000h to 10B1h | - | 0000h | All | After restart | Setup | - | |
| | n.□□□X | Rotation Direction Selection | | Reference | | | | | | |
| | | Movement Direction Selection | | | | | | | | |
| | 0 | Use CCW as the forward direction. | | - | | | | | | |
| | | Use the direction in which the linear encoder counts up as the forward direction. | | | | | | | | |
| | 1 | Use CW as the forward direction. (Reverse Rotation Mode) | | | | | | | | |
| | | Use the direction in which the linear encoder counts down as the forward direction. (Reverse Movement Mode) | | | | | | | | |
| | <p>Symbols are provided when a parameter is valid only for a specific profile.</p> <ul style="list-style-type: none"> • M2 Parameters that are valid only for a MECHATROLINK-II-compatible profile. • M3 Parameters that are valid only for a MECHATROLINK-III standard servo profile. | | | | | | | | | |
| | n.X□□□ | Rotary/Linear Servomotor Startup Selection When Encoder Is Not Connected | | Reference | | | | | | |
| | | 0 | When an encoder is not connected, start as SERVOPACK for Rotary Servomotor. | | | | | | | |
| 1 | When an encoder is not connected, start as SERVOPACK for Linear Servomotor. | | | | | | | | | |

If there are differences in the parameters for Rotary Servomotor and Linear Servomotor, information is provided for both.

- Top row: For Rotary Servomotors
- Bottom row: For Linear Servomotors

There are the following two classifications.

- Setup
- Tuning

Refer to the following manual for details.

Σ-7-Series Σ-7S SERVOPACK with MECHATROLINK-III Communications References Product Manual (Manual No.: SIEP S800001 28)

List of MECHATROLINK-III Common Parameters

The types of motors to which the parameter applies.

- All: The parameter is used for both Rotary Servomotors and Linear Servomotors.
- Rotary: The parameter is used for only Rotary Servomotors.
- Linear: The parameter is used for only Linear Servomotors.

Rotary Servomotor terms are used for parameters that are applicable to all Servomotors. If you are using a Linear Servomotor, you need to interpret the terms accordingly. Refer to the following section for details.

 **Differences in Terms for Rotary Servomotors and Linear Servomotors on page xii**

Indicates when a change to the parameter will be effective.

"After restart" indicates parameters that will be effective after one of the following is executed.

- The power supply is turned OFF and ON again.
- The CONFIG command is sent.
- A software reset is executed.

| Parameter No. | Size | Name | Setting Range | Setting Unit [Resolution] | Default Setting | Applicable Motors | When Enabled | Classification |
|---------------|------|-----------------|----------------------|---------------------------|-----------------|-------------------|--------------|----------------|
| 61 PnAC2 | 4 | Speed Loop Gain | 1,000h to 2,000,000h | 0.001 Hz [0.1 Hz] | 40000h | All | Immediately | Tuning |

You can set the parameter in increments of the setting unit. However, if a unit is given in square brackets, the setting is automatically converted to the resolution given in the square brackets.

5.2.2 List of Servo Parameters

The following table lists the parameters.

Note: Do not change the following parameters from their default settings.

- Reserved parameter
- Parameters not given in this manual
- Parameters that are not valid for the Servomotor that you are using, as given in the parameter table

| Parameter No. | Size | Name | Setting Range | Setting Unit | Default Setting | Applicable Motors | When Enabled | Classification | Reference | |
|---------------|---|---|---|--------------|-----------------|-------------------|---------------|----------------|-----------|--|
| Pn000 | 2 | Basic Function Selections 0 | 0000h to 10B1h | - | 0000h | All | After restart | Setup | *1 | |
| | n.□□□X | Rotation Direction Selection | | | | | | | | |
| | | Movement Direction Selection | | | | | | | | |
| | | 0 | Use CCW as the forward direction. | | | | | | | |
| | | 1 | Use the direction in which the linear encoder counts up as the forward direction. | | | | | | | |
| | n.X□□□ | 0 | Use CW as the forward direction. (Reverse Rotation Mode) | | | | | | | |
| | | 1 | Use the direction in which the linear encoder counts down as the forward direction. (Reverse Movement Mode) | | | | | | | |
| | n.□□X□ | Reserved parameter (Do not change.) | | | | | | | | |
| | n.□X□□ | Reserved parameter (Do not change.) | | | | | | | | |
| | n.X□□□ | Rotary/Linear Servomotor Startup Selection When Encoder Is Not Connected | | | | | | | | |
| 0 | | When an encoder is not connected, start as SERVOPACK for Rotary Servomotor. | | | | | | | | |
| 1 | When an encoder is not connected, start as SERVOPACK for Linear Servomotor. | | | | | | | | | |

Continued on next page.

Continued from previous page.

| Parameter No. | Size | Name | Setting Range | Setting Unit | Default Setting | Applicable Motors | When Enabled | Classification | Reference | |
|---------------|--------|-----------------------------------|---|---|-----------------|-------------------|---------------|----------------|-----------|--|
| Pn001 | 2 | Application Function Selections 1 | 0000h to 1142h | - | 0000h | All | After restart | Setup | *1 | |
| | | | Motor Stopping Method for Servo OFF and Group 1 Alarms | | | | | | | |
| | n.□□□X | | 0 | Stop the motor by applying the dynamic brake. | | | | | | |
| | n.□□□X | | 1 | Stop the motor by the applying dynamic brake and then release the dynamic brake. | | | | | | |
| | n.□□□X | | 2 | Coast the motor to a stop without the dynamic brake. | | | | | | |
| | | | Overtravel Stopping Method | | | | | | | |
| | n.□□X□ | | 0 | Apply the dynamic brake or coast the motor to a stop (use the stopping method set in Pn001 = n.□□□X). | | | | | | |
| | n.□□X□ | | 1 | Decelerate the motor to a stop using the torque set in Pn406 as the maximum torque and then servo-lock the motor. | | | | | | |
| | n.□□X□ | | 2 | Decelerate the motor to a stop using the torque set in Pn406 as the maximum torque and then let the motor coast. | | | | | | |
| | n.□□X□ | | 3 | Decelerate the motor to a stop using the deceleration time set in Pn30A and then servo-lock the motor. | | | | | | |
| | n.□□X□ | | 4 | Decelerate the motor to a stop using the deceleration time set in Pn30A and then let the motor coast. | | | | | | |
| | | | Main Circuit Power Supply AC/DC Input Selection | | | | | | | |
| | n.□X□□ | | 0 | Input AC power as the main circuit power supply using the L1, L2, and L3 terminals (do not use shared converter). | | | | | | |
| | n.□X□□ | | 1 | Input DC power as the main circuit power supply using the B1/⊕ and ⊖ 2 terminals or the B1 and ⊖ 2 terminals (use an external converter or the shared converter). | | | | | | |
| | n.X□□□ | | Reserved parameter (Do not change.) | | | | | | | |

Continued on next page.

Continued from previous page.

| Parameter No. | Size | Name | Setting Range | Setting Unit | Default Setting | Applicable Motors | When Enabled | Classification | Reference | |
|---------------|--------|-----------------------------------|---|---|-----------------|-------------------|--------------------------|------------------|-----------|--|
| Pn002 | 2 | Application Function Selections 2 | 0000h to 4213h | – | 0011h | – | After restart | Setup | – | |
| | | | MECHATROLINK Command Position and Speed Control Option | | | | Applicable Motors | Reference | | |
| | n.□□□X | | 0 | Reserved setting (Do not use.) | | | All | *2 | | |
| | | | 1 | Use TLIM as the torque limit. | | | | | | |
| | | | 2 | Reserved setting (Do not use.) | | | | | | |
| | | | 3 | Reserved setting (Do not use.) | | | | | | |
| | | | Torque Control Option | | | | Applicable Motors | Reference | | |
| | n.□□X□ | | 0 | Reserved setting (Do not use.) | | | All | *2 | | |
| | | | 1 | Use the speed limit for torque control (VLIM) as the speed limit. | | | | | | |
| | | | Encoder Usage | | | | Applicable Motors | Reference | | |
| | n.□X□□ | | 0 | Use the encoder according to encoder specifications. | | | All | *1 | | |
| | | | 1 | Use the encoder as an incremental encoder. | | | | | | |
| | | | 2 | Use the encoder as a single-turn absolute encoder. | | | Rotary | | | |
| | | | External Encoder Usage | | | | Applicable Motors | Reference | | |
| | n.X□□□ | | 0 | Do not use an external encoder. | | | Rotary | *1 | | |
| | | | 1 | The external encoder moves in the forward direction for CCW motor rotation. | | | | | | |
| | | | 2 | Reserved setting (Do not use.) | | | | | | |
| | | | 3 | The external encoder moves in the reverse direction for CCW motor rotation. | | | | | | |
| | | | 4 | Reserved setting (Do not use.) | | | | | | |

Continued on next page.

Continued from previous page.

| Parameter No. | Size | Name | Setting Range | Setting Unit | Default Setting | Applicable Motors | When Enabled | Classification | Reference | | |
|---------------|--------|--|---|--------------|-----------------|-------------------|--------------|----------------|-----------|--|--|
| Pn006 | 2 | Application Function Selections 6 | 0000h to 105Fh | - | 0002h | All | Immediately | Setup | *1 | | |
| | n.□□XX | Analog Monitor 1 Signal Selection | | | | | | | | | |
| | | 00 | Motor speed (1 V/1,000 min ⁻¹) Motor speed (1 V/1,000 mm/s) | | | | | | | | |
| | | 01 | Speed reference (1 V/1,000 min ⁻¹) Speed reference (1 V/1,000 mm/s) | | | | | | | | |
| | | 02 | Torque reference (1 V/100% rated torque) Force reference (1 V/100% rated force) | | | | | | | | |
| | | 03 | Position deviation (0.05 V/reference unit) | | | | | | | | |
| | | 04 | Position amplifier deviation (after electronic gear) (0.05 V/encoder pulse unit) Position amplifier deviation (after electronic gear) (0.05 V/linear encoder pulse unit) | | | | | | | | |
| | | 05 | Position reference speed (1 V/1,000 min ⁻¹) Position reference speed (1 V/1,000 mm/s) | | | | | | | | |
| | | 06 | Reserved setting (Do not use.) | | | | | | | | |
| | | 07 | Load-motor position deviation (0.01 V/reference unit) | | | | | | | | |
| | | 08 | Positioning completion (positioning completed: 5 V, positioning not completed: 0 V) | | | | | | | | |
| | | 09 | Speed feedforward (1 V/1,000 min ⁻¹) Speed feedforward (1 V/1,000 mm/s) | | | | | | | | |
| | | 0A | Torque feedforward (1 V/100% rated torque) Force feedforward (1 V/100% rated force) | | | | | | | | |
| | | 0B | Active gain (1st gain: 1 V, 2nd gain: 2 V) | | | | | | | | |
| | | 0C | Completion of position reference distribution (completed: 5 V, not completed: 0 V) | | | | | | | | |
| | | 0D | External encoder speed (1 V/1,000 min ⁻¹ : value at the motor shaft) | | | | | | | | |
| | | 0E | Reserved setting (Do not use.) | | | | | | | | |
| | | 0F | Reserved setting (Do not use.) | | | | | | | | |
| | | 10 | Main circuit DC voltage | | | | | | | | |
| | | 11 to 24 | Reserved settings (Do not use.) | | | | | | | | |
| | | 25 | Position deviation after position reference filter (0.05 V/reference unit) | | | | | | | | |
| | | 26 to 5F | Reserved settings (Do not use.) | | | | | | | | |
| | | n.□X□□ | Reserved parameter (Do not change.) | | | | | | | | |
| | | n.X□□□ | Reserved parameter (Do not change.) | | | | | | | | |

Continued on next page.

Continued from previous page.

| Parameter No. | Size | Name | Setting Range | Setting Unit | Default Setting | Applicable Motors | When Enabled | Classification | Reference | | |
|---------------|--------|--|---|--------------|-----------------|-------------------|--------------|----------------|-----------|--|--|
| Pn007 | 2 | Application Function Selections 7 | 0000h to 105Fh | – | 0000h | All | Immediately | Setup | *1 | | |
| | n.□□XX | Analog Monitor 2 Signal Selection | | | | | | | | | |
| | | 00 | Motor speed (1 V/1,000 min ⁻¹) Motor speed (1 V/1,000 mm/s) | | | | | | | | |
| | | 01 | Speed reference (1 V/1,000 min ⁻¹) Speed reference (1 V/1,000 mm/s) | | | | | | | | |
| | | 02 | Torque reference (1 V/100% rated torque) Force reference (1 V/100% rated force) | | | | | | | | |
| | | 03 | Position deviation (0.05 V/reference unit) | | | | | | | | |
| | | 04 | Position amplifier deviation (after electronic gear) (0.05 V/encoder pulse unit) Position amplifier deviation (after electronic gear) (0.05 V/linear encoder pulse unit) | | | | | | | | |
| | | 05 | Position reference speed (1 V/1,000 min ⁻¹) Position reference speed (1 V/1,000 mm/s) | | | | | | | | |
| | | 06 | Reserved setting (Do not use.) | | | | | | | | |
| | | 07 | Load-motor position deviation (0.01 V/reference unit) | | | | | | | | |
| | | 08 | Positioning completion (positioning completed: 5 V, positioning not completed: 0 V) | | | | | | | | |
| | | 09 | Speed feedforward (1 V/1,000 min ⁻¹) Speed feedforward (1 V/1,000 mm/s) | | | | | | | | |
| | | 0A | Torque feedforward (1 V/100% rated torque) Force feedforward (1 V/100% rated force) | | | | | | | | |
| | | 0B | Active gain (1st gain: 1 V, 2nd gain: 2 V) | | | | | | | | |
| | | 0C | Completion of position reference distribution (completed: 5 V, not completed: 0 V) | | | | | | | | |
| | | 0D | External encoder speed (1 V/1,000 min ⁻¹ : value at the motor shaft) | | | | | | | | |
| | | 0E | Reserved setting (Do not use.) | | | | | | | | |
| | | 0F | Reserved setting (Do not use.) | | | | | | | | |
| | | 10 | Main circuit DC voltage | | | | | | | | |
| | | 11 to 24 | Reserved settings (Do not use.) | | | | | | | | |
| | | 25 | Position deviation after position reference filter (0.05 V/reference unit) | | | | | | | | |
| | | 26 to 5F | Reserved settings (Do not use.) | | | | | | | | |
| | | n.□X□□ | Reserved parameter (Do not change.) | | | | | | | | |
| | | n.X□□□ | Reserved parameter (Do not change.) | | | | | | | | |

Continued on next page.

Continued from previous page.

| Parameter No. | Size | Name | Setting Range | Setting Unit | Default Setting | Applicable Motors | When Enabled | Classification | Reference | |
|---------------|--------|--|--|--|-----------------|-------------------|---------------|----------------|-----------|--|
| Pn008 | 2 | Application Function Selections 8 | 0000h to 7121h | - | 4000h | Rotary | After restart | Setup | *1 | |
| | n.□□□X | | Low Battery Voltage Alarm/Warning Selection | | | | | | | |
| | | | 0 | Output alarm (A.830) for low battery voltage. | | | | | | |
| | | | 1 | Output warning (A.930) for low battery voltage. | | | | | | |
| | n.□□X□ | | Function Selection for Undervoltage | | | | | | | |
| | | | 0 | Do not detect undervoltage. | | | | | | |
| | | | 1 | Detect undervoltage warning and limit torque at host controller. | | | | | | |
| | | | 2 | Detect undervoltage warning and limit torque with Pn424 and Pn425 (i.e., only in SERVOPACK). | | | | | | |
| | n.□X□□ | | Warning Detection Selection | | | | | | | |
| | | | 0 | Detect warnings. | | | | | | |
| | | 1 | Do not detect warnings except for A.971. | | | | | | | |
| n.X□□□ | | Reserved parameter (Do not change.) | | | | | | | | |
| Pn009 | 2 | Application Function Selections 9 | 0000h to 0121h | - | 0010h | All | After restart | Tuning | *1 | |
| | n.□□□X | | Reserved parameter (Do not change.) | | | | | | | |
| | n.□□X□ | | Current Control Mode Selection | | | | | | | |
| | | | 0 | Use current control mode 1. | | | | | | |
| | | | 1 | <ul style="list-style-type: none"> • SERVOPACK Models SGD7S-R70A, -R90A, -1R6A, -2R8A, -5R5A, and -7R6A: Use current control mode 1. • SERVOPACK Models SGD7S-120A, -180A, -200A, -330A, -470A, -550A, -590A, and -780A: Use current control mode 2. | | | | | | |
| | | | 2 | Use current control mode 2. | | | | | | |
| | n.□X□□ | | Speed Detection Method Selection | | | | | | | |
| | | | 0 | Use speed detection 1. | | | | | | |
| | | | 1 | Use speed detection 2. | | | | | | |
| | n.X□□□ | | Reserved parameter (Do not change.) | | | | | | | |

Continued on next page.

Continued from previous page.

| Parameter No. | Size | Name | Setting Range | Setting Unit | Default Setting | Applicable Motors | When Enabled | Classification | Reference | |
|---------------|--|---|--|--------------|-----------------|-------------------|---------------|----------------|-----------|--|
| Pn00A | 2 | Application Function Selections A | 0000h to 1044h | - | 0001h | All | After restart | Setup | *1 | |
| | n.□□□X | Motor Stopping Method for Group 2 Alarms | | | | | | | | |
| | | 0 | Apply the dynamic brake or coast the motor to a stop (use the stopping method set in Pn001 = n.□□□X). | | | | | | | |
| | | 1 | Decelerate the motor to a stop using the torque set in Pn406 as the maximum torque. Use the setting of Pn001 = n.□□□X for the status after stopping. | | | | | | | |
| | | 2 | Decelerate the motor to a stop using the torque set in Pn406 as the maximum torque and then let the motor coast. | | | | | | | |
| | | 3 | Decelerate the motor to a stop using the deceleration time set in Pn30A. Use the setting of Pn001 = n.□□□X for the status after stopping. | | | | | | | |
| | 4 | Decelerate the motor to a stop using the deceleration time set in Pn30A and then let the motor coast. | | | | | | | | |
| | n.□□□□ | Stopping Method for Forced Stops | | | | | | | | |
| | | 0 | Apply the dynamic brake or coast the motor to a stop (use the stopping method set in Pn001 = n.□□□X). | | | | | | | |
| | | 1 | Decelerate the motor to a stop using the torque set in Pn406 as the maximum torque. Use the setting of Pn001 = n.□□□X for the status after stopping. | | | | | | | |
| | | 2 | Decelerate the motor to a stop using the torque set in Pn406 as the maximum torque and then let the motor coast. | | | | | | | |
| | | 3 | Decelerate the motor to a stop using the deceleration time set in Pn30A. Use the setting of Pn001 = n.□□□X for the status after stopping. | | | | | | | |
| | 4 | Decelerate the motor to a stop using the deceleration time set in Pn30A and then let the motor coast. | | | | | | | | |
| | n.□X□□ | Reserved parameter (Do not change.) | | | | | | | | |
| n.X□□□ | Reserved parameter (Do not change.) | | | | | | | | | |
| Pn00B | 2 | Application Function Selections B | 0000h to 1121h | - | 0000h | All | After restart | Setup | *1 | |
| | n.□□□X | Operator Parameter Display Selection | | | | | | | | |
| | | 0 | Display only setup parameters. | | | | | | | |
| | 1 | Display all parameters. | | | | | | | | |
| | n.□□□□ | Motor Stopping Method for Group 2 Alarms | | | | | | | | |
| | | 0 | Stop the motor by setting the speed reference to 0. | | | | | | | |
| | | 1 | Apply the dynamic brake or coast the motor to a stop (use the stopping method set in Pn001 = n.□□□X). | | | | | | | |
| | 2 | Set the stopping method with Pn00A = n.□□□X. | | | | | | | | |
| | n.□X□□ | Power Input Selection for Three-phase SERVOPACK | | | | | | | | |
| | | 0 | Use a three-phase power supply input. | | | | | | | |
| 1 | Use a three-phase power supply input as a single-phase power supply input. | | | | | | | | | |
| n.X□□□ | Reserved parameter (Do not change.) | | | | | | | | | |

Continued on next page.

Continued from previous page.

| Parameter No. | Size | Name | Setting Range | Setting Unit | Default Setting | Applicable Motors | When Enabled | Classification | Reference | | |
|---------------|--------|-------------------------------------|--|--|-----------------|-------------------|---------------|----------------|-------------------|--------|--|
| Pn00C | 2 | Application Function Selections C | 0000h to 0131h | – | 0000h | – | After restart | Setup | *1 | | |
| | n.□□□X | | Function Selection for Test without a Motor | | | | | | Applicable Motors | | |
| | | | 0 | Disable tests without a motor. | | | | | | All | |
| | | | 1 | Enable tests without a motor. | | | | | | | |
| | n.□□X□ | | Encoder Resolution for Tests without a Motor | | | | | | Applicable Motors | | |
| | | | 0 | Use 13 bits. | | | | | | Rotary | |
| | | | 1 | Use 20 bits. | | | | | | | |
| | | | 2 | Use 22 bits. | | | | | | | |
| | | | 3 | Use 24 bits. | | | | | | | |
| | n.□X□□ | | Encoder Type Selection for Tests without a Motor | | | | | | Applicable Motors | | |
| | | 0 | Use an incremental encoder. | | | | | | All | | |
| | | 1 | Use an absolute encoder. | | | | | | | | |
| n.X□□□ | | Reserved parameter (Do not change.) | | | | | | | | | |
| Pn00D | 2 | Application Function Selections D | 0000h to 1001h | – | 0000h | All | After restart | Setup | *1 | | |
| | n.□□□X | | Reserved parameter (Do not change.) | | | | | | | | |
| | n.□□X□ | | Reserved parameter (Do not change.) | | | | | | | | |
| | n.□X□□ | | Reserved parameter (Do not change.) | | | | | | | | |
| | n.X□□□ | | Overtravel Warning Detection Selection | | | | | | | | |
| | | | 0 | Do not detect overtravel warnings. | | | | | | | |
| | | 1 | Detect overtravel warnings. | | | | | | | | |
| Pn00F | 2 | Application Function Selections F | 0000h to 2011h | – | 0000h | All | After restart | Setup | *1 | | |
| | n.□□□X | | Preventative Maintenance Warning Selection | | | | | | | | |
| | | | 0 | Do not detect preventative maintenance warnings. | | | | | | | |
| | | | 1 | Detect preventative maintenance warnings. | | | | | | | |
| | n.□□X□ | | Reserved parameter (Do not change.) | | | | | | | | |
| | n.□X□□ | | Reserved parameter (Do not change.) | | | | | | | | |
| | n.X□□□ | | Reserved parameter (Do not change.) | | | | | | | | |
| Pn021 | 2 | Reserved parameter (Do not change.) | – | – | 0000h | All | – | – | – | | |
| Pn022 | 2 | Reserved parameter (Do not change.) | – | – | 0000h | All | – | – | – | | |

Continued on next page.

Continued from previous page.

| Parameter No. | Size | Name | Setting Range | Setting Unit | Default Setting | Applicable Motors | When Enabled | Classification | Reference | | |
|---------------|--------|---|---|--|-----------------|-------------------|---------------|----------------|-------------------|--------|--|
| Pn040 | 2 | Σ-V Compatible Function Switch | 0000h to 2111h | - | 0000h | - | After restart | Setup | - | | |
| | n.□□□X | | Communications Interface Compatibility Selection | | | | | | Applicable Motors | | |
| | | | 0 | Perform Σ-7 communications. | | | | | | All | |
| | | | 1 | Perform Σ-V communications. | | | | | | | |
| | n.□□X□ | | Encoder Resolution Compatibility Selection | | | | | | Applicable Motors | | |
| | | | 0 | Use the encoder resolution of the Servomotor. | | | | | | Rotary | |
| | | | 1 | Use a resolution of 20 bits when connected to an SGM7J, SGM7A, SGM7P, SGM7G, SGM7E, or SGM7F Servomotor. | | | | | | | |
| n.□X□□ | | Reserved parameter (Do not change.) | | | | | | | | | |
| n.X□□□ | | Reserved parameter (Do not change.) | | | | | | | | | |
| Pn080 | 2 | Application Function Selections 80 | 0000h to 1111h | - | 0000h | Linear | After restart | Setup | *1 | | |
| | n.□□□X | | Polarity Sensor Selection | | | | | | | | |
| | | | 0 | Use polarity sensor. | | | | | | | |
| | | | 1 | Do not use polarity sensor. | | | | | | | |
| | n.□□X□ | | Motor Phase Sequence Selection | | | | | | | | |
| | | | 0 | Set a phase-A lead as a phase sequence of U, V, and W. | | | | | | | |
| | | | 1 | Set a phase-B lead as a phase sequence of U, V, and W. | | | | | | | |
| n.□X□□ | | Reserved parameter (Do not change.) | | | | | | | | | |
| n.X□□□ | | Calculation Method for Maximum Speed or Encoder Output Pulses | | | | | | | | | |
| | | 0 | Calculate the encoder output pulse setting for a fixed maximum speed. | | | | | | | | |
| | | 1 | Calculate the maximum speed for a fixed encoder output pulse setting. | | | | | | | | |
| Pn081 | 2 | Application Function Selections 81 | 0000h to 1111h | - | 0000h | All | After restart | Setup | *1 | | |
| | n.□□□X | | Phase-C Pulse Output Selection | | | | | | | | |
| | | | 0 | Output phase-C pulses only in the forward direction. | | | | | | | |
| | | | 1 | Output phase-C pulses in both the forward and reverse directions. | | | | | | | |
| | n.□□X□ | | Reserved parameter (Do not change.) | | | | | | | | |
| | n.□X□□ | | Reserved parameter (Do not change.) | | | | | | | | |
| n.X□□□ | | Reserved parameter (Do not change.) | | | | | | | | | |
| Pn100 | 2 | Speed Loop Gain | 10 to 20,000 | 0.1 Hz | 400 | All | Immediately | Tuning | *1 | | |
| Pn101 | 2 | Speed Loop Integral Time Constant | 15 to 51,200 | 0.01 ms | 2000 | All | Immediately | Tuning | *1 | | |
| Pn102 | 2 | Position Loop Gain | 10 to 20,000 | 0.1/s | 400 | All | Immediately | Tuning | *1 | | |
| Pn103 | 2 | Moment of Inertia Ratio | 0 to 20,000 | 1% | 100 | All | Immediately | Tuning | *1 | | |
| Pn104 | 2 | Second Speed Loop Gain | 10 to 20,000 | 0.1 Hz | 400 | All | Immediately | Tuning | *1 | | |

Continued on next page.

Continued from previous page.

| Parameter No. | Size | Name | Setting Range | Setting Unit | Default Setting | Applicable Motors | When Enabled | Classification | Reference | |
|---------------|--------|---|----------------------------------|--|-----------------|-------------------|---------------|----------------|---------------------|--|
| Pn105 | 2 | Second Speed Loop Integral Time Constant | 15 to 51,200 | 0.01 ms | 2000 | All | Immediately | Tuning | *1 | |
| Pn106 | 2 | Second Position Loop Gain | 10 to 20,000 | 0.1/s | 400 | All | Immediately | Tuning | *1 | |
| Pn109 | 2 | Feedforward | 0 to 100 | 1% | 0 | All | Immediately | Tuning | *1 | |
| Pn10A | 2 | Feedforward Filter Time Constant | 0 to 6,400 | 0.01 ms | 0 | All | Immediately | Tuning | *1 | |
| Pn10B | 2 | Gain Application Selections | 0000h to 5334h | – | 0004h | All | – | Setup | *1 | |
| | | | Mode Switching Selection | | | | | | When Enabled | |
| | n.□□□X | | 0 | Use the internal torque reference as the condition (level setting: Pn10C). | | | | Immediately | | |
| | | | 1 | Use the speed reference as the condition (level setting: Pn10D). | | | | | | |
| | | | | Use the speed reference as the condition (level setting: Pn181). | | | | | | |
| | | | 2 | Use the acceleration reference as the condition (level setting: Pn10E). | | | | | | |
| | | | | Use the acceleration reference as the condition (level setting: Pn182). | | | | | | |
| | | | 3 | Use the position deviation as the condition (level setting: Pn10F). | | | | | | |
| | | | 4 | Do not use mode switching. | | | | | | |
| | | | Speed Loop Control Method | | | | | | When Enabled | |
| n.□□X□ | | 0 | PI control | | | | After restart | | | |
| | | 1 | I-P control | | | | | | | |
| | | 2 to 3 | Reserved settings (Do not use.) | | | | | | | |
| n.□X□□ | | Reserved parameter (Do not change.) | | | | | | | | |
| n.X□□□ | | Reserved parameter (Do not change.) | | | | | | | | |
| Pn10C | 2 | Mode Switching Level for Torque Reference | 0 to 800 | 1% | 200 | All | Immediately | Tuning | *1 | |
| Pn10D | 2 | Mode Switching Level for Speed Reference | 0 to 10,000 | 1 min ⁻¹ | 0 | Rotary | Immediately | Tuning | *1 | |
| Pn10E | 2 | Mode Switching Level for Acceleration | 0 to 30,000 | 1 min ⁻¹ /s | 0 | Rotary | Immediately | Tuning | *1 | |
| Pn10F | 2 | Mode Switching Level for Position Deviation | 0 to 10,000 | 1 reference unit | 0 | All | Immediately | Tuning | *1 | |
| Pn11F | 2 | Position Integral Time Constant | 0 to 50,000 | 0.1 ms | 0 | All | Immediately | Tuning | *1 | |
| Pn121 | 2 | Friction Compensation Gain | 10 to 1,000 | 1% | 100 | All | Immediately | Tuning | *1 | |
| Pn122 | 2 | Second Friction Compensation Gain | 10 to 1,000 | 1% | 100 | All | Immediately | Tuning | *1 | |
| Pn123 | 2 | Friction Compensation Coefficient | 0 to 100 | 1% | 0 | All | Immediately | Tuning | *1 | |
| Pn124 | 2 | Friction Compensation Frequency Correction | -10,000 to 10,000 | 0.1 Hz | 0 | All | Immediately | Tuning | *1 | |
| Pn125 | 2 | Friction Compensation Gain Correction | 1 to 1,000 | 1% | 100 | All | Immediately | Tuning | *1 | |
| Pn131 | 2 | Gain Switching Time 1 | 0 to 65,535 | 1 ms | 0 | All | Immediately | Tuning | *1 | |
| Pn132 | 2 | Gain Switching Time 2 | 0 to 65,535 | 1 ms | 0 | All | Immediately | Tuning | *1 | |
| Pn135 | 2 | Gain Switching Waiting Time 1 | 0 to 65,535 | 1 ms | 0 | All | Immediately | Tuning | *1 | |
| Pn136 | 2 | Gain Switching Waiting Time 2 | 0 to 65,535 | 1 ms | 0 | All | Immediately | Tuning | *1 | |

Continued on next page.

Continued from previous page.

| Parameter No. | Size | Name | Setting Range | Setting Unit | Default Setting | Applicable Motors | When Enabled | Classification | Reference | |
|---------------|-------------------------------------|---|----------------|---|---|-------------------|--------------|----------------|-----------|--|
| Pn139 | 2 | Automatic Gain Switching Selections 1 | 0000h to 0052h | – | 0000h | All | Immediately | Tuning | *1 | |
| | n.□□□X | Gain Switching Selection | | 0 | Use manual gain switching. The gain is switched manually with G-SEL in the servo command output signals (SVCMD_IO). | | | | | |
| | | 1 | | Reserved setting (Do not use.) | | | | | | |
| | | 2 | | Use automatic gain switching pattern 1. The gain is switched automatically from the first gain to the second gain when switching condition A is satisfied. The gain is switched automatically from the second gain to the first gain when switching condition A is not satisfied. | | | | | | |
| | n.□□X□ | Gain Switching Condition A | | 0 | /COIN (Positioning Completion Output) signal turns ON. | | | | | |
| | | 1 | | /COIN (Positioning Completion Output) signal turns OFF. | | | | | | |
| | | 2 | | /NEAR (Near Output) signal turns ON. | | | | | | |
| | | 3 | | /NEAR (Near Output) signal turns OFF. | | | | | | |
| | | 4 | | Position reference filter output is 0 and position reference input is OFF. | | | | | | |
| | | 5 | | Position reference input is ON. | | | | | | |
| n.□X□□ | Reserved parameter (Do not change.) | | | | | | | | | |
| n.X□□□ | Reserved parameter (Do not change.) | | | | | | | | | |
| Pn13D | 2 | Current Gain Level | 100 to 2,000 | 1% | 2000 | All | Immediately | Tuning | *1 | |
| Pn13F | 2 | Less-Deviation Control 2 Second Position Integral Time Constant | 0 to 50,000 | 0.1 ms | 0 | All | Immediately | Tuning | – | |
| Pn140 | 2 | Model Following Control-Related Selections | 0000h to 1121h | – | 0100h | All | Immediately | Tuning | *1 | |
| | n.□□□X | Model Following Control Selection | | 0 | Do not use model following control. | | | | | |
| | | 1 | | Use model following control. | | | | | | |
| | n.□□X□ | Vibration Suppression Selection | | 0 | Do not perform vibration suppression. | | | | | |
| | | 1 | | Perform vibration suppression for a specific frequency. | | | | | | |
| | | 2 | | Perform vibration suppression for two specific frequencies. | | | | | | |
| | n.□X□□ | Vibration Suppression Adjustment Selection | | 0 | Do not adjust vibration suppression automatically during execution of autotuning without a host reference, autotuning with a host reference, and custom tuning. | | | | | |
| | | 1 | | Adjust vibration suppression automatically during execution of autotuning without a host reference, autotuning with a host reference, and custom tuning. | | | | | | |
| | n.X□□□ | Speed Feedforward (VFF)/Torque Feedforward (TFF) Selection | | 0 | Do not use model following control and speed/torque feedforward together. | | | | | |
| | | 1 | | Use model following control and speed/torque feedforward together. | | | | | | |
| Pn141 | 2 | Model Following Control Gain | 10 to 20,000 | 0.1/s | 500 | All | Immediately | Tuning | *1 | |
| Pn142 | 2 | Model Following Control Gain Correction | 500 to 2,000 | 0.1% | 1000 | All | Immediately | Tuning | *1 | |

Continued on next page.

Continued from previous page.

| Parameter No. | Size | Name | Setting Range | Setting Unit | Default Setting | Applicable Motors | When Enabled | Classification | Reference | |
|---------------|--------|--|---|--|-----------------|-------------------|---------------|----------------|-----------|--|
| Pn143 | 2 | Model Following Control Bias in the Forward Direction | 0 to 10,000 | 0.1% | 1000 | All | Immediately | Tuning | *1 | |
| Pn144 | 2 | Model Following Control Bias in the Reverse Direction | 0 to 10,000 | 0.1% | 1000 | All | Immediately | Tuning | *1 | |
| Pn145 | 2 | Vibration Suppression 1 Frequency A | 10 to 2,500 | 0.1 Hz | 500 | All | Immediately | Tuning | *1 | |
| Pn146 | 2 | Vibration Suppression 1 Frequency B | 10 to 2,500 | 0.1 Hz | 700 | All | Immediately | Tuning | *1 | |
| Pn147 | 2 | Model Following Control Speed Feedforward Compensation | 0 to 10,000 | 0.1% | 1000 | All | Immediately | Tuning | *1 | |
| Pn148 | 2 | Second Model Following Control Gain | 10 to 20,000 | 0.1/s | 500 | All | Immediately | Tuning | *1 | |
| Pn149 | 2 | Second Model Following Control Gain Correction | 500 to 2,000 | 0.1% | 1000 | All | Immediately | Tuning | *1 | |
| Pn14A | 2 | Vibration Suppression 2 Frequency | 10 to 2,000 | 0.1 Hz | 800 | All | Immediately | Tuning | *1 | |
| Pn14B | 2 | Vibration Suppression 2 Correction | 10 to 1,000 | 1% | 100 | All | Immediately | Tuning | *1 | |
| Pn14F | 2 | Control-Related Selections | 0000h to 0021h | - | 0021h | All | After restart | Tuning | *1 | |
| | n.□□□X | | Model Following Control Type Selection | | | | | | | |
| | | | 0 | Use model following control type 1. | | | | | | |
| | | | 1 | Use model following control type 2. | | | | | | |
| | n.□□X□ | | Tuning-less Type Selection | | | | | | | |
| | | | 0 | Use tuning-less type 1. | | | | | | |
| | | 1 | Use tuning-less type 2. | | | | | | | |
| | | 2 | Use tuning-less type 3. | | | | | | | |
| n.□X□□ | | Reserved parameter (Do not change.) | | | | | | | | |
| n.X□□□ | | Reserved parameter (Do not change.) | | | | | | | | |
| Pn160 | 2 | Anti-Resonance Control-Related Selections | 0000h to 0011h | - | 0010h | All | Immediately | Tuning | *1 | |
| | n.□□□X | | Anti-Resonance Control Selection | | | | | | | |
| | | | 0 | Do not use anti-resonance control. | | | | | | |
| | | | 1 | Use anti-resonance control. | | | | | | |
| | n.□□X□ | | Anti-Resonance Control Adjustment Selection | | | | | | | |
| | | | 0 | Do not adjust anti-resonance control automatically during execution of autotuning without a host reference, autotuning with a host reference, and custom tuning. | | | | | | |
| | | 1 | Adjust anti-resonance control automatically during execution of autotuning without a host reference, autotuning with a host reference, and custom tuning. | | | | | | | |
| n.□X□□ | | Reserved parameter (Do not change.) | | | | | | | | |
| n.X□□□ | | Reserved parameter (Do not change.) | | | | | | | | |
| Pn161 | 2 | Anti-Resonance Frequency | 10 to 20,000 | 0.1 Hz | 1000 | All | Immediately | Tuning | *1 | |
| Pn162 | 2 | Anti-Resonance Gain Correction | 1 to 1,000 | 1% | 100 | All | Immediately | Tuning | *1 | |

Continued on next page.

Continued from previous page.

| Parameter No. | Size | Name | Setting Range | Setting Unit | Default Setting | Applicable Motors | When Enabled | Classification | Reference | | |
|---------------|--------|---|--|---|-----------------|-------------------|---------------|----------------|---------------|--|--|
| Pn163 | 2 | Anti-Resonance Damping Gain | 0 to 300 | 1% | 0 | All | Immediately | Tuning | *1 | | |
| Pn164 | 2 | Anti-Resonance Filter Time Constant 1 Correction | -1,000 to 1,000 | 0.01 ms | 0 | All | Immediately | Tuning | *1 | | |
| Pn165 | 2 | Anti-Resonance Filter Time Constant 2 Correction | -1,000 to 1,000 | 0.01 ms | 0 | All | Immediately | Tuning | *1 | | |
| Pn166 | 2 | Anti-Resonance Damping Gain 2 | 0 to 1,000 | 1% | 0 | All | Immediately | Tuning | *1 | | |
| Pn170 | 2 | Tuning-less Function-Related Selections | 0000h to 2711h | - | 1400h | All | - | Setup | *1 | | |
| | n.□□□X | | Tuning-less Selection | | | | | When Enabled | | | |
| | | | 0 | Disable tuning-less function. | | | | | After restart | | |
| | | | 1 | Enable tuning-less function. | | | | | | | |
| | n.□□X□ | | Speed Control Method | | | | | When Enabled | | | |
| | | | 0 | Use for speed control. | | | | | After restart | | |
| | | | 1 | Use for speed control and use host controller for position control. | | | | | | | |
| | n.□X□□ | | Rigidity Level | | | | | When Enabled | | | |
| | | | 0 to 7 | Set the rigidity level. | | | | | Immediately | | |
| | n.X□□□ | | Tuning-less Load Level | | | | | When Enabled | | | |
| | | 0 to 2 | Set the load level for the tuning-less function. | | | | | Immediately | | | |
| Pn181 | 2 | Mode Switching Level for Speed Reference | 0 to 10,000 | 1 mm/s | 0 | Linear | Immediately | Tuning | *1 | | |
| Pn182 | 2 | Mode Switching Level for Acceleration | 0 to 30,000 | 1 mm/s ² | 0 | Linear | Immediately | Tuning | *1 | | |
| Pn190 | 2 | Less-Deviation Control-Related Switches | 0000h to 1101h | - | 0100h | All | After restart | Setup | - | | |
| | n.□□□X | | Less-Deviation Control Selection | | | | | | | | |
| | | | 0 | Do not use less-deviation control. | | | | | | | |
| | | | 1 | Use less-deviation control. | | | | | | | |
| | n.□□X□ | | Reserved parameter (Do not change.) | | | | | | | | |
| | n.□X□□ | | Reserved parameter (Do not change.) | | | | | | | | |
| n.X□□□ | | Speed Feedforward/Torque Feedforward Selection | | | | | | | | | |
| | | 0 | Less-deviation control and speed/torque feedforward are not used together. | | | | | | | | |
| | | 1 | Less-deviation control and speed/torque feedforward are used together. | | | | | | | | |
| Pn191 | 2 | Less-Deviation Control 1 Feedforward Gain | 0 to 10,000 | 0.1% | 1000 | All | Immediately | Tuning | - | | |
| Pn192 | 2 | Less-Deviation Control 1 Second Feedforward Gain | 0 to 10,000 | 0.1% | 1000 | All | Immediately | Tuning | - | | |
| Pn193 | 2 | Less-Deviation Control 1 Feedforward Filter Time Constant | 0 to 65,535 | 0.01 ms | 30 | All | Immediately | Tuning | - | | |

Continued on next page.

5.2 SERVOPACKs with MECHATROLINK-III Communications References

5.2.2 List of Servo Parameters

Continued from previous page.

| Parameter No. | Size | Name | Setting Range | Setting Unit | Default Setting | Applicable Motors | When Enabled | Classification | Reference | |
|---------------|--------|--|--|-----------------------------|-----------------|-------------------|---------------|----------------|-----------|--|
| Pn195 | 2 | Less-Deviation Function Selection Switches | 0000h to 2113h | - | 2102h | All | After restart | Setup | - | |
| | n.□□□X | | Reserved parameter (Do not change.) | | | | | | | |
| | n.□□X□ | | Reserved parameter (Do not change.) | | | | | | | |
| | n.□X□□ | | Reserved parameter (Do not change.) | | | | | | | |
| | n.X□□□ | | Less-Deviation Mode Selection | | | | | | | |
| | | 0 | Use Less-Deviation Control 1 Mode when less-deviation control is enabled. (This mode is compatible with the Σ-V-series EX002.) | | | | | | | |
| | | 1 | Reserved setting (Do not use.) | | | | | | | |
| | | 2 | Use Less-Deviation Control 2 Mode when less-deviation control is enabled. | | | | | | | |
| Pn196 | 2 | Less-Deviation Control 2 Speed Feedforward Gain | 0 to 10,000 | 0.1% | 1000 | All | Immediately | Tuning | - | |
| Pn197 | 2 | Less-Deviation Control 2 Torque Feedforward Filter Time Constant | 0 to 65,535 | 0.01 ms | 50 | All | Immediately | Tuning | - | |
| Pn198 | 2 | Less-Deviation Control 2 Forward Torque Feedforward Gain | 0 to 10,000 | 0.1% | 1000 | All | Immediately | Tuning | - | |
| Pn199 | 2 | Less-Deviation Control 2 Reverse Torque Feedforward Gain | 0 to 10,000 | 0.1% | 1000 | All | Immediately | Tuning | - | |
| Pn19A | 2 | Less-Deviation Control 2 Incomplete Integration Rate | 0 to 10,000 | 0.01% | 10000 | All | Immediately | Tuning | - | |
| Pn19B | 2 | Less-Deviation Control 2 Rotary Servomotor Viscous Friction Compensation Coefficient | 0 to 8,000 | 0.01%/100 min ⁻¹ | 0 | Rotary | Immediately | Tuning | - | |
| Pn19C | 2 | Reserved parameter (Do not change.) | - | - | 0 | All | Immediately | Tuning | - | |
| Pn19D | 2 | Less-Deviation Control 2 Linear Servomotor Viscous Friction Compensation Coefficient | 0 to 8,000 | 0.01%/100 mm/s | 0 | Linear | Immediately | Tuning | - | |
| Pn19E | 2 | Reserved parameter (Do not change.) | - | - | 0 | All | Immediately | Tuning | - | |
| Pn19F | 2 | Less-Deviation Control 2 Torque Feedforward Moving Average Time | 0 to 5,100 | 0.1 ms | 0 | All | Immediately | Tuning | - | |
| Pn1A4 | 2 | Reserved parameter (Do not change.) | - | - | 36 | - | Immediately | Tuning | - | |
| Pn1A5 | 2 | Reserved parameter (Do not change.) | - | - | 0 | - | Immediately | Tuning | - | |
| Pn1AE | 2 | Reserved parameter (Do not change.) | - | - | 0 | - | Immediately | Tuning | - | |
| Pn1AF | 2 | Reserved parameter (Do not change.) | - | - | 0 | - | Immediately | Tuning | - | |
| Pn205 | 2 | Multiturn Limit | 0 to 65,535 | 1 rev | 65535 | Rotary | After restart | Setup | *1 | |

Continued on next page.

Continued from previous page.

| Parameter No. | Size | Name | Setting Range | Setting Unit | Default Setting | Applicable Motors | When Enabled | Classification | Reference | | |
|---------------|--------|--|--|---|-----------------|-------------------|---------------|----------------|-----------|--|--|
| Pn207 | 2 | Position Control Function Selections | 0000h to 2210h | - | 1000h | All | After restart | Setup | *1 | | |
| | n.□□□X | | Reserved parameter (Do not change.) | | | | | | | | |
| | n.□□X□ | | Reserved parameter (Do not change.) | | | | | | | | |
| | n.□X□□ | | Reserved parameter (Do not change.) | | | | | | | | |
| | n.X□□□ | | /COIN (Positioning Completion Output) Signal Output Timing | | | | | | | | |
| | | | 0 | Output when the absolute value of the position deviation is the same or less than the setting of Pn522 (Positioning Completed Width). | | | | | | | |
| | | 1 | Output when the absolute value of the position error is the same or less than the setting of Pn522 (Positioning Completed Width) and the reference after the position reference filter is 0. | | | | | | | | |
| | | 2 | Output when the absolute value of the position error is the same or less than the setting of Pn522 (Positioning Completed Width) and the reference input is 0. | | | | | | | | |
| Pn20A | 4 | Number of External Encoder Scale Pitches | 4 to 1,048,576 | 1 scale pitch/revolution | 32768 | Rotary | After restart | Setup | *1 | | |
| Pn20E | 4 | Electronic Gear Ratio (Numerator) | 1 to 1,073,741,824 | 1 | 16 | All | After restart | Setup | *1 | | |
| Pn210 | 4 | Electronic Gear Ratio (Denominator) | 1 to 1,073,741,824 | 1 | 1 | All | After restart | Setup | *1 | | |
| Pn212 | 4 | Number of Encoder Output Pulses | 16 to 1,073,741,824 | 1 P/Rev | 2048 | Rotary | After restart | Setup | *1 | | |
| Pn22A | 2 | Fully-closed Control Selections | 0000h to 1003h | - | 0000h | Rotary | After restart | Setup | *1 | | |
| | n.□□□X | | Reserved parameter (Do not change.) | | | | | | | | |
| | n.□□X□ | | Reserved parameter (Do not change.) | | | | | | | | |
| | n.□X□□ | | Reserved parameter (Do not change.) | | | | | | | | |
| | n.X□□□ | | Fully-closed Control Speed Feedback Selection | | | | | | | | |
| | | | 0 | Use motor encoder speed. | | | | | | | |
| | | 1 | Use external encoder speed. | | | | | | | | |
| Pn230 | 2 | Position Control Expansion Function Selections | 0000h to 0001h | - | 0000h | All | After restart | Setup | *1 | | |
| | n.□□□X | | Backlash Compensation Direction | | | | | | | | |
| | | | 0 | Compensate forward references. | | | | | | | |
| | | | 1 | Compensate reverse references. | | | | | | | |
| | n.□□X□ | | Reserved parameter (Do not change.) | | | | | | | | |
| | n.□X□□ | | Reserved parameter (Do not change.) | | | | | | | | |
| n.X□□□ | | Reserved parameter (Do not change.) | | | | | | | | | |
| Pn231 | 4 | Backlash Compensation | -500,000 to 500,000 | 0.1 reference units | 0 | All | Immediately | Setup | *1 | | |
| Pn233 | 2 | Backlash Compensation Time Constant | 0 to 65,535 | 0.01 ms | 0 | All | Immediately | Setup | *1 | | |

Continued on next page.

Continued from previous page.

| Parameter No. | Size | Name | Setting Range | Setting Unit | Default Setting | Applicable Motors | When Enabled | Classification | Reference | | |
|---------------|------|---|----------------|--|--|-------------------|---------------|----------------|-----------|--|--|
| Pn234 | 2 | Second Position Reference Acceleration/Deceleration Time Constant | 0 to 65,535 | 0.1 ms | 0 | All | Immediately | Setup | - | | |
| Pn281 | 2 | Encoder Output Resolution | 1 to 4,096 | 1 edge/pitch | 20 | All | After restart | Setup | *1 | | |
| Pn282 | 4 | Linear Encoder Scale Pitch | 0 to 6,553,600 | 0.01 μm | 0 | Linear | After restart | Setup | *1 | | |
| Pn304 | 2 | Jogging Speed | 0 to 10,000 | Rotary: 1 min^{-1} Direct Drive: 0.1 min^{-1} | 500 | Rotary | Immediately | Setup | *1 | | |
| Pn305 | 2 | Soft Start Acceleration Time | 0 to 10,000 | 1 ms | 0 | All | Immediately | Setup | *2 | | |
| Pn306 | 2 | Soft Start Deceleration Time | 0 to 10,000 | 1 ms | 0 | All | Immediately | Setup | *2 | | |
| Pn308 | 2 | Speed Feedback Filter Time Constant | 0 to 65,535 | 0.01 ms | 0 | All | Immediately | Setup | *1 | | |
| Pn30A | 2 | Deceleration Time for Servo OFF and Forced Stops | 0 to 10,000 | 1 ms | 0 | All | Immediately | Setup | *1 | | |
| Pn30C | 2 | Speed Feedforward Average Movement Time | 0 to 5,100 | 0.1 ms | 0 | All | Immediately | Setup | *1 | | |
| Pn310 | 2 | Vibration Detection Selections | 0000h to 0002h | - | 0000h | All | Immediately | Setup | *1 | | |
| | | n.□□□X | | Vibration Detection Selection | | | | | | | |
| | | | | 0 | Do not detect vibration. | | | | | | |
| | | | | 1 | Output a warning (A.911) if vibration is detected. | | | | | | |
| | | | | 2 | Output an alarm (A.520) if vibration is detected. | | | | | | |
| | | n.□□X□ | | Reserved parameter (Do not change.) | | | | | | | |
| n.□X□□ | | Reserved parameter (Do not change.) | | | | | | | | | |
| n.X□□□ | | Reserved parameter (Do not change.) | | | | | | | | | |
| Pn311 | 2 | Vibration Detection Sensitivity | 50 to 500 | 1% | 100 | All | Immediately | Tuning | *1 | | |
| Pn312 | 2 | Vibration Detection Level | 0 to 5,000 | 1 min^{-1} | 50 | Rotary | Immediately | Tuning | *1 | | |
| Pn316 | 2 | Maximum Motor Speed | 0 to 65,535 | 1 min^{-1} | 10000 | Rotary | After restart | Setup | *1 | | |
| Pn324 | 2 | Moment of Inertia Calculation Starting Level | 0 to 20,000 | 1% | 300 | All | Immediately | Setup | *1 | | |
| Pn383 | 2 | Jogging Speed | 0 to 10,000 | 1 mm/s | 50 | Linear | Immediately | Setup | *1 | | |
| Pn384 | 2 | Vibration Detection Level | 0 to 5,000 | 1 mm/s | 10 | Linear | Immediately | Tuning | *1 | | |
| Pn385 | 2 | Maximum Motor Speed | 1 to 100 | 100 mm/s | 50 | Linear | After restart | Setup | *1 | | |
| Pn401 | 2 | First Stage First Torque Reference Filter Time Constant | 0 to 65,535 | 0.01 ms | 100 | All | Immediately | Tuning | *1 | | |
| Pn402 | 2 | Forward Torque Limit | 0 to 800 | 1% ^{*3} | 800 | Rotary | Immediately | Setup | *1 | | |
| Pn403 | 2 | Reverse Torque Limit | 0 to 800 | 1% ^{*3} | 800 | Rotary | Immediately | Setup | *1 | | |
| Pn404 | 2 | Forward External Torque Limit | 0 to 800 | 1% ^{*3} | 100 | All | Immediately | Setup | *1 | | |

Continued on next page.

Continued from previous page.

| Parameter No. | Size | Name | Setting Range | Setting Unit | Default Setting | Applicable Motors | When Enabled | Classification | Reference | | |
|---------------|------|--|--------------------------------|--------------------------|---|-------------------|--------------|----------------|--------------|---------------|--|
| Pn405 | 2 | Reverse External Torque Limit | 0 to 800 | 1%*3 | 100 | All | Immediately | Setup | *1 | | |
| Pn406 | 2 | Emergency Stop Torque | 0 to 800 | 1%*3 | 800 | All | Immediately | Setup | *1 | | |
| Pn407 | 2 | Speed Limit during Torque Control | 0 to 10,000 | 1 min ⁻¹ | 10000 | Rotary | Immediately | Setup | *1 | | |
| Pn408 | 2 | Torque-Related Function Selections | | 0000h to 1111h | – | 0000h | All | – | Setup | *1 | |
| | | n.□□□X | | Notch Filter Selection 1 | | | | | When Enabled | | |
| | | | | 0 | Disable first stage notch filter. | | | | | Immediately | |
| | | | | 1 | Enable first stage notch filter. | | | | | | |
| | | n.□□X□ | | Speed Limit Selection | | | | | When Enabled | | |
| | | | | 0 | Use the smaller of the maximum motor speed and the setting of Pn407 as the speed limit. | | | | | After restart | |
| | | | | | Use the smaller of the maximum motor speed and the setting of Pn480 as the speed limit. | | | | | | |
| | | | | 1 | Use the smaller of the overspeed alarm detection speed and the setting of Pn407 as the speed limit. | | | | | | |
| | | | | | Use the smaller of the overspeed alarm detection speed and the setting of Pn480 as the speed limit. | | | | | | |
| | | n.□X□□ | | Notch Filter Selection 2 | | | | | When Enabled | | |
| | | | | 0 | Disable second stage notch filter. | | | | | Immediately | |
| | | | | 1 | Enable second stage notch filter. | | | | | | |
| n.X□□□ | | Friction Compensation Function Selection | | | | | When Enabled | | | | |
| | | 0 | Disable friction compensation. | | | | | Immediately | | | |
| | | 1 | Enable friction compensation. | | | | | | | | |
| Pn409 | 2 | First Stage Notch Filter Frequency | 50 to 5,000 | 1 Hz | 5000 | All | Immediately | Tuning | *1 | | |
| Pn40A | 2 | First Stage Notch Filter Q Value | 50 to 1,000 | 0.01 | 70 | All | Immediately | Tuning | *1 | | |
| Pn40B | 2 | First Stage Notch Filter Depth | 0 to 1,000 | 0.001 | 0 | All | Immediately | Tuning | *1 | | |
| Pn40C | 2 | Second Stage Notch Filter Frequency | 50 to 5,000 | 1 Hz | 5000 | All | Immediately | Tuning | *1 | | |
| Pn40D | 2 | Second Stage Notch Filter Q Value | 50 to 1,000 | 0.01 | 70 | All | Immediately | Tuning | *1 | | |
| Pn40E | 2 | Second Stage Notch Filter Depth | 0 to 1,000 | 0.001 | 0 | All | Immediately | Tuning | *1 | | |
| Pn40F | 2 | Second Stage Second Torque Reference Filter Frequency | 100 to 5,000 | 1 Hz | 5000 | All | Immediately | Tuning | *1 | | |
| Pn410 | 2 | Second Stage Second Torque Reference Filter Q Value | 50 to 100 | 0.01 | 50 | All | Immediately | Tuning | *1 | | |
| Pn412 | 2 | First Stage Second Torque Reference Filter Time Constant | 0 to 65,535 | 0.01 ms | 100 | All | Immediately | Tuning | *1 | | |

Continued on next page.

Continued from previous page.

| Parameter No. | Size | Name | Setting Range | Setting Unit | Default Setting | Applicable Motors | When Enabled | Classification | Reference | |
|---------------|--------|---|---|------------------------------------|-----------------|-------------------|---------------------|---------------------|---------------|--|
| Pn416 | 2 | Torque-Related Function Selections 2 | 0000h to 1111h | - | 0000h | All | Immediately | Setup | *1 | |
| | n.□□□X | | Notch Filter Selection 3 | | | | | | | |
| | | | 0 | Disable third stage notch filter. | | | | | | |
| | | | 1 | Enable third stage notch filter. | | | | | | |
| | n.□□X□ | | Notch Filter Selection 4 | | | | | | | |
| | | | 0 | Disable fourth stage notch filter. | | | | | | |
| | | | 1 | Enable fourth stage notch filter. | | | | | | |
| | n.□X□□ | | Notch Filter Selection 5 | | | | | | | |
| | | | 0 | Disable fifth stage notch filter. | | | | | | |
| | | | 1 | Enable fifth stage notch filter. | | | | | | |
| n.X□□□ | | Reserved parameter (Do not change.) | | | | | | | | |
| Pn417 | 2 | Third Stage Notch Filter Frequency | 50 to 5,000 | 1 Hz | 5000 | All | Immediately | Tuning | *1 | |
| Pn418 | 2 | Third Stage Notch Filter Q Value | 50 to 1,000 | 0.01 | 70 | All | Immediately | Tuning | *1 | |
| Pn419 | 2 | Third Stage Notch Filter Depth | 0 to 1,000 | 0.001 | 0 | All | Immediately | Tuning | *1 | |
| Pn41A | 2 | Fourth Stage Notch Filter Frequency | 50 to 5,000 | 1 Hz | 5000 | All | Immediately | Tuning | *1 | |
| Pn41B | 2 | Fourth Stage Notch Filter Q Value | 50 to 1,000 | 0.01 | 70 | All | Immediately | Tuning | *1 | |
| Pn41C | 2 | Fourth Stage Notch Filter Depth | 0 to 1,000 | 0.001 | 0 | All | Immediately | Tuning | *1 | |
| Pn41D | 2 | Fifth Stage Notch Filter Frequency | 50 to 5,000 | 1 Hz | 5000 | All | Immediately | Tuning | *1 | |
| Pn41E | 2 | Fifth Stage Notch Filter Q Value | 50 to 1,000 | 0.01 | 70 | All | Immediately | Tuning | *1 | |
| Pn41F | 2 | Fifth Stage Notch Filter Depth | 0 to 1,000 | 0.001 | 0 | All | Immediately | Tuning | *1 | |
| Pn423 | 2 | Speed Ripple Compensation Selections | 0000h to 1111h | - | 0000h | Rotary | - | Setup | *1 | |
| | n.□□□X | | Speed Ripple Compensation Function Selection | | | | | When Enabled | | |
| | | | 0 | Disable speed ripple compensation. | | | | | Immediately | |
| | | | 1 | Enable speed ripple compensation. | | | | | | |
| | n.□□X□ | | Speed Ripple Compensation Information Disagreement Warning Detection Selection | | | | | When Enabled | | |
| | | | 0 | Detect A.942 alarms. | | | | | After restart | |
| | | 1 | Do not detect A.942 alarms. | | | | | | | |
| n.□X□□ | | Speed Ripple Compensation Enable Condition Selection | | | | | When Enabled | | | |
| | | 0 | Speed reference | | | | | After restart | | |
| | | 1 | Motor speed | | | | | | | |
| n.X□□□ | | Reserved parameter (Do not change.) | | | | | | | | |
| Pn424 | 2 | Torque Limit at Main Circuit Voltage Drop | 0 to 100 | 1%*2 | 50 | All | Immediately | Setup | *1 | |

Continued on next page.

Continued from previous page.

| Parameter No. | Size | Name | Setting Range | Setting Unit | Default Setting | Applicable Motors | When Enabled | Classification | Reference | | |
|---------------|-------------------------------------|--|-------------------------------------|---|-----------------|-------------------|--------------|----------------|-----------|----|--|
| Pn425 | 2 | Release Time for Torque Limit at Main Circuit Voltage Drop | 0 to 1,000 | 1 ms | 100 | All | Immediately | Setup | *1 | | |
| Pn426 | 2 | Torque Feedforward Average Movement Time | 0 to 5,100 | 0.1 ms | 0 | All | Immediately | Setup | *1 | | |
| Pn427 | 2 | Speed Ripple Compensation Enable Speed | 0 to 10,000 | 1 min ⁻¹ | 0 | Rotary Servomotor | Immediately | Tuning | *1 | | |
| Pn456 | 2 | Sweep Torque Reference Amplitude | 1 to 800 | 1% | 15 | All | Immediately | Tuning | *1 | | |
| Pn460 | 2 | Notch Filter Adjustment Selections 1 | | 0000h to 0101h | - | 0101h | All | Immediately | Tuning | *1 | |
| | | n.□□□X | Notch Filter Adjustment Selection 1 | | | | | | | | |
| | | | 0 | Do not adjust the first stage notch filter automatically during execution of autotuning without a host reference, autotuning with a host reference, and custom tuning. | | | | | | | |
| | | | 1 | Adjust the first stage notch filter automatically during execution of autotuning without a host reference, autotuning with a host reference, and custom tuning. | | | | | | | |
| | | n.□□X□ | Reserved parameter (Do not change.) | | | | | | | | |
| | | n.□X□□ | Notch Filter Adjustment Selection 2 | | | | | | | | |
| | | | 0 | Do not adjust the second stage notch filter automatically when the tuning-less function is enabled or during execution of autotuning without a host reference, autotuning with a host reference, and custom tuning. | | | | | | | |
| | 1 | Adjust the second stage notch filter automatically when the tuning-less function is enabled or during execution of autotuning without a host reference, autotuning with a host reference, and custom tuning. | | | | | | | | | |
| n.X□□□ | Reserved parameter (Do not change.) | | | | | | | | | | |
| Pn475 | 2 | Gravity Compensation-Related Selections | | 0000h to 0001h | - | 0000h | All | After restart | Setup | *1 | |
| | | n.□□□X | Gravity Compensation Selection | | | | | | | | |
| | | | 0 | Disable gravity compensation. | | | | | | | |
| | | | 1 | Enable gravity compensation. | | | | | | | |
| | | n.□□X□ | Reserved parameter (Do not change.) | | | | | | | | |
| | | n.□X□□ | Reserved parameter (Do not change.) | | | | | | | | |
| | | n.X□□□ | Reserved parameter (Do not change.) | | | | | | | | |
| Pn476 | 2 | Gravity Compensation Torque | -1,000 to 1,000 | 0.1% | 0 | All | Immediately | Tuning | *1 | | |
| Pn480 | 2 | Speed Limit during Force Control | 0 to 10,000 | 1 mm/s | 10000 | Linear | Immediately | Setup | *1 | | |
| Pn481 | 2 | Polarity Detection Speed Loop Gain | 10 to 20,000 | 0.1 Hz | 400 | Linear | Immediately | Tuning | - | | |
| Pn482 | 2 | Polarity Detection Speed Loop Integral Time Constant | 15 to 51,200 | 0.01 ms | 3000 | Linear | Immediately | Tuning | - | | |
| Pn483 | 2 | Forward Force Limit | 0 to 800 | 1%*3 | 30 | Linear | Immediately | Setup | *1 | | |
| Pn484 | 2 | Reverse Force Limit | 0 to 800 | 1%*3 | 30 | Linear | Immediately | Setup | *1 | | |
| Pn485 | 2 | Polarity Detection Reference Speed | 0 to 100 | 1 mm/s | 20 | Linear | Immediately | Tuning | - | | |
| Pn486 | 2 | Polarity Detection Reference Acceleration/Deceleration Time | 0 to 100 | 1 ms | 25 | Linear | Immediately | Tuning | - | | |

Continued on next page.

5.2 SERVOPACKs with MECHATROLINK-III Communications References

5.2.2 List of Servo Parameters

Continued from previous page.

| Parameter No. | Size | Name | Setting Range | Setting Unit | Default Setting | Applicable Motors | When Enabled | Classification | Reference | |
|---------------|------|--|---|---|-----------------|-------------------|---------------|----------------|-----------|--|
| Pn487 | 2 | Polarity Detection Constant Speed Time | 0 to 300 | 1 ms | 0 | Linear | Immediately | Tuning | - | |
| Pn488 | 2 | Polarity Detection Reference Waiting Time | 50 to 500 | 1 ms | 100 | Linear | Immediately | Tuning | - | |
| Pn48E | 2 | Polarity Detection Range | 1 to 65,535 | 1 mm | 10 | Linear | Immediately | Tuning | - | |
| Pn490 | 2 | Polarity Detection Load Level | 0 to 20,000 | 1% | 100 | Linear | Immediately | Tuning | - | |
| Pn495 | 2 | Polarity Detection Confirmation Force Reference | 0 to 200 | 1% | 100 | Linear | Immediately | Tuning | - | |
| Pn498 | 2 | Polarity Detection Allowable Error Range | 0 to 30 | 1 deg | 10 | Linear | Immediately | Tuning | - | |
| Pn49F | 2 | Speed Ripple Compensation Enable Speed | 0 to 10,000 | 1 mm/s | 0 | Linear | Immediately | Tuning | *1 | |
| Pn502 | 2 | Rotation Detection Level | 1 to 10,000 | 1 min ⁻¹ | 20 | Rotary | Immediately | Setup | *1 | |
| Pn503 | 2 | Speed Coincidence Detection Signal Output Width | 0 to 100 | 1 min ⁻¹ | 10 | Rotary | Immediately | Setup | *1 | |
| Pn506 | 2 | Brake Reference-Servo OFF Delay Time | 0 to 50 | 10 ms | 0 | All | Immediately | Setup | *1 | |
| Pn507 | 2 | Brake Reference Output Speed Level | 0 to 10,000 | 1 min ⁻¹ | 100 | Rotary | Immediately | Setup | *1 | |
| Pn508 | 2 | Servo OFF-Brake Command Waiting Time | 10 to 100 | 10 ms | 50 | All | Immediately | Setup | *1 | |
| Pn509 | 2 | Momentary Power Interruption Hold Time | 20 to 50,000 | 1 ms | 20 | All | Immediately | Setup | *1 | |
| Pn50A | 2 | Input Signal Selections 1 | 0000h to FFF2h | - | 1881h | All | After restart | Setup | *1 | |
| | | n.□□□X | Reserved parameter (Do not change.) | | | | | | | |
| | | n.□□X□ | Reserved parameter (Do not change.) | | | | | | | |
| | | n.□X□□ | Reserved parameter (Do not change.) | | | | | | | |
| | | n.X□□□ | P-OT (Forward Drive Prohibit) Signal Allocation | | | | | | | |
| | | | 0 | Enable forward drive when CN1-13 input signal is ON (closed). | | | | | | |
| | | | 1 | Enable forward drive when CN1-7 input signal is ON (closed). | | | | | | |
| | | | 2 | Enable forward drive when CN1-8 input signal is ON (closed). | | | | | | |
| | | | 3 | Enable forward drive when CN1-9 input signal is ON (closed). | | | | | | |
| | | | 4 | Enable forward drive when CN1-10 input signal is ON (closed). | | | | | | |
| | | | 5 | Enable forward drive when CN1-11 input signal is ON (closed). | | | | | | |
| | | | 6 | Enable forward drive when CN1-12 input signal is ON (closed). | | | | | | |
| | | | 7 | Set the signal to always prohibit forward drive. | | | | | | |
| | | | 8 | Set the signal to always enable forward drive. | | | | | | |
| | | | 9 | Enable forward drive when CN1-13 input signal is OFF (open). | | | | | | |
| | A | | Enable forward drive when CN1-7 input signal is OFF (open). | | | | | | | |
| | B | | Enable forward drive when CN1-8 input signal is OFF (open). | | | | | | | |
| | C | | Enable forward drive when CN1-9 input signal is OFF (open). | | | | | | | |
| | D | Enable forward drive when CN1-10 input signal is OFF (open). | | | | | | | | |
| | E | Enable forward drive when CN1-11 input signal is OFF (open). | | | | | | | | |
| | F | Enable forward drive when CN1-12 input signal is OFF (open). | | | | | | | | |

Continued on next page.

Continued from previous page.

| Parameter No. | Size | Name | Setting Range | Setting Unit | Default Setting | Applicable Motors | When Enabled | Classification | Reference | |
|---------------|--|--------------------------------------|-------------------------------------|---|-----------------|-------------------|---------------|----------------|-----------|--|
| Pn50B | 2 | Input Signal Selections ² | 0000h to FFFFh | – | 8882h | All | After restart | Setup | *1 | |
| | N-OT (Reverse Drive Prohibit) Signal Allocation | | | | | | | | | |
| | n.□□□X | | 0 | Enable reverse drive when CN1-13 input signal is ON (closed). | | | | | | |
| | n.□□□X | | 1 | Enable reverse drive when CN1-7 input signal is ON (closed). | | | | | | |
| | n.□□□X | | 2 | Enable reverse drive when CN1-8 input signal is ON (closed). | | | | | | |
| | n.□□□X | | 3 | Enable reverse drive when CN1-9 input signal is ON (closed). | | | | | | |
| | n.□□□X | | 4 | Enable reverse drive when CN1-10 input signal is ON (closed). | | | | | | |
| | n.□□□X | | 5 | Enable reverse drive when CN1-11 input signal is ON (closed). | | | | | | |
| | n.□□□X | | 6 | Enable reverse drive when CN1-12 input signal is ON (closed). | | | | | | |
| | n.□□□X | | 7 | Set the signal to always prohibit reverse drive. | | | | | | |
| | n.□□□X | | 8 | Set the signal to always enable reverse drive. | | | | | | |
| | n.□□□X | | 9 | Enable reverse drive when CN1-13 input signal is OFF (open). | | | | | | |
| | n.□□□X | | A | Enable reverse drive when CN1-7 input signal is OFF (open). | | | | | | |
| | n.□□□X | | B | Enable reverse drive when CN1-8 input signal is OFF (open). | | | | | | |
| | n.□□□X | | C | Enable reverse drive when CN1-9 input signal is OFF (open). | | | | | | |
| | n.□□□X | | D | Enable reverse drive when CN1-10 input signal is OFF (open). | | | | | | |
| | n.□□□X | | E | Enable reverse drive when CN1-11 input signal is OFF (open). | | | | | | |
| | n.□□□X | | F | Enable reverse drive when CN1-12 input signal is OFF (open). | | | | | | |
| | n.□□□□ | | Reserved parameter (Do not change.) | | | | | | | |
| | /P-CL (Forward External Torque Limit Input) Signal Allocation | | | | | | | | | |
| | n.□X□□ | | 0 | Active when CN1-13 input signal is ON (closed). | | | | | | |
| | n.□X□□ | | 1 | Active when CN1-7 input signal is ON (closed). | | | | | | |
| | n.□X□□ | | 2 | Active when CN1-8 input signal is ON (closed). | | | | | | |
| | n.□X□□ | | 3 | Active when CN1-9 input signal is ON (closed). | | | | | | |
| | n.□X□□ | | 4 | Active when CN1-10 input signal is ON (closed). | | | | | | |
| | n.□X□□ | | 5 | Active when CN1-11 input signal is ON (closed). | | | | | | |
| | n.□X□□ | | 6 | Active when CN1-12 input signal is ON (closed). | | | | | | |
| | n.□X□□ | | 7 | The signal is always active. | | | | | | |
| | n.□X□□ | | 8 | The signal is always inactive. | | | | | | |
| | n.□X□□ | | 9 | Active when CN1-13 input signal is OFF (open). | | | | | | |
| | n.□X□□ | | A | Active when CN1-7 input signal is OFF (open). | | | | | | |
| | n.□X□□ | | B | Active when CN1-8 input signal is OFF (open). | | | | | | |
| | n.□X□□ | | C | Active when CN1-9 input signal is OFF (open). | | | | | | |
| | n.□X□□ | | D | Active when CN1-10 input signal is OFF (open). | | | | | | |
| | n.□X□□ | | E | Active when CN1-11 input signal is OFF (open). | | | | | | |
| | n.□X□□ | | F | Active when CN1-12 input signal is OFF (open). | | | | | | |
| | /N-CL (Reverse External Torque Limit Input) Signal Allocation | | | | | | | | | |
| | n.X□□□ | | 0 to F | The allocations are the same as the /P-CL (Forward External Torque Limit Input) signal allocations. | | | | | | |

Continued on next page.

Continued from previous page.

| Parameter No. | Size | Name | Setting Range | Setting Unit | Default Setting | Applicable Motors | When Enabled | Classification | Reference | | |
|---------------|--------|--|--|---|-----------------|-------------------|---------------|----------------|-----------|----|--|
| Pn50E | 2 | Output Signal Selections 1 | 0000h to 6666h | – | 0000h | All | After restart | Setup | *1 | | |
| | n.□□□X | /COIN (Positioning Completion Output) Signal Allocation | | | | | | | | | |
| | | 0 | Disabled (the above signal output is not used). | | | | | | | | |
| | | 1 | Output the signal from the CN1-1 or CN1-2 output terminal. | | | | | | | | |
| | | 2 | Output the signal from the CN1-23 or CN1-24 output terminal. | | | | | | | | |
| | | 3 | Output the signal from the CN1-25 or CN1-26 output terminal. | | | | | | | | |
| | 4 to 6 | Reserved setting (Do not use.) | | | | | | | | | |
| | n.□□X□ | /V-CMP (Speed Coincidence Detection Output) Signal Allocation | | | | | | | | | |
| | | 0 to 6 | The allocations are the same as the /COIN (Positioning Completion) signal allocations. | | | | | | | | |
| | n.□X□□ | /TGON (Rotation Detection Output) Signal Allocation | | | | | | | | | |
| | | 0 to 6 | The allocations are the same as the /COIN (Positioning Completion) signal allocations. | | | | | | | | |
| | n.X□□□ | /S-RDY (Servo Ready) Signal Allocation | | | | | | | | | |
| | | 0 to 6 | The allocations are the same as the /COIN (Positioning Completion) signal allocations. | | | | | | | | |
| | Pn50F | 2 | Output Signal Selections 2 | 0000h to 6666h | – | 0100h | All | After restart | Setup | *1 | |
| | | n.□□□X | /CLT (Torque Limit Detection Output) Signal Allocation | | | | | | | | |
| | | | 0 | Disabled (the above signal output is not used). | | | | | | | |
| 1 | | | Output the signal from the CN1-1 or CN1-2 output terminal. | | | | | | | | |
| 2 | | | Output the signal from the CN1-23 or CN1-24 output terminal. | | | | | | | | |
| 3 | | | Output the signal from the CN1-25 or CN1-26 output terminal. | | | | | | | | |
| 4 to 6 | | Reserved setting (Do not use.) | | | | | | | | | |
| n.□□X□ | | /VLT (Speed Limit Detection) Signal Allocation | | | | | | | | | |
| | | 0 to 6 | The allocations are the same as the /CLT (Torque Limit Detection Output) signal allocations. | | | | | | | | |
| n.□X□□ | | /BK (Brake Output) Signal Allocation | | | | | | | | | |
| | | 0 to 6 | The allocations are the same as the /CLT (Torque Limit Detection Output) signal allocations. | | | | | | | | |
| n.X□□□ | | /WARN (Warning Output) Signal Allocation | | | | | | | | | |
| | | 0 to 6 | The allocations are the same as the /CLT (Torque Limit Detection Output) signal allocations. | | | | | | | | |

Continued on next page.

Continued from previous page.

| Parameter No. | Size | Name | Setting Range | Setting Unit | Default Setting | Applicable Motors | When Enabled | Classification | Reference | |
|---------------|--------|---|--|--|-----------------|-------------------|---------------|----------------|-----------|--|
| Pn510 | 2 | Output Signal Selections 3 | 0000h to 0666h | - | 0000h | All | After restart | Setup | *1 | |
| | | | /NEAR (Near Output) Signal Allocation | | | | | | | |
| | n.□□□X | | 0 | Disabled (the above signal output is not used). | | | | | | |
| | | | 1 | Output the signal from the CN1-1 or CN1-2 output terminal. | | | | | | |
| | | | 2 | Output the signal from the CN1-23 or CN1-24 output terminal. | | | | | | |
| | | | 3 | Output the signal from the CN1-25 or CN1-26 output terminal. | | | | | | |
| | | | 4 to 6 | Reserved setting (Do not use.) | | | | | | |
| | n.□□X□ | | Reserved parameter (Do not change.) | | | | | | | |
| | n.□X□□ | | Reserved parameter (Do not change.) | | | | | | | |
| | n.X□□□ | | Reserved parameter (Do not change.) | | | | | | | |
| Pn511 | 2 | Input Signal Selections 5 | 0000h to FFFFh | - | 6543h | All | After restart | Setup | *1 | |
| | | | /DEC (Origin Return Deceleration Switch Input) Signal Allocation | | | | | | | |
| | n.□□□X | | 0 | Active when CN1-13 input signal is ON (closed). | | | | | | |
| | | | 1 | Active when CN1-7 input signal is ON (closed). | | | | | | |
| | | | 2 | Active when CN1-8 input signal is ON (closed). | | | | | | |
| | | | 3 | Active when CN1-9 input signal is ON (closed). | | | | | | |
| | | | 4 | Active when CN1-10 input signal is ON (closed). | | | | | | |
| | | | 5 | Active when CN1-11 input signal is ON (closed). | | | | | | |
| | | | 6 | Active when CN1-12 input signal is ON (closed). | | | | | | |
| | | | 7 | The signal is always active. | | | | | | |
| | | | 8 | The signal is always inactive. | | | | | | |
| | | | 9 | Active when CN1-13 input signal is OFF (open). | | | | | | |
| | | | A | Active when CN1-7 input signal is OFF (open). | | | | | | |
| | | | B | Active when CN1-8 input signal is OFF (open). | | | | | | |
| | | | C | Active when CN1-9 input signal is OFF (open). | | | | | | |
| | | | D | Active when CN1-10 input signal is OFF (open). | | | | | | |
| | | | E | Active when CN1-11 input signal is OFF (open). | | | | | | |
| | | | F | Active when CN1-12 input signal is OFF (open). | | | | | | |
| | | | /EXT1 (External Latch Input 1) Signal Allocation | | | | | | | |
| | n.□□X□ | | 0 to 3 | The signal is always inactive. | | | | | | |
| | | | 4 | Active when CN1-10 input signal is ON (closed). | | | | | | |
| | | | 5 | Active when CN1-11 input signal is ON (closed). | | | | | | |
| | | | 6 | Active when CN1-12 input signal is ON (closed). | | | | | | |
| | | | D | Active when CN1-10 input signal is OFF (open). | | | | | | |
| | | | E | Active when CN1-11 input signal is OFF (open). | | | | | | |
| | | | F | Active when CN1-12 input signal is OFF (open). | | | | | | |
| | | | 7 to C | The signal is always inactive. | | | | | | |
| | | | /EXT2 (External Latch Input 2) Signal Allocation | | | | | | | |
| n.□X□□ | | 0 to F | The allocations are the same as the /EXT1 (External Latch Input 1) signal allocations. | | | | | | | |
| | | /EXT3 (External Latch Input 3) Signal Allocation | | | | | | | | |
| n.X□□□ | | 0 to F | The allocations are the same as the /EXT1 (External Latch Input 1) signal allocations. | | | | | | | |

Continued on next page.

Continued from previous page.

| Parameter No. | Size | Name | Setting Range | Setting Unit | Default Setting | Applicable Motors | When Enabled | Classification | Reference | |
|---------------|--------|-------------------------------------|---|--|-----------------|-------------------|---------------|----------------|-----------|--|
| Pn512 | 2 | Output Signal Inverse Settings | 0000h to 1111h | – | 0000h | All | After restart | Setup | *1 | |
| | n.□□□X | | Output Signal Inversion for CN1-1 and CN1-2 Terminals | | | | | | | |
| | | | 0 | The signal is not inverted. | | | | | | |
| | | | 1 | The signal is inverted. | | | | | | |
| | n.□□□□ | | Output Signal Inversion for CN1-23 and CN1-24 Terminals | | | | | | | |
| | | | 0 | The signal is not inverted. | | | | | | |
| | | | 1 | The signal is inverted. | | | | | | |
| | n.□X□□ | | Output Signal Inversion for CN1-25 and CN1-26 Terminals | | | | | | | |
| | | | 0 | The signal is not inverted. | | | | | | |
| | | | 1 | The signal is inverted. | | | | | | |
| n.X□□□ | | Reserved parameter (Do not change.) | | | | | | | | |
| Pn514 | 2 | Output Signal Selections 4 | 0000h to 0666h | – | 0000h | All | After restart | Setup | *1 | |
| | n.□□□X | | Reserved parameter (Do not change.) | | | | | | | |
| | n.□□□□ | | Reserved parameter (Do not change.) | | | | | | | |
| | n.□X□□ | | /PM (Preventative Maintenance Output) Signal Allocation | | | | | | | |
| | | | 0 | Disabled (the above signal output is not used). | | | | | | |
| | | | 1 | Output the signal from the CN1-1 or CN1-2 output terminal. | | | | | | |
| | | | 2 | Output the signal from the CN1-23 or CN1-24 output terminal. | | | | | | |
| | | | 3 | Output the signal from the CN1-25 or CN1-26 output terminal. | | | | | | |
| | | | 4 to 6 | Reserved setting (Do not use.) | | | | | | |
| | n.X□□□ | | Reserved parameter (Do not change.) | | | | | | | |

Continued on next page.

Continued from previous page.

| Parameter No. | Size | Name | Setting Range | Setting Unit | Default Setting | Applicable Motors | When Enabled | Classification | Reference | | | | | | | | | | | | | | | | | | | | | | | | | | | | | | | | | | | | | | | | | |
|---------------|--|---|--------------------|---------------------|-----------------|-------------------|---------------|----------------|-----------|--|--|--|---|---|---|--|---|--|---|--|---|---|---|---|---|---|---|---|---|---|---|--|---|---|---|---|---|---|---|--|---|--|---|--|--------|-------------------------------------|--------|-------------------------------------|--------|-------------------------------------|
| Pn516 | 2 | Input Signal Selections | 0000h to FFFFh | - | 8888h | All | After restart | Setup | *1 | | | | | | | | | | | | | | | | | | | | | | | | | | | | | | | | | | | | | | | | | |
| | <table border="1"> <thead> <tr> <th colspan="2">FSTP (Forced Stop Input) Signal Allocation</th> </tr> </thead> <tbody> <tr><td>0</td><td>Enable drive when CN1-13 input signal is ON (closed).</td></tr> <tr><td>1</td><td>Enable drive when CN1-7 input signal is ON (closed).</td></tr> <tr><td>2</td><td>Enable drive when CN1-8 input signal is ON (closed).</td></tr> <tr><td>3</td><td>Enable drive when CN1-9 input signal is ON (closed).</td></tr> <tr><td>4</td><td>Enable drive when CN1-10 input signal is ON (closed).</td></tr> <tr><td>5</td><td>Enable drive when CN1-11 input signal is ON (closed).</td></tr> <tr><td>6</td><td>Enable drive when CN1-12 input signal is ON (closed).</td></tr> <tr><td>7</td><td>Set the signal to always prohibit drive (always force the motor to stop).</td></tr> <tr><td>8</td><td>Set the signal to always enable drive (always disable forcing the motor to stop).</td></tr> <tr><td>9</td><td>Enable drive when CN1-13 input signal is OFF (open).</td></tr> <tr><td>A</td><td>Enable drive when CN1-7 input signal is OFF (open).</td></tr> <tr><td>B</td><td>Enable drive when CN1-8 input signal is OFF (open).</td></tr> <tr><td>C</td><td>Enable drive when CN1-9 input signal is OFF (open).</td></tr> <tr><td>D</td><td>Enable drive when CN1-10 input signal is OFF (open).</td></tr> <tr><td>E</td><td>Enable drive when CN1-11 input signal is OFF (open).</td></tr> <tr><td>F</td><td>Enable drive when CN1-12 input signal is OFF (open).</td></tr> <tr><td>n.□□□□</td><td>Reserved parameter (Do not change.)</td></tr> <tr><td>n.□X□□</td><td>Reserved parameter (Do not change.)</td></tr> <tr><td>n.X□□□</td><td>Reserved parameter (Do not change.)</td></tr> </tbody> </table> | | | | | | | | | | FSTP (Forced Stop Input) Signal Allocation | | 0 | Enable drive when CN1-13 input signal is ON (closed). | 1 | Enable drive when CN1-7 input signal is ON (closed). | 2 | Enable drive when CN1-8 input signal is ON (closed). | 3 | Enable drive when CN1-9 input signal is ON (closed). | 4 | Enable drive when CN1-10 input signal is ON (closed). | 5 | Enable drive when CN1-11 input signal is ON (closed). | 6 | Enable drive when CN1-12 input signal is ON (closed). | 7 | Set the signal to always prohibit drive (always force the motor to stop). | 8 | Set the signal to always enable drive (always disable forcing the motor to stop). | 9 | Enable drive when CN1-13 input signal is OFF (open). | A | Enable drive when CN1-7 input signal is OFF (open). | B | Enable drive when CN1-8 input signal is OFF (open). | C | Enable drive when CN1-9 input signal is OFF (open). | D | Enable drive when CN1-10 input signal is OFF (open). | E | Enable drive when CN1-11 input signal is OFF (open). | F | Enable drive when CN1-12 input signal is OFF (open). | n.□□□□ | Reserved parameter (Do not change.) | n.□X□□ | Reserved parameter (Do not change.) | n.X□□□ | Reserved parameter (Do not change.) |
| | FSTP (Forced Stop Input) Signal Allocation | | | | | | | | | | | | | | | | | | | | | | | | | | | | | | | | | | | | | | | | | | | | | | | | | |
| | 0 | Enable drive when CN1-13 input signal is ON (closed). | | | | | | | | | | | | | | | | | | | | | | | | | | | | | | | | | | | | | | | | | | | | | | | | |
| | 1 | Enable drive when CN1-7 input signal is ON (closed). | | | | | | | | | | | | | | | | | | | | | | | | | | | | | | | | | | | | | | | | | | | | | | | | |
| | 2 | Enable drive when CN1-8 input signal is ON (closed). | | | | | | | | | | | | | | | | | | | | | | | | | | | | | | | | | | | | | | | | | | | | | | | | |
| | 3 | Enable drive when CN1-9 input signal is ON (closed). | | | | | | | | | | | | | | | | | | | | | | | | | | | | | | | | | | | | | | | | | | | | | | | | |
| | 4 | Enable drive when CN1-10 input signal is ON (closed). | | | | | | | | | | | | | | | | | | | | | | | | | | | | | | | | | | | | | | | | | | | | | | | | |
| | 5 | Enable drive when CN1-11 input signal is ON (closed). | | | | | | | | | | | | | | | | | | | | | | | | | | | | | | | | | | | | | | | | | | | | | | | | |
| | 6 | Enable drive when CN1-12 input signal is ON (closed). | | | | | | | | | | | | | | | | | | | | | | | | | | | | | | | | | | | | | | | | | | | | | | | | |
| | 7 | Set the signal to always prohibit drive (always force the motor to stop). | | | | | | | | | | | | | | | | | | | | | | | | | | | | | | | | | | | | | | | | | | | | | | | | |
| | 8 | Set the signal to always enable drive (always disable forcing the motor to stop). | | | | | | | | | | | | | | | | | | | | | | | | | | | | | | | | | | | | | | | | | | | | | | | | |
| | 9 | Enable drive when CN1-13 input signal is OFF (open). | | | | | | | | | | | | | | | | | | | | | | | | | | | | | | | | | | | | | | | | | | | | | | | | |
| | A | Enable drive when CN1-7 input signal is OFF (open). | | | | | | | | | | | | | | | | | | | | | | | | | | | | | | | | | | | | | | | | | | | | | | | | |
| | B | Enable drive when CN1-8 input signal is OFF (open). | | | | | | | | | | | | | | | | | | | | | | | | | | | | | | | | | | | | | | | | | | | | | | | | |
| | C | Enable drive when CN1-9 input signal is OFF (open). | | | | | | | | | | | | | | | | | | | | | | | | | | | | | | | | | | | | | | | | | | | | | | | | |
| | D | Enable drive when CN1-10 input signal is OFF (open). | | | | | | | | | | | | | | | | | | | | | | | | | | | | | | | | | | | | | | | | | | | | | | | | |
| | E | Enable drive when CN1-11 input signal is OFF (open). | | | | | | | | | | | | | | | | | | | | | | | | | | | | | | | | | | | | | | | | | | | | | | | | |
| | F | Enable drive when CN1-12 input signal is OFF (open). | | | | | | | | | | | | | | | | | | | | | | | | | | | | | | | | | | | | | | | | | | | | | | | | |
| | n.□□□□ | Reserved parameter (Do not change.) | | | | | | | | | | | | | | | | | | | | | | | | | | | | | | | | | | | | | | | | | | | | | | | | |
| | n.□X□□ | Reserved parameter (Do not change.) | | | | | | | | | | | | | | | | | | | | | | | | | | | | | | | | | | | | | | | | | | | | | | | | |
| n.X□□□ | Reserved parameter (Do not change.) | | | | | | | | | | | | | | | | | | | | | | | | | | | | | | | | | | | | | | | | | | | | | | | | | |
| Pn518*4 | - | Safety Module-Related Parameters | - | - | - | All | - | - | - | | | | | | | | | | | | | | | | | | | | | | | | | | | | | | | | | | | | | | | | | |
| Pn51B | 4 | Motor-Load Position Deviation Overflow Detection Level | 0 to 1,073,741,824 | 1 reference unit | 1000 | Rotary | Immediately | Setup | *1 | | | | | | | | | | | | | | | | | | | | | | | | | | | | | | | | | | | | | | | | | |
| Pn51E | 2 | Position Deviation Overflow Warning Level | 10 to 100 | 1% | 100 | All | Immediately | Setup | *1 | | | | | | | | | | | | | | | | | | | | | | | | | | | | | | | | | | | | | | | | | |
| Pn520 | 4 | Position Deviation Overflow Alarm Level | 1 to 1,073,741,823 | 1 reference unit | 5242880 | All | Immediately | Setup | *1 | | | | | | | | | | | | | | | | | | | | | | | | | | | | | | | | | | | | | | | | | |
| Pn522 | 4 | Positioning Completed Width | 0 to 1,073,741,824 | 1 reference unit | 7 | All | Immediately | Setup | *1 | | | | | | | | | | | | | | | | | | | | | | | | | | | | | | | | | | | | | | | | | |
| Pn524 | 4 | Near Signal Width | 1 to 1,073,741,824 | 1 reference unit | 1073741824 | All | Immediately | Setup | *1 | | | | | | | | | | | | | | | | | | | | | | | | | | | | | | | | | | | | | | | | | |
| Pn526 | 4 | Position Deviation Overflow Alarm Level at Servo ON | 1 to 1,073,741,823 | 1 reference unit | 5242880 | All | Immediately | Setup | *1 | | | | | | | | | | | | | | | | | | | | | | | | | | | | | | | | | | | | | | | | | |
| Pn528 | 2 | Position Deviation Overflow Warning Level at Servo ON | 10 to 100 | 1% | 100 | All | Immediately | Setup | *1 | | | | | | | | | | | | | | | | | | | | | | | | | | | | | | | | | | | | | | | | | |
| Pn529 | 2 | Speed Limit Level at Servo ON | 0 to 10,000 | 1 min ⁻¹ | 10000 | Rotary | Immediately | Setup | *1 | | | | | | | | | | | | | | | | | | | | | | | | | | | | | | | | | | | | | | | | | |
| Pn52A | 2 | Multiplier per Fully-closed Rotation | 0 to 100 | 1% | 20 | Rotary | Immediately | Tuning | *1 | | | | | | | | | | | | | | | | | | | | | | | | | | | | | | | | | | | | | | | | | |
| Pn52B | 2 | Overload Warning Level | 1 to 100 | 1% | 20 | All | Immediately | Setup | *1 | | | | | | | | | | | | | | | | | | | | | | | | | | | | | | | | | | | | | | | | | |

Continued on next page.

5.2 SERVOPACKs with MECHATROLINK-III Communications References

5.2.2 List of Servo Parameters

Continued from previous page.

| Parameter No. | Size | Name | Setting Range | Setting Unit | Default Setting | Applicable Motors | When Enabled | Classification | Reference | | |
|---------------|--|---|-------------------------------------|--|-----------------|-------------------|---------------|----------------|-----------|--|--|
| Pn52C | 2 | Base Current Derating at Motor Overload Detection | 10 to 100 | 1% | 100 | All | After restart | Setup | *1 | | |
| Pn530 | 2 | Program Jogging-Related Selections | 0000h to 0005h | – | 0000h | All | Immediately | Setup | *1 | | |
| | Program Jogging Operation Pattern | | | | | | | | | | |
| | n.□□□X | | 0 | (Waiting time in Pn535 → Forward by travel distance in Pn531) × Number of movements in Pn536 | | | | | | | |
| | n.□□□X | | 1 | (Waiting time in Pn535 → Reverse by travel distance in Pn531) × Number of movements in Pn536 | | | | | | | |
| | n.□□□X | | 2 | (Waiting time in Pn535 → Forward by travel distance in Pn531) × Number of movements in Pn536 (Waiting time in Pn535 → Reverse by travel distance in Pn531) × Number of movements in Pn536 | | | | | | | |
| | n.□□□X | | 3 | (Waiting time in Pn535 → Reverse by travel distance in Pn531) × Number of movements in Pn536 (Waiting time in Pn535 → Forward by travel distance in Pn531) × Number of movements in Pn536 | | | | | | | |
| | n.□□□X | | 4 | (Waiting time in Pn535 → Forward by travel distance in Pn531 → Waiting time in Pn535 → Reverse by travel distance in Pn531) × Number of movements in Pn536 | | | | | | | |
| | n.□□□X | | 5 | (Waiting time in Pn535 → Reverse by travel distance in Pn531 → Waiting time in Pn535 → Forward by travel distance in Pn531) × Number of movements in Pn536 | | | | | | | |
| | n.□□X□ | | Reserved parameter (Do not change.) | | | | | | | | |
| | n.□X□□ | | Reserved parameter (Do not change.) | | | | | | | | |
| n.X□□□ | | Reserved parameter (Do not change.) | | | | | | | | | |
| Pn531 | 4 | Program Jogging Travel Distance | 1 to 1,073,741,824 | 1 reference unit | 32768 | All | Immediately | Setup | *1 | | |
| Pn533 | 2 | Program Jogging Movement Speed | 1 to 10,000 | Rotary: 1 min ⁻¹ Direct Drive: 0.1 min ⁻¹ | 500 | Rotary | Immediately | Setup | *1 | | |
| Pn534 | 2 | Program Jogging Acceleration/Deceleration Time | 2 to 10,000 | 1 ms | 100 | All | Immediately | Setup | *1 | | |
| Pn535 | 2 | Program Jogging Waiting Time | 0 to 10,000 | 1 ms | 100 | All | Immediately | Setup | *1 | | |
| Pn536 | 2 | Program Jogging Number of Movements | 0 to 1,000 | Times | 1 | All | Immediately | Setup | *1 | | |
| Pn550 | 2 | Analog Monitor 1 Offset Voltage | -10,000 to 10,000 | 0.1 V | 0 | All | Immediately | Setup | *1 | | |
| Pn551 | 2 | Analog Monitor 2 Offset Voltage | -10,000 to 10,000 | 0.1 V | 0 | All | Immediately | Setup | *1 | | |
| Pn552 | 2 | Analog Monitor 1 Magnification | -10,000 to 10,000 | × 0.01 | 100 | All | Immediately | Setup | *1 | | |
| Pn553 | 2 | Analog Monitor 2 Magnification | -10,000 to 10,000 | × 0.01 | 100 | All | Immediately | Setup | *1 | | |
| Pn55A | 2 | Power Consumption Monitor Unit Time | 1 to 1,440 | 1 min | 1 | All | Immediately | Setup | – | | |
| Pn560 | 2 | Residual Vibration Detection Width | 1 to 3,000 | 0.1% | 400 | All | Immediately | Setup | *1 | | |
| Pn561 | 2 | Overshoot Detection Level | 0 to 100 | 1% | 100 | All | Immediately | Setup | *1 | | |
| Pn581 | 2 | Zero Speed Level | 1 to 10,000 | 1 mm/s | 20 | Linear | Immediately | Setup | *1 | | |

Continued on next page.

Continued from previous page.

| Parameter No. | Size | Name | Setting Range | Setting Unit | Default Setting | Applicable Motors | When Enabled | Classification | Reference | | |
|---------------|------|---|---------------------|---|-----------------|-------------------|---------------|----------------|-----------|----|--|
| Pn582 | 2 | Speed Coincidence Detection Signal Output Width | 0 to 100 | 1 mm/s | 10 | Linear | Immediately | Setup | *1 | | |
| Pn583 | 2 | Brake Reference Output Speed Level | 0 to 10,000 | 1 mm/s | 10 | Linear | Immediately | Setup | *1 | | |
| Pn584 | 2 | Speed Limit Level at Servo ON | 0 to 10,000 | 1 mm/s | 10000 | Linear | Immediately | Setup | *1 | | |
| Pn585 | 2 | Program Jogging Movement Speed | 1 to 10,000 | 1 mm/s | 50 | Linear | Immediately | Setup | *1 | | |
| Pn586 | 2 | Motor Running Cooling Ratio | 0 to 100 | 1%/Max. speed | 0 | Linear | Immediately | Setup | – | | |
| Pn587 | 2 | Polarity Detection Execution Selection for Absolute Linear Encoder | | 0000h to 0001h | – | 0000h | Linear | Immediately | Setup | *1 | |
| | | n.□□□X Polarity Detection Selection for Absolute Linear Encoder | | | | | | | | | |
| | | 0 | | Do not detect polarity. | | | | | | | |
| | | 1 | | Detect polarity. | | | | | | | |
| | | n.□□X□ | | Reserved parameter (Do not change.) | | | | | | | |
| | | n.□X□□ | | Reserved parameter (Do not change.) | | | | | | | |
| n.X□□□ | | Reserved parameter (Do not change.) | | | | | | | | | |
| Pn600 | 2 | Regenerative Resistor Capacity*5 | Depends on model.*6 | 10 W | 0 | All | Immediately | Setup | *1 | | |
| Pn601 | 2 | Dynamic Brake Resistor Allowable Energy Consumption | 0 to 65,535 | 10 J | 0 | All | After restart | Setup | *7 | | |
| Pn603 | 2 | Regenerative Resistance | 0 to 65,535 | 10 mΩ | 0 | All | Immediately | Setup | *1 | | |
| Pn604 | 2 | Dynamic Brake Resistance | 0 to 65,535 | 10 mΩ | 0 | All | After restart | Setup | *7 | | |
| Pn61A | 2 | Overheat Protection Selections | | 0000h to 0003h | – | 0000h | All | After restart | Setup | *1 | |
| | | n.□□□X Overheat Protection Selection | | | | | | | | | |
| | | 0 | | Disable overheat protection. | | | | | | | |
| | | 1 | | Use overheat protection in the Yaskawa Linear Servomotor.*8 | | | | | | | |
| | | 2 | | Monitor a negative voltage input from a sensor attached to the machine and use overheat protection. | | | | | | | |
| | | 3 | | Monitor a positive voltage input from a sensor attached to the machine and use overheat protection. | | | | | | | |
| n.□□X□ | | Reserved parameter (Do not change.) | | | | | | | | | |
| n.□X□□ | | Reserved parameter (Do not change.) | | | | | | | | | |
| n.X□□□ | | Reserved parameter (Do not change.) | | | | | | | | | |
| Pn61B*9 | 2 | Overheat Alarm Level | 0 to 500 | 0.01 V | 250 | All | Immediately | Setup | *1 | | |
| Pn61C*9 | 2 | Overheat Warning Level | 0 to 100 | 1% | 100 | All | Immediately | Setup | *1 | | |
| Pn61D*9 | 2 | Overheat Alarm Filter Time | 0 to 65,535 | 1 s | 0 | All | Immediately | Setup | *1 | | |

Continued on next page.

5.2 SERVOPACKs with MECHATROLINK-III Communications References

5.2.2 List of Servo Parameters

Continued from previous page.

| Parameter No. | Size | Name | Setting Range | Setting Unit | Default Setting | Applicable Motors | When Enabled | Classification | Reference |
|------------------|---|--|--|--------------|-----------------|-------------------|--------------|----------------|-----------|
| Pn621 to Pn628*4 | - | Safety Module-Related Parameters | - | - | - | All | - | - | - |
| Pn800 | 2 | Communications Controls | 0000h to 1FF3h | - | 1040h | All | Immediately | Setup | - |
| | n.□□□X | MECHATROLINK Communications Check Mask for Debugging | | | | | | | |
| | | 0 | Do not mask. | | | | | | |
| | | 1 | Ignore MECHATROLINK communications errors (A.E60). | | | | | | |
| | | 2 | Ignore WDT errors (A.E50). | | | | | | |
| | | 3 | Ignore both MECHATROLINK communications errors (A.E60) and WDT errors (A.E50). | | | | | | |
| | n.□□X□ | Warning Check Masks | | | | | | | |
| | | 0 | Do not mask. | | | | | | |
| | | 1 | Ignore data setting warnings (A.94□). | | | | | | |
| | | 2 | Ignore command warnings (A.95□). | | | | | | |
| | | 3 | Ignore both A.94□ and A.95□ warnings. | | | | | | |
| | | 4 | Ignore communications warnings (A.96□). | | | | | | |
| | | 5 | Ignore both A.94□ and A.96□ warnings. | | | | | | |
| | | 6 | Ignore both A.95□ and A.96□ warnings. | | | | | | |
| | | 7 | Ignore A.94□, A.95□, and A.96□ warnings. | | | | | | |
| | 8 | Ignore data setting warnings (A.97A and A.97b). | | | | | | | |
| | 9 | Ignore A.94□, A.97A, and A.97b warnings. | | | | | | | |
| | A | Ignore A.95□, A.97A, and A.97b warnings. | | | | | | | |
| | B | Ignore A.94□, A.95□, A.97A, and A.97b warnings. | | | | | | | |
| | C | Ignore A.96□, A.97A, and A.97b warnings. | | | | | | | |
| | D | Ignore A.94□, A.96□, A.97A, and A.97b warnings. | | | | | | | |
| | E | Ignore A.95□, A.96□, A.97A, and A.97b warnings. | | | | | | | |
| | F | Ignore A.94□, A.95□, A.96□, A.97A, and A.97b warnings. | | | | | | | |
| n.□X□□ | Reserved parameter (Do not change.) | | | | | | | | |
| n.X□□□ | Automatic Warning Clear Selection for Debugging*10 | | | | | | | | |
| M3*10 | 0 | Retain warnings for debugging. | | | | | | | |
| | 1 | Automatically clear warnings (MECHATROLINK-III specification). | | | | | | | |
| Pn801 | 2 | Application Function Selections 6 (Software Limits) | 0000h to 0103h | - | 0003h | All | Immediately | Setup | *1 |
| | n.□□□X | Software Limit Selection | | | | | | | |
| | | 0 | Enable both forward and reverse software limits. | | | | | | |
| | | 1 | Disable forward software limit. | | | | | | |
| | | 2 | Disable reverse software limit. | | | | | | |
| | | 3 | Disable both forward and reverse software limits. | | | | | | |
| | n.□□X□ | Reserved parameter (Do not change.) | | | | | | | |
| | n.□X□□ | Software Limit Check for References | | | | | | | |
| | | 0 | Do not perform software limit checks for references. | | | | | | |
| | | 1 | Perform software limit checks for references. | | | | | | |
| n.X□□□ | Reserved parameter (Do not change.) | | | | | | | | |

Continued on next page.

Continued from previous page.

| Parameter No. | Size | Name | Setting Range | Setting Unit | Default Setting | Applicable Motors | When Enabled | Classification | Reference |
|---------------|------|---|---------------------------------|---------------------------------------|-----------------|-------------------|-----------------|----------------|-----------|
| Pn803 | 2 | Origin Range | 0 to 250 | 1 reference unit | 10 | All | Immediately | Setup | *2 |
| Pn804 | 4 | Forward Software Limit | -1,073,741,823 to 1,073,741,823 | 1 reference unit | 1073741823 | All | Immediately | Setup | *1 |
| Pn806 | 4 | Reverse Software Limit | -1,073,741,823 to 1,073,741,823 | 1 reference unit | -1073741823 | All | Immediately | Setup | *1 |
| Pn808 | 4 | Absolute Encoder Origin Offset | -1,073,741,823 to 1,073,741,823 | 1 reference unit | 0 | All | Immediately *11 | Setup | *1 |
| Pn80A | 2 | First Stage Linear Acceleration Constant | 1 to 65,535 | 10,000 reference units/s ² | 100 | All | Immediately *12 | Setup | *2 |
| Pn80B | 2 | Second Stage Linear Acceleration Constant | 1 to 65,535 | 10,000 reference units/s ² | 100 | All | Immediately *12 | Setup | *2 |
| Pn80C | 2 | Acceleration Constant Switching Speed | 0 to 65,535 | 100 reference units/s | 0 | All | Immediately *12 | Setup | *2 |
| Pn80D | 2 | First Stage Linear Deceleration Constant | 1 to 65,535 | 10,000 reference units/s ² | 100 | All | Immediately *12 | Setup | *2 |
| Pn80E | 2 | Second Stage Linear Deceleration Constant | 1 to 65,535 | 10,000 reference units/s ² | 100 | All | Immediately *12 | Setup | *2 |
| Pn80F | 2 | Deceleration Constant Switching Speed | 0 to 65,535 | 100 reference units/s | 0 | All | Immediately *12 | Setup | *2 |
| Pn810 | 2 | Exponential Acceleration/Deceleration Bias | 0 to 65,535 | 100 reference units/s | 0 | All | Immediately *13 | Setup | *2 |
| Pn811 | 2 | Exponential Acceleration/Deceleration Time Constant | 0 to 5,100 | 0.1 ms | 0 | All | Immediately *13 | Setup | *2 |
| Pn812 | 2 | Movement Average Time | 0 to 5,100 | 0.1 ms | 0 | All | Immediately *13 | Setup | *2 |
| Pn814 | 4 | External Positioning Final Travel Distance | -1,073,741,823 to 1,073,741,823 | 1 reference unit | 100 | All | Immediately | Setup | *2 |
| Pn816 | 2 | Origin Return Mode Settings | 0000h to 0001h | - | 0000h | All | Immediately | Setup | *14 |
| | | n.□□□X | | Origin Return Direction | | | | | |
| | | 0 | | Return in forward direction. | | | | | |
| | | 1 | | Return in reverse direction. | | | | | |
| | | n.□□X□ | | Reserved parameter (Do not change.) | | | | | |
| | | n.□X□□ | | Reserved parameter (Do not change.) | | | | | |
| n.X□□□ | | Reserved parameter (Do not change.) | | | | | | | |
| Pn817 *16 | 2 | Origin Approach Speed 1 | 0 to 65,535 | 100 reference units/s | 50 | All | Immediately *12 | Setup | *2 |
| Pn818 *17 | 2 | Origin Approach Speed 2 | 0 to 65,535 | 100 reference units/s | 5 | All | Immediately *12 | Setup | *2 |

Continued on next page.

Continued from previous page.

| Parameter No. | Size | Name | Setting Range | Setting Unit | Default Setting | Applicable Motors | When Enabled | Classification | Reference | |
|------------------------|--------|---|--|----------------------------------|------------------|-------------------|---------------|----------------|-----------|----|
| Pn819 | 4 | Final Travel Distance for Origin Return | -1,073,741,823 to 1,073,741,823 | 1 reference unit | 100 | All | Immediately | Setup | *2 | |
| Pn81E M2 *15 | 2 | Input Signal Monitor Selections | 0000h to 7777h | - | 0000h | All | Immediately | Setup | *14 | |
| | | | IO12 Signal Mapping | | | | | | | |
| | n.□□□X | | 0 | Do not map. | | | | | | |
| | n.□□□X | | 1 | Monitor CN1-13 input terminal. | | | | | | |
| | n.□□□X | | 2 | Monitor CN1-7 input terminal. | | | | | | |
| | n.□□□X | | 3 | Monitor CN1-8 input terminal. | | | | | | |
| | n.□□□X | | 4 | Monitor CN1-9 input terminal. | | | | | | |
| | n.□□□X | | 5 | Monitor CN1-10 input terminal. | | | | | | |
| | n.□□□X | | 6 | Monitor CN1-11 input terminal. | | | | | | |
| | n.□□□X | | 7 | Monitor CN1-12 input terminal. | | | | | | |
| | | IO13 Signal Mapping | | | | | | | | |
| n.□□X□ | | 0 to 7 | The mappings are the same as the IO12 signal mappings. | | | | | | | |
| | | IO14 Signal Mapping | | | | | | | | |
| n.□X□□ | | 0 to 7 | The mappings are the same as the IO12 signal mappings. | | | | | | | |
| | | IO15 Signal Mapping | | | | | | | | |
| n.X□□□ | | 0 to 7 | The mappings are the same as the IO12 signal mappings. | | | | | | | |
| Pn81F M2 *15 | 2 | Command Data Allocations | 0000h to 1111h | - | 0010h | All | After restart | Setup | *14 | |
| | | | Option Field Allocation | | | | | | | |
| | n.□□□X | | 0 | Disable option field allocation. | | | | | | |
| | n.□□□X | | 1 | Enable option field allocation. | | | | | | |
| | | | Position Control Command TFF/TLIM Allocation | | | | | | | |
| | n.□□X□ | | 0 | Disable allocation. | | | | | | |
| | n.□□X□ | | 1 | Enable allocation. | | | | | | |
| | n.□X□□ | | Reserved parameter (Do not change.) | | | | | | | |
| | n.X□□□ | | Reserved parameter (Do not change.) | | | | | | | |
| | Pn820 | 4 | Forward Latching Area | -2,147,483,648 to 2,147,483,647 | 1 reference unit | 0 | All | Immediately | Setup | *2 |
| Pn822 | 4 | Reverse Latching Area | -2,147,483,648 to 2,147,483,647 | 1 reference unit | 0 | All | Immediately | Setup | *2 | |

Continued on next page.

Continued from previous page.

| Parameter No. | Size | Name | Setting Range | Setting Unit | Default Setting | Applicable Motors | When Enabled | Classification | Reference | |
|-----------------------------------|----------------------------------|----------------------------|----------------|---|-----------------|-------------------|--------------------------|----------------|-----------|--|
| Pn824 M3 ^{*10} | 2 | Option Monitor 1 Selection | 0000h to FFFFh | – | 0000h | – | Immediately | Setup | *2 | |
| | | | Setting | Monitor | | | Applicable Motors | | | |
| | High-Speed Monitor Region | | | | | | | | | |
| | | | 0000h | Motor speed [overspeed detection speed ^{*18} /1000000h] | | | | All | | |
| | | | 0001h | Speed reference [overspeed detection speed ^{*18} /1000000h] | | | | All | | |
| | | | 0002h | Torque [maximum torque/1000000h] | | | | All | | |
| | | | 0003h | Position deviation (lower 32 bits) [reference units] | | | | All | | |
| | | | 0004h | Position deviation (upper 32 bits) [reference units] | | | | All | | |
| | | | 000Ah | Encoder count (lower 32 bits) [reference units] | | | | All | | |
| | | | 000Bh | Encoder count (upper 32 bits) [reference units] | | | | All | | |
| | | | 000Ch | FPG count (lower 32 bits) [reference units] | | | | All | | |
| | | | 000Dh | FPG count (upper 32 bits) [reference units] | | | | All | | |
| | Low-Speed Monitor Region | | | | | | | | | |
| | | | 0010h | Un000: Motor speed [min ⁻¹] | | | | All | | |
| | | | 0011h | Un001: Speed Reference [min ⁻¹] | | | | All | | |
| | | | 0012h | Un002: Torque Reference [%] | | | | All | | |
| | | | 0013h | Un003: Rotational Angle 1 [encoder pulses] Number of encoder pulses from origin within one encoder rotation displayed in decimal | | | | All | | |
| | | | | Un003: Rotational Angle 1 [linear encoder pulses] Linear encoder pulses from the polarity origin displayed in decimal | | | | | | |
| | | | 0014h | Un004: Rotational Angle 2 [deg] Electrical angle from polarity origin | | | | All | | |
| | | | | Un004: Electrical Angle 2 [deg] Electrical angle from polarity origin | | | | | | |
| | | | 0015h | Un005: Input Signal Monitor | | | | All | | |
| | | | 0016h | Un006: Output Signal Monitor | | | | All | | |
| | | | 0017h | Un007: Input Reference Speed [min ⁻¹] | | | | All | | |
| | | | 0018h | Un008: Position Deviation [reference units] | | | | All | | |
| | | | 0019h | Un009: Accumulated Load Ratio [%] | | | | All | | |
| | | | 001Ah | Un00A: Regenerative Load Ratio [%] | | | | All | | |
| | | | 001Bh | Un00B: Dynamic Brake Resistor Power Consumption [%] | | | | All | | |
| | | | 001Ch | Un00C: Input Reference Pulse Counter [reference units] | | | | All | | |
| | | | 001Dh | Un00D: Feedback Pulse Counter [encoder pulses] | | | | All | | |
| | | | 001Eh | Un00E: Fully-closed Loop Feedback Pulse Counter [external encoder resolution] | | | | Rotary | | |
| | | | 0023h | Initial multiturn data [Rev] | | | | Rotary | | |
| | | | 0024h | Initial incremental data [pulses] | | | | Rotary | | |
| | | | 0025h | Initial absolute position data (lower 32 bits) [pulses] | | | | Linear | | |
| | | | 0026h | Initial absolute position data (upper 32 bits) [pulses] | | | | Linear | | |
| | | | 0040h | Un025: SERVOPACK Installation Environment Monitor | | | | All | | |
| | | | 0041h | Un026: Servomotor Installation Environment Monitor | | | | All | | |
| | | | 0042h | Un027: Built-in Fan Remaining Life Ratio | | | | All | | |
| | | | 0043h | Un028: Capacitor Remaining Life Ratio | | | | All | | |
| | | | 0044h | Un029: Surge Prevention Circuit Remaining Life Ratio | | | | All | | |
| | | | 0045h | Un02A: Dynamic Brake Circuit Remaining Life Ratio | | | | All | | |
| | | | 0046h | Un032: Instantaneous Power | | | | All | | |
| | | | 0047h | Un033: Power Consumption | | | | All | | |
| | | | 0048h | Un034: Cumulative Power Consumption | | | | All | | |

Continued on next page.

Continued from previous page.

| Parameter No. | Size | Name | Setting Range | Setting Unit | Default Setting | Applicable Motors | When Enabled | Classification | Reference | | |
|--|------------------------------------|--|--|---------------------------------------|-----------------|-------------------|-------------------|----------------|-----------|-----|--|
| Pn824 | M3*10 | Setting | | Monitor | | | Applicable Motors | | | | |
| | | Communications Module Only | | | | | | | | | |
| | | 0080h | Previous value of latched feedback position (LPOS1) [reference units] | | | | | All | | | |
| | | 0081h | Previous value of latched feedback position (LPOS2) [reference units] | | | | | All | | | |
| | | 0084h | Continuous Latch Status (EX STATUS) | | | | | All | | | |
| | | All Areas | | | | | | | | | |
| | | Other values | Reserved settings (Do not use.) | | | | | All | | | |
| Pn825 | 2 | Option Monitor 2 Selection | 0000h to FFFFh | – | 0000h | All | Immediately | Setup | *2 | | |
| | | 0000h to 0084h | The settings are the same as those for the Option Monitor 1 Selection. | | | | | | | | |
| Pn827 | 2 | Linear Deceleration Constant 1 for Stopping | 1 to 65,535 | 10,000 reference units/s ² | 100 | All | Immediately*12 | Setup | *2 | | |
| Pn829 | 2 | SVOFF Waiting Time (for SVOFF at Deceleration to Stop) | 0 to 65,535 | 10 ms | 0 | All | Immediately*12 | Setup | *2 | | |
| Pn82A | M2*15 | 2 | Option Field Allocations 1 | 0000h to 1E1Eh | – | 1813h | All | After restart | Setup | *12 | |
| | | ACCFIL Allocation (Option) | | | | | | | | | |
| | | n.□□□X | 0 | Allocate bits 0 and 1 to ACCFIL. | | | | | | | |
| | | | 1 | Allocate bits 1 and 2 to ACCFIL. | | | | | | | |
| | | | 2 | Allocate bits 2 and 3 to ACCFIL. | | | | | | | |
| | | | 3 | Allocate bits 3 and 4 to ACCFIL. | | | | | | | |
| | | | 4 | Allocate bits 4 and 5 to ACCFIL. | | | | | | | |
| | | | 5 | Allocate bits 5 and 6 to ACCFIL. | | | | | | | |
| | | | 6 | Allocate bits 6 and 7 to ACCFIL. | | | | | | | |
| | | | 7 | Allocate bits 7 and 8 to ACCFIL. | | | | | | | |
| | | | 8 | Allocate bits 8 and 9 to ACCFIL. | | | | | | | |
| | | | 9 | Allocate bits 9 and 10 to ACCFIL. | | | | | | | |
| | | A | Allocate bits 10 and 11 to ACCFIL. | | | | | | | | |
| | | B | Allocate bits 11 and 12 to ACCFIL. | | | | | | | | |
| | | C | Allocate bits 12 and 13 to ACCFIL. | | | | | | | | |
| D | Allocate bits 13 and 14 to ACCFIL. | | | | | | | | | | |
| E | Allocate bits 14 and 15 to ACCFIL. | | | | | | | | | | |
| ACCFIL Allocation Enable/Disable Selection | | | | | | | | | | | |
| n.□□X□ | 0 | Disable ACCFIL allocation. | | | | | | | | | |
| | 1 | Enable ACCFIL allocation. | | | | | | | | | |
| G_SEL Allocation (Option) | | | | | | | | | | | |
| n.□X□□ | 0 to E | The settings are the same as for the ACCFIL allocations. | | | | | | | | | |
| G_SEL Allocation Enable/Disable Selection | | | | | | | | | | | |
| n. X□□□ | 0 | Disable G_SEL allocation. | | | | | | | | | |
| | 1 | Enable G_SEL allocation. | | | | | | | | | |

Continued on next page.

Continued from previous page.

| Parameter No. | Size | Name | Setting Range | Setting Unit | Default Setting | Applicable Motors | When Enabled | Classification | Reference | | | | | | | | | | | | | | | | | | | | | | | | | | | | | | | | | | | |
|---|--|--|---|--------------|-----------------|-------------------|---------------|----------------|-----------|---|--|--------|--------|------------------------------|---|--------------------------|-----------------------------|--------------------------|---|--------------------------|---|--------------------------|---|--------------------------|---|--------------------------|--------|--------------------------|--|--------------------------|--|--------------------------|---|---------------------------|---|---------------------------|---|---------------------------|---|---------------------------|---|---------------------------|---|---------------------------|
| Pn82B M2 ^{*15} | 2 | Option Field Allocations ₂ | 0000h to 1F1Fh | - | 1D1Ch | All | After restart | Setup | *14 | | | | | | | | | | | | | | | | | | | | | | | | | | | | | | | | | | | |
| | | | <table border="1"> <tr> <td colspan="2">V_PPI Allocation (Option)</td> </tr> <tr> <td>0</td> <td>Allocate bit 0 to V_PPI.</td> </tr> <tr> <td>1</td> <td>Allocate bit 1 to V_PPI.</td> </tr> <tr> <td>2</td> <td>Allocate bit 2 to V_PPI.</td> </tr> <tr> <td>3</td> <td>Allocate bit 3 to V_PPI.</td> </tr> <tr> <td>4</td> <td>Allocate bit 4 to V_PPI.</td> </tr> <tr> <td>5</td> <td>Allocate bit 5 to V_PPI.</td> </tr> <tr> <td>6</td> <td>Allocate bit 6 to V_PPI.</td> </tr> <tr> <td>n.□□□X</td> <td>Allocate bit 7 to V_PPI.</td> </tr> <tr> <td></td> <td>Allocate bit 8 to V_PPI.</td> </tr> <tr> <td></td> <td>Allocate bit 9 to V_PPI.</td> </tr> <tr> <td>A</td> <td>Allocate bit 10 to V_PPI.</td> </tr> <tr> <td>B</td> <td>Allocate bit 11 to V_PPI.</td> </tr> <tr> <td>C</td> <td>Allocate bit 12 to V_PPI.</td> </tr> <tr> <td>D</td> <td>Allocate bit 13 to V_PPI.</td> </tr> <tr> <td>E</td> <td>Allocate bit 14 to V_PPI.</td> </tr> <tr> <td>F</td> <td>Allocate bit 15 to V_PPI.</td> </tr> </table> | | | | | | | | V_PPI Allocation (Option) | | 0 | Allocate bit 0 to V_PPI. | 1 | Allocate bit 1 to V_PPI. | 2 | Allocate bit 2 to V_PPI. | 3 | Allocate bit 3 to V_PPI. | 4 | Allocate bit 4 to V_PPI. | 5 | Allocate bit 5 to V_PPI. | 6 | Allocate bit 6 to V_PPI. | n.□□□X | Allocate bit 7 to V_PPI. | | Allocate bit 8 to V_PPI. | | Allocate bit 9 to V_PPI. | A | Allocate bit 10 to V_PPI. | B | Allocate bit 11 to V_PPI. | C | Allocate bit 12 to V_PPI. | D | Allocate bit 13 to V_PPI. | E | Allocate bit 14 to V_PPI. | F | Allocate bit 15 to V_PPI. |
| | V_PPI Allocation (Option) | | | | | | | | | | | | | | | | | | | | | | | | | | | | | | | | | | | | | | | | | | | |
| | 0 | Allocate bit 0 to V_PPI. | | | | | | | | | | | | | | | | | | | | | | | | | | | | | | | | | | | | | | | | | | |
| | 1 | Allocate bit 1 to V_PPI. | | | | | | | | | | | | | | | | | | | | | | | | | | | | | | | | | | | | | | | | | | |
| | 2 | Allocate bit 2 to V_PPI. | | | | | | | | | | | | | | | | | | | | | | | | | | | | | | | | | | | | | | | | | | |
| | 3 | Allocate bit 3 to V_PPI. | | | | | | | | | | | | | | | | | | | | | | | | | | | | | | | | | | | | | | | | | | |
| | 4 | Allocate bit 4 to V_PPI. | | | | | | | | | | | | | | | | | | | | | | | | | | | | | | | | | | | | | | | | | | |
| | 5 | Allocate bit 5 to V_PPI. | | | | | | | | | | | | | | | | | | | | | | | | | | | | | | | | | | | | | | | | | | |
| | 6 | Allocate bit 6 to V_PPI. | | | | | | | | | | | | | | | | | | | | | | | | | | | | | | | | | | | | | | | | | | |
| | n.□□□X | Allocate bit 7 to V_PPI. | | | | | | | | | | | | | | | | | | | | | | | | | | | | | | | | | | | | | | | | | | |
| | | Allocate bit 8 to V_PPI. | | | | | | | | | | | | | | | | | | | | | | | | | | | | | | | | | | | | | | | | | | |
| | | Allocate bit 9 to V_PPI. | | | | | | | | | | | | | | | | | | | | | | | | | | | | | | | | | | | | | | | | | | |
| | A | Allocate bit 10 to V_PPI. | | | | | | | | | | | | | | | | | | | | | | | | | | | | | | | | | | | | | | | | | | |
| | B | Allocate bit 11 to V_PPI. | | | | | | | | | | | | | | | | | | | | | | | | | | | | | | | | | | | | | | | | | | |
| | C | Allocate bit 12 to V_PPI. | | | | | | | | | | | | | | | | | | | | | | | | | | | | | | | | | | | | | | | | | | |
| | D | Allocate bit 13 to V_PPI. | | | | | | | | | | | | | | | | | | | | | | | | | | | | | | | | | | | | | | | | | | |
| | E | Allocate bit 14 to V_PPI. | | | | | | | | | | | | | | | | | | | | | | | | | | | | | | | | | | | | | | | | | | |
| | F | Allocate bit 15 to V_PPI. | | | | | | | | | | | | | | | | | | | | | | | | | | | | | | | | | | | | | | | | | | |
| | | | <table border="1"> <tr> <td colspan="2">V_PPI Allocation Enable/Disable Selection</td> </tr> <tr> <td>n.□□X□</td> <td>0</td> <td>Disable V_PPI allocation.</td> </tr> <tr> <td></td> <td>1</td> <td>Enable V_PPI allocation.</td> </tr> </table> | | | | | | | | V_PPI Allocation Enable/Disable Selection | | n.□□X□ | 0 | Disable V_PPI allocation. | | 1 | Enable V_PPI allocation. | | | | | | | | | | | | | | | | | | | | | | | | | | |
| | V_PPI Allocation Enable/Disable Selection | | | | | | | | | | | | | | | | | | | | | | | | | | | | | | | | | | | | | | | | | | | |
| | n.□□X□ | 0 | Disable V_PPI allocation. | | | | | | | | | | | | | | | | | | | | | | | | | | | | | | | | | | | | | | | | | |
| | | 1 | Enable V_PPI allocation. | | | | | | | | | | | | | | | | | | | | | | | | | | | | | | | | | | | | | | | | | |
| | | | <table border="1"> <tr> <td colspan="2">P_PI_CLR Allocation (Option)</td> </tr> <tr> <td>n.□X□□</td> <td>0 to F</td> <td>The settings are the same as for the V_PPI allocations.</td> </tr> </table> | | | | | | | | P_PI_CLR Allocation (Option) | | n.□X□□ | 0 to F | The settings are the same as for the V_PPI allocations. | | | | | | | | | | | | | | | | | | | | | | | | | | | | | |
| P_PI_CLR Allocation (Option) | | | | | | | | | | | | | | | | | | | | | | | | | | | | | | | | | | | | | | | | | | | | |
| n.□X□□ | 0 to F | The settings are the same as for the V_PPI allocations. | | | | | | | | | | | | | | | | | | | | | | | | | | | | | | | | | | | | | | | | | | |
| | | <table border="1"> <tr> <td colspan="2">P_PI_CLR Allocation Enable/Disable Selection</td> </tr> <tr> <td>n.X□□□</td> <td>0</td> <td>Disable P_PI_CLR allocation.</td> </tr> <tr> <td></td> <td>1</td> <td>Enable P_PI_CLR allocation.</td> </tr> </table> | | | | | | | | P_PI_CLR Allocation Enable/Disable Selection | | n.X□□□ | 0 | Disable P_PI_CLR allocation. | | 1 | Enable P_PI_CLR allocation. | | | | | | | | | | | | | | | | | | | | | | | | | | | |
| P_PI_CLR Allocation Enable/Disable Selection | | | | | | | | | | | | | | | | | | | | | | | | | | | | | | | | | | | | | | | | | | | | |
| n.X□□□ | 0 | Disable P_PI_CLR allocation. | | | | | | | | | | | | | | | | | | | | | | | | | | | | | | | | | | | | | | | | | | |
| | 1 | Enable P_PI_CLR allocation. | | | | | | | | | | | | | | | | | | | | | | | | | | | | | | | | | | | | | | | | | | |
| Pn82C M2 ^{*15} | 2 | Option Field Allocations ₃ | 0000h to 1F1Fh | - | 1F1Eh | All | After restart | Setup | *14 | | | | | | | | | | | | | | | | | | | | | | | | | | | | | | | | | | | |
| | | | <table border="1"> <tr> <td colspan="2">P_CL Allocation (Option)</td> </tr> <tr> <td>n.□□□X</td> <td>0 to F</td> <td>The settings are the same as for the V_PPI allocations.</td> </tr> </table> | | | | | | | | P_CL Allocation (Option) | | n.□□□X | 0 to F | The settings are the same as for the V_PPI allocations. | | | | | | | | | | | | | | | | | | | | | | | | | | | | | |
| | P_CL Allocation (Option) | | | | | | | | | | | | | | | | | | | | | | | | | | | | | | | | | | | | | | | | | | | |
| | n.□□□X | 0 to F | The settings are the same as for the V_PPI allocations. | | | | | | | | | | | | | | | | | | | | | | | | | | | | | | | | | | | | | | | | | |
| | | | <table border="1"> <tr> <td colspan="2">P_CL Allocation Enable/Disable Selection</td> </tr> <tr> <td>n.□□X□</td> <td>0</td> <td>Disable P_CL allocation.</td> </tr> <tr> <td></td> <td>1</td> <td>Enable P_CL allocation.</td> </tr> </table> | | | | | | | | P_CL Allocation Enable/Disable Selection | | n.□□X□ | 0 | Disable P_CL allocation. | | 1 | Enable P_CL allocation. | | | | | | | | | | | | | | | | | | | | | | | | | | |
| | P_CL Allocation Enable/Disable Selection | | | | | | | | | | | | | | | | | | | | | | | | | | | | | | | | | | | | | | | | | | | |
| | n.□□X□ | 0 | Disable P_CL allocation. | | | | | | | | | | | | | | | | | | | | | | | | | | | | | | | | | | | | | | | | | |
| | | 1 | Enable P_CL allocation. | | | | | | | | | | | | | | | | | | | | | | | | | | | | | | | | | | | | | | | | | |
| | | | <table border="1"> <tr> <td colspan="2">N_CL Allocation (Option)</td> </tr> <tr> <td>n.□X□□</td> <td>0 to F</td> <td>The settings are the same as for the V_PPI allocations.</td> </tr> </table> | | | | | | | | N_CL Allocation (Option) | | n.□X□□ | 0 to F | The settings are the same as for the V_PPI allocations. | | | | | | | | | | | | | | | | | | | | | | | | | | | | | |
| | N_CL Allocation (Option) | | | | | | | | | | | | | | | | | | | | | | | | | | | | | | | | | | | | | | | | | | | |
| n.□X□□ | 0 to F | The settings are the same as for the V_PPI allocations. | | | | | | | | | | | | | | | | | | | | | | | | | | | | | | | | | | | | | | | | | | |
| | | <table border="1"> <tr> <td colspan="2">N_CL Allocation Enable/Disable Selection</td> </tr> <tr> <td>n.X□□□</td> <td>0</td> <td>Disable N_CL allocation.</td> </tr> <tr> <td></td> <td>1</td> <td>Enable N_CL allocation.</td> </tr> </table> | | | | | | | | N_CL Allocation Enable/Disable Selection | | n.X□□□ | 0 | Disable N_CL allocation. | | 1 | Enable N_CL allocation. | | | | | | | | | | | | | | | | | | | | | | | | | | | |
| N_CL Allocation Enable/Disable Selection | | | | | | | | | | | | | | | | | | | | | | | | | | | | | | | | | | | | | | | | | | | | |
| n.X□□□ | 0 | Disable N_CL allocation. | | | | | | | | | | | | | | | | | | | | | | | | | | | | | | | | | | | | | | | | | | |
| | 1 | Enable N_CL allocation. | | | | | | | | | | | | | | | | | | | | | | | | | | | | | | | | | | | | | | | | | | |

Continued on next page.

Continued from previous page.

| Parameter No. | Size | Name | Setting Range | Setting Unit | Default Setting | Applicable Motors | When Enabled | Classification | Reference | |
|------------------------|--|---|---|-------------------------------------|-----------------|-------------------|---------------|----------------|-----------|--|
| Pn82D M2 *15 | 2 | Option Field Allocations | 0000h to 1F1Ch | - | 0000h | All | After restart | Setup | *14 | |
| | | BANK_SEL1 Allocation (Option) | | | | | | | | |
| | | n.□□□X | 0 | Allocate bits 0 to 3 to BANK_SEL1. | | | | | | |
| | | | 1 | Allocate bits 1 to 4 to BANK_SEL1. | | | | | | |
| | | | 2 | Allocate bits 2 to 5 to BANK_SEL1. | | | | | | |
| | | | 3 | Allocate bits 3 to 6 to BANK_SEL1. | | | | | | |
| | | | 4 | Allocate bits 4 to 7 to BANK_SEL1. | | | | | | |
| | | | 5 | Allocate bits 5 to 8 to BANK_SEL1. | | | | | | |
| | | | 6 | Allocate bits 6 to 9 to BANK_SEL1. | | | | | | |
| | | | 7 | Allocate bits 7 to 10 to BANK_SEL1. | | | | | | |
| | | | 8 | Allocate bits 8 to 11 to BANK_SEL1. | | | | | | |
| | | | 9 | Allocate bits 9 to 12 to BANK_SEL1. | | | | | | |
| | | A | Allocate bits 10 to 13 to BANK_SEL1. | | | | | | | |
| | | B | Allocate bits 11 to 14 to BANK_SEL1. | | | | | | | |
| | | C | Allocate bits 12 to 15 to BANK_SEL1. | | | | | | | |
| | BANK_SEL1 Allocation Enable/Disable Selection | | | | | | | | | |
| | n.□□X□ | 0 | Disable BANK_SEL1 allocation. | | | | | | | |
| | | 1 | Enable BANK_SEL1 allocation. | | | | | | | |
| | LT_DISABLE Allocation (Option) | | | | | | | | | |
| | n.□X□□ | 0 to F | The settings are the same as for the V_PPI allocations. | | | | | | | |
| | | LT_DISABLE Allocation Enable/Disable Selection | | | | | | | | |
| | n.X□□□ | 0 | Disable LT_DISABLE allocation. | | | | | | | |
| | | 1 | Enable LT_DISABLE allocation. | | | | | | | |

Continued on next page.

Continued from previous page.

| Parameter No. | Size | Name | Setting Range | Setting Unit | Default Setting | Applicable Motors | When Enabled | Classification | Reference | |
|------------------------|--------|--|---|---|-----------------|-------------------|----------------|----------------|-----------|--|
| Pn82E M2 *15 | 2 | Option Field Allocations 5 | 0000h to 1D1Fh | - | 0000h | All | After restart | Setup | *14 | |
| | | n.□□□X | Reserved parameter (Do not change.) | | | | | | | |
| | | n.□□X□ | Reserved parameter (Do not change.) | | | | | | | |
| | | n.□X□□ | OUT_SIGNAL Allocation (Option) | | | | | | | |
| | | | 0 | Allocate bits 0 to 2 to OUT_SIGNAL. | | | | | | |
| | | | 1 | Allocate bits 1 to 3 to OUT_SIGNAL. | | | | | | |
| | | | 2 | Allocate bits 2 to 4 to OUT_SIGNAL. | | | | | | |
| | | | 3 | Allocate bits 3 to 5 to OUT_SIGNAL. | | | | | | |
| | | | 4 | Allocate bits 4 to 6 to OUT_SIGNAL. | | | | | | |
| | | | 5 | Allocate bits 5 to 7 to OUT_SIGNAL. | | | | | | |
| | | | 6 | Allocate bits 6 to 8 to OUT_SIGNAL. | | | | | | |
| | | | 7 | Allocate bits 7 to 9 to OUT_SIGNAL. | | | | | | |
| | | | 8 | Allocate bits 8 to 10 to OUT_SIGNAL. | | | | | | |
| | | 9 | Allocate bits 9 to 11 to OUT_SIGNAL. | | | | | | | |
| | | A | Allocate bits 10 to 12 to OUT_SIGNAL. | | | | | | | |
| | B | Allocate bits 11 to 13 to OUT_SIGNAL. | | | | | | | | |
| | C | Allocate bits 12 to 14 to OUT_SIGNAL. | | | | | | | | |
| | D | Allocate bits 13 to 15 to OUT_SIGNAL. | | | | | | | | |
| | n.X□□□ | OUT_SIGNAL Allocation Enable/Disable Selection | | | | | | | | |
| | | 0 | Disable OUT_SIGNAL allocation. | | | | | | | |
| | | 1 | Enable OUT_SIGNAL allocation. | | | | | | | |
| Pn833 | 2 | Motion Settings | 0000h to 0001h | - | 0000h | All | After restart | Setup | *2 | |
| | | n.□□□X | Linear Acceleration/Deceleration Constant Selection | | | | | | | |
| | | | 0 | Use Pn80A to Pn80F and Pn827. (The settings of Pn834 to Pn840 are ignored.) | | | | | | |
| | | | 1 | Use Pn834 to Pn840. (The settings of Pn80A to Pn80F and Pn827 are ignored.) | | | | | | |
| | | n.□□X□ | Reserved parameter (Do not change.) | | | | | | | |
| | | n.□X□□ | Reserved parameter (Do not change.) | | | | | | | |
| | n.X□□□ | Reserved parameter (Do not change.) | | | | | | | | |
| Pn834 | 4 | First Stage Linear Acceleration Constant 2 | 1 to 20,971,520 | 10,000 reference units/s ² | 100 | All | Immediately*12 | Setup | *2 | |
| Pn836 | 4 | Second Stage Linear Acceleration Constant 2 | 1 to 20,971,520 | 10,000 reference units/s ² | 100 | All | Immediately*12 | Setup | *2 | |
| Pn838 | 4 | Acceleration Constant Switching Speed 2 | 0 to 2,097,152,000 | 1 reference unit/s | 0 | All | Immediately*12 | Setup | *2 | |
| Pn83A | 4 | First Stage Linear Deceleration Constant 2 | 1 to 20,971,520 | 10,000 reference units/s ² | 100 | All | Immediately*12 | Setup | *2 | |

Continued on next page.

5.2.2 List of Servo Parameters

Continued from previous page.

| Parameter No. | Size | Name | Setting Range | Setting Unit | Default Setting | Applicable Motors | When Enabled | Classification | Reference | | | | | | | | | | | | |
|-----------------------------------|-----------------------------------|---|---|---------------------------------------|-----------------|-------------------|-----------------|----------------|-----------|-----------------------------------|-----------------------------------|--------|--------|---|---------|---|-------------|---|-------------|---|-------------|
| Pn83C | 4 | Second Stage Linear Deceleration Constant 2 | 1 to 20,971,520 | 10,000 reference units/s ² | 100 | All | Immediately *12 | Setup | *2 | | | | | | | | | | | | |
| Pn83E | 4 | Deceleration Constant Switching Speed 2 | 0 to 2,097,152,000 | 1 reference unit/s | 0 | All | Immediately *12 | Setup | *2 | | | | | | | | | | | | |
| Pn840 | 4 | Linear Deceleration Constant 2 for Stopping | 1 to 20,971,520 | 10,000 reference units/s ² | 100 | All | Immediately *12 | Setup | *2 | | | | | | | | | | | | |
| Pn842 *16 | 4 | Second Origin Approach Speed 1 | 0 to 20,971,520 | 100 reference units/s | 0 | All | Immediately *12 | Setup | *2 | | | | | | | | | | | | |
| Pn844 *17 | 4 | Second Origin Approach Speed 2 | 0 to 20,971,520 | 100 reference units/s | 0 | All | Immediately *12 | Setup | *2 | | | | | | | | | | | | |
| Pn846 | 2 | POSING Command Scurve Acceleration/Deceleration Rate | 0 to 50 | 1% | 0 | All | Immediately *12 | Setup | — | | | | | | | | | | | | |
| Pn850 | 2 | Number of Latch Sequences | 0 to 8 | — | 0 | All | Immediately | Setup | *2 | | | | | | | | | | | | |
| Pn851 | 2 | Continuous Latch Sequence Count | 0 to 255 | — | 0 | All | Immediately | Setup | *2 | | | | | | | | | | | | |
| Pn852 | 2 | Latch Sequence 1 to 4 Settings | 0000h to 3333h | — | 0000h | All | Immediately | Setup | *2 | | | | | | | | | | | | |
| | | | <table border="1"> <thead> <tr> <th colspan="2">Latch Sequence 1 Signal Selection</th> </tr> </thead> <tbody> <tr> <td rowspan="4">n.□□□X</td> <td>0</td> <td>Phase C</td> </tr> <tr> <td>1</td> <td>EXT1 signal</td> </tr> <tr> <td>2</td> <td>EXT2 signal</td> </tr> <tr> <td>3</td> <td>EXT3 signal</td> </tr> </tbody> </table> | | | | | | | | Latch Sequence 1 Signal Selection | | n.□□□X | 0 | Phase C | 1 | EXT1 signal | 2 | EXT2 signal | 3 | EXT3 signal |
| | Latch Sequence 1 Signal Selection | | | | | | | | | | | | | | | | | | | | |
| | n.□□□X | 0 | Phase C | | | | | | | | | | | | | | | | | | |
| | | 1 | EXT1 signal | | | | | | | | | | | | | | | | | | |
| 2 | | EXT2 signal | | | | | | | | | | | | | | | | | | | |
| 3 | | EXT3 signal | | | | | | | | | | | | | | | | | | | |
| | | <table border="1"> <thead> <tr> <th colspan="2">Latch Sequence 2 Signal Selection</th> </tr> </thead> <tbody> <tr> <td>n.□□□□</td> <td>0 to 3</td> <td>The settings are the same as those for the Latch Sequence 1 Signal Selection.</td> </tr> </tbody> </table> | | | | | | | | Latch Sequence 2 Signal Selection | | n.□□□□ | 0 to 3 | The settings are the same as those for the Latch Sequence 1 Signal Selection. | | | | | | | |
| Latch Sequence 2 Signal Selection | | | | | | | | | | | | | | | | | | | | | |
| n.□□□□ | 0 to 3 | The settings are the same as those for the Latch Sequence 1 Signal Selection. | | | | | | | | | | | | | | | | | | | |
| | | <table border="1"> <thead> <tr> <th colspan="2">Latch Sequence 3 Signal Selection</th> </tr> </thead> <tbody> <tr> <td>n.□X□□</td> <td>0 to 3</td> <td>The settings are the same as those for the Latch Sequence 1 Signal Selection.</td> </tr> </tbody> </table> | | | | | | | | Latch Sequence 3 Signal Selection | | n.□X□□ | 0 to 3 | The settings are the same as those for the Latch Sequence 1 Signal Selection. | | | | | | | |
| Latch Sequence 3 Signal Selection | | | | | | | | | | | | | | | | | | | | | |
| n.□X□□ | 0 to 3 | The settings are the same as those for the Latch Sequence 1 Signal Selection. | | | | | | | | | | | | | | | | | | | |
| | | <table border="1"> <thead> <tr> <th colspan="2">Latch Sequence 4 Signal Selection</th> </tr> </thead> <tbody> <tr> <td>n.X□□□</td> <td>0 to 3</td> <td>The settings are the same as those for the Latch Sequence 1 Signal Selection.</td> </tr> </tbody> </table> | | | | | | | | Latch Sequence 4 Signal Selection | | n.X□□□ | 0 to 3 | The settings are the same as those for the Latch Sequence 1 Signal Selection. | | | | | | | |
| Latch Sequence 4 Signal Selection | | | | | | | | | | | | | | | | | | | | | |
| n.X□□□ | 0 to 3 | The settings are the same as those for the Latch Sequence 1 Signal Selection. | | | | | | | | | | | | | | | | | | | |

Continued on next page.

Continued from previous page.

| Parameter No. | Size | Name | Setting Range | Setting Unit | Default Setting | Applicable Motors | When Enabled | Classification | Reference | | |
|---------------|------------------------|---|---|---|-----------------|-------------------|--------------|----------------|-----------|----|--|
| Pn853 | 2 | Latch Sequence 5 to 8 Settings | 0000h to 3333h | - | 0000h | All | Immediately | Setup | *2 | | |
| | n.□□□X | Latch Sequence 5 Signal Selection | | | | | | | | | |
| | | 0 | Phase C | | | | | | | | |
| | | 1 | EXT1 signal | | | | | | | | |
| | | 2 | EXT2 signal | | | | | | | | |
| | n.□□X□ | Latch Sequence 6 Signal Selection | | | | | | | | | |
| | | 0 to 3 | The settings are the same as those for the Latch Sequence 5 Signal Selection. | | | | | | | | |
| | n.□X□□ | Latch Sequence 7 Signal Selection | | | | | | | | | |
| | | 0 to 3 | The settings are the same as those for the Latch Sequence 5 Signal Selection. | | | | | | | | |
| | n.X□□□ | Latch Sequence 8 Signal Selection | | | | | | | | | |
| | | 0 to 3 | The settings are the same as those for the Latch Sequence 5 Signal Selection. | | | | | | | | |
| | Pn860 M3 *10 | 2 | SVCMD_IO Input Signal Monitor Allocations 1 | 0000h to 1717h | - | 0000h | All | Immediately | Setup | *2 | |
| | | n.□□□X | Input Signal Monitor Allocation for CN1-13 (SVCMD_IO) | | | | | | | | |
| | | | 0 | Allocate bit 24 (IO_STS1) to CN1-13 input signal monitor. | | | | | | | |
| | | | 1 | Allocate bit 25 (IO_STS2) to CN1-13 input signal monitor. | | | | | | | |
| 2 | | | Allocate bit 26 (IO_STS3) to CN1-13 input signal monitor. | | | | | | | | |
| 3 | | | Allocate bit 27 (IO_STS4) to CN1-13 input signal monitor. | | | | | | | | |
| 4 | | | Allocate bit 28 (IO_STS5) to CN1-13 input signal monitor. | | | | | | | | |
| 5 | | | Allocate bit 29 (IO_STS6) to CN1-13 input signal monitor. | | | | | | | | |
| 6 | | | Allocate bit 30 (IO_STS7) to CN1-13 input signal monitor. | | | | | | | | |
| n.□□X□ | | CN1-13 Input Signal Monitor Enable/Disable Selection | | | | | | | | | |
| | | 0 | Disable allocation for CN1-13 input signal monitor. | | | | | | | | |
| n.□X□□ | | Input Signal Monitor Allocation for CN1-7 (SVCMD_IO) | | | | | | | | | |
| | | 0 to 7 | The settings are the same as the CN1-13 allocations. | | | | | | | | |
| n.X□□□ | | CN1-7 Input Signal Monitor Enable/Disable Selection | | | | | | | | | |
| | | 0 | Disable allocation for CN1-7 input signal monitor. | | | | | | | | |
| | | 1 | Enable allocation for CN1-7 input signal monitor. | | | | | | | | |

Continued on next page.

5.2.2 List of Servo Parameters

Continued from previous page.

| Parameter No. | Size | Name | Setting Range | Setting Unit | Default Setting | Applicable Motors | When Enabled | Classification | Reference | |
|------------------------|---------------|---|---|--|-----------------|-------------------|--------------|----------------|-----------|--|
| Pn861 M3 *10 | 2 | SVCMD_IO Input Signal Monitor Allocations 2 | 0000h to 1717h | - | 0000h | All | Immediately | Setup | *2 | |
| | n.□□□X | | Input Signal Monitor Allocation for CN1-8 (SVCMD_IO) | | | | | | | |
| | | | 0 to 7 | The settings are the same as the CN1-13 allocations. | | | | | | |
| | n.□□X□ | | CN1-8 Input Signal Monitor Enable/Disable Selection | | | | | | | |
| | | | 0 | Disable allocation for CN1-8 input signal monitor. | | | | | | |
| | | | 1 | Enable allocation for CN1-8 input signal monitor. | | | | | | |
| | n.□X□□ | | Input Signal Monitor Allocation for CN1-9 (SVCMD_IO) | | | | | | | |
| | | | 0 to 7 | The settings are the same as the CN1-13 allocations. | | | | | | |
| | n.X□□□ | | CN1-9 Input Signal Monitor Enable/Disable Selection | | | | | | | |
| | | | 0 | Disable allocation for CN1-9 input signal monitor. | | | | | | |
| | | 1 | Enable allocation for CN1-9 input signal monitor. | | | | | | | |
| Pn862 M3 *10 | 2 | SVCMD_IO Input Signal Monitor Allocations 3 | 0000h to 1717h | - | 0000h | All | Immediately | Setup | *2 | |
| | n.□□□X | | Input Signal Monitor Allocation for CN1-10 (SVCMD_IO) | | | | | | | |
| | | | 0 to 7 | The settings are the same as the CN1-13 allocations. | | | | | | |
| | n.□□X□ | | CN1-10 Input Signal Monitor Enable/Disable Selection | | | | | | | |
| | | | 0 | Disable allocation for CN1-10 input signal monitor. | | | | | | |
| | | | 1 | Enable allocation for CN1-10 input signal monitor. | | | | | | |
| | n.□X□□ | | Input Signal Monitor Allocation for CN1-11 (SVCMD_IO) | | | | | | | |
| | | | 0 to 7 | The settings are the same as the CN1-13 allocations. | | | | | | |
| | n.X□□□ | | CN1-11 Input Signal Monitor Enable/Disable Selection | | | | | | | |
| | | | 0 | Disable allocation for CN1-11 input signal monitor. | | | | | | |
| | | 1 | Enable allocation for CN1-11 input signal monitor. | | | | | | | |
| Pn863 M3 *10 | 2 | SVCMD_IO Input Signal Monitor Allocations 4 | 0000h to 1717h | - | 0000h | All | Immediately | Setup | *2 | |
| | n.□□□X | | Input Signal Monitor Allocation for CN1-12 (SVCMD_IO) | | | | | | | |
| | | | 0 to 7 | The settings are the same as the CN1-13 allocations. | | | | | | |
| | n.□□X□ | | CN1-12 Input Signal Monitor Enable/Disable Selection | | | | | | | |
| | | | 0 | Disable allocation for CN1-12 input signal monitor. | | | | | | |
| | | | 1 | Enable allocation for CN1-12 input signal monitor. | | | | | | |
| | n.□X□□ | | Reserved parameter (Do not change.) | | | | | | | |
| n.X□□□ | | Reserved parameter (Do not change.) | | | | | | | | |

Continued on next page.

Continued from previous page.

| Parameter No. | Size | Name | Setting Range | Setting Unit | Default Setting | Applicable Motors | When Enabled | Classification | Reference | |
|------------------------|--------|---|--|---|-----------------|-------------------|--------------|----------------|-----------|--|
| Pn868 M3 *10 | 2 | SVCMD_IO Output Signal Monitor Allocations 1 | 0000h to 1717h | - | 0000h | All | Immediately | Setup | *2 | |
| | | | Output Signal Monitor Allocation for CN1-1 and CN1-2 (SVCMD_IO) | | | | | | | |
| | n.□□□X | | 0 | Allocate bit 24 (IO_STS1) to CN1-1/CN1-2 output signal monitor. | | | | | | |
| | | | 1 | Allocate bit 25 (IO_STS2) to CN1-1/CN1-2 output signal monitor. | | | | | | |
| | | | 2 | Allocate bit 26 (IO_STS3) to CN1-1/CN1-2 output signal monitor. | | | | | | |
| | | | 3 | Allocate bit 27 (IO_STS4) to CN1-1/CN1-2 output signal monitor. | | | | | | |
| | | | 4 | Allocate bit 28 (IO_STS5) to CN1-1/CN1-2 output signal monitor. | | | | | | |
| | | | 5 | Allocate bit 29 (IO_STS6) to CN1-1/CN1-2 output signal monitor. | | | | | | |
| | | | 6 | Allocate bit 30 (IO_STS7) to CN1-1/CN1-2 output signal monitor. | | | | | | |
| | | | 7 | Allocate bit 31 (IO_STS8) to CN1-1/CN1-2 output signal monitor. | | | | | | |
| | | | CN1-1/CN1-2 Output Signal Monitor Enable/Disable Selection | | | | | | | |
| | n.□□X□ | | 0 | Disable allocation for CN1-1/CN1-2 output signal monitor. | | | | | | |
| | | | 1 | Enable allocation for CN1-1/CN1-2 output signal monitor. | | | | | | |
| | | | Output Signal Monitor Allocation for CN1-23 and CN1-24 (SVCMD_IO) | | | | | | | |
| | n.□X□□ | | 0 to 7 | The settings are the same as the CN1-1/CN1-2 allocations. | | | | | | |
| | | CN1-23/CN1-24 Output Signal Monitor Enable/Disable Selection | | | | | | | | |
| n.X□□□ | | 0 | Disable allocation for CN1-23/CN1-24 output signal monitor. | | | | | | | |
| | | 1 | Enable allocation for CN1-23/CN1-24 output signal monitor. | | | | | | | |
| Pn869 M3 *10 | 2 | SVCMD_IO Output Signal Monitor Allocations 2 | 0000h to 1717h | - | 0000h | All | Immediately | Setup | *2 | |
| | n.□□□X | | 0 to 7 | The settings are the same as the CN1-1/CN1-2 allocations. | | | | | | |
| | | | CN1-25/CN1-26 Output Signal Monitor Enable/Disable Selection | | | | | | | |
| | n.□□X□ | | 0 | Disable allocation for CN1-25/CN1-26 output signal monitor. | | | | | | |
| | | | 1 | Enable allocation for CN1-25/CN1-26 output signal monitor. | | | | | | |
| | n.□X□□ | | Reserved parameter (Do not change.) | | | | | | | |
| n.X□□□ | | Reserved parameter (Do not change.) | | | | | | | | |
| Pn880 | 2 | Station Address Monitor (for maintenance, read only) | 03h to EFh | - | - | All | - | Setup | - | |
| Pn881 | 2 | Set Transmission Byte Count Monitor [bytes] (for maintenance, read only) | 17, 32, 48 | - | - | All | - | Setup | - | |
| Pn882 | 2 | Transmission Cycle Setting Monitor [$\times 0.25 \mu\text{s}$] (for maintenance, read only) | 0h to FFFFh | - | - | All | - | Setup | - | |
| Pn883 | 2 | Communications Cycle Setting Monitor [transmission cycles] (for maintenance, read only) | 0 to 32 | - | - | All | - | Setup | - | |

Continued on next page.

Continued from previous page.

| Parameter No. | Size | Name | Setting Range | Setting Unit | Default Setting | Applicable Motors | When Enabled | Classification | Reference | |
|------------------------|---|---|---|--------------|-----------------|-------------------|---------------|----------------|-----------|--|
| Pn884 M3 *10 | 2 | Communications Controls 2 | 0000h to 0001h | – | 0000h | All | Immediately | Setup | *2 | |
| | MECHATROLINK Communications Error Holding Brake Signal Setting | | | | | | | | | |
| | n.□□□X | 0 | Maintain the status set by the BRK_ON or BRK_OFF command when a MECHATROLINK communications error occurs. | | | | | | | |
| | | 1 | Apply the holding brake when a MECHATROLINK communications error occurs. | | | | | | | |
| | n.□□X□ | Reserved parameter (Do not change.) | | | | | | | | |
| | n.□X□□ | Reserved parameter (Do not change.) | | | | | | | | |
| n.X□□□ | Reserved parameter (Do not change.) | | | | | | | | | |
| Pn88A | 2 | MECHATROLINK Receive Error Counter Monitor (for maintenance, read only) | 0 to 65,535 | – | 0 | All | – | Setup | – | |
| Pn890 to Pn8A6 | 4 | Command Data Monitor during Alarm/Warning (for maintenance, read only) | 0h to FFFFFFFh | – | 0h | All | – | Setup | *2 | |
| Pn8A8 to Pn8BE | 4 | Response Data Monitor during Alarm/Warning (for maintenance, read only) | 0h to FFFFFFFh | – | 0h | All | – | Setup | *2 | |
| Pn900 | 2 | Number of Parameter Banks | 0 to 16 | – | 0 | All | After restart | Setup | *2 | |
| Pn901 | 2 | Number of Parameter Bank Members | 0 to 15 | – | 0 | All | After restart | Setup | *2 | |
| Pn902 to Pn910 | 2 | Parameter Bank Member Definition | 0000h to 08FFh | – | 0000h | All | After restart | Setup | *2 | |
| Pn920 to Pn95F | 2 | Parameter Bank Data (Not saved in nonvolatile memory.) | 0000h to FFFFh | – | 0000h | All | Immediately | Setup | *2 | |

- *1. Refer to the following manual for details.
 Σ-7-Series Σ-7S SERVOPACK with MECHATROLINK-III Communications References Product Manual (Manual No.: SIEP S800001 28)
- *2. Refer to the following manual for details.
 Σ-7-Series MECHATROLINK-III Communications Standard Servo Profile Command Manual (Manual No.: SIEP S800001 31)
- *3. Set a percentage of the motor rated torque.
- *4. These parameters are for SERVOPACKs with a Safety Module. Refer to the following manual for details.
 Σ-V-Series/Σ-V-Series for Large-Capacity Models/Σ-7-Series User's Manual Safety Module (Manual No.: SIEP C720829 06)
- *5. Normally set this parameter to 0. If you use an External Regenerative Resistor, set the capacity (W) of the External Regenerative Resistor.
- *6. The upper limit is the maximum output capacity (W) of the SERVOPACK.
- *7. These parameters are for SERVOPACKs with the dynamic brake option. Refer to the following manual for details.
 Σ-7-Series Σ-7S/Σ-7W SERVOPACK with Hardware Option Specifications Dynamic Brake Product Manual (Manual No.: SIEP S800001 73)
- *8. The SGLFW2 is the only Yaskawa Linear Servomotor that supports this function.
- *9. Enabled only when Pn61A is set to n.□□□2 or n.□□□3.
- *10. This parameter is valid only when the MECHATROLINK-III standard servo profile is used.
- *11. The parameter setting is enabled after SENS_ON command execution is completed.
- *12. Change the setting when the reference is stopped (i.e., while DEN is set to 1). If you change the setting during operation, the reference output will be affected.
- *13. The settings are updated only if the reference is stopped (i.e., only if DEN is set to 1).
- *14. Refer to the following manual for details.
 Σ-7-Series AC Servo Drive MECHATROLINK-II Communications Command Manual (Manual No.: SIEP S800001 30)
- *15. This parameter is valid only when the MECHATROLINK-II-compatible profile is used.
- *16. The setting of Pn842 is valid while Pn817 is set to 0.
- *17. The setting of Pn844 is valid while Pn818 is set to 0.
- *18. You can check overspeed detection speed with MECHATROLINK-III Common Parameter 05 PnA0A (Maximum Output Speed).

5.2.3 List of MECHATROLINK-III Common Parameters

The following table lists the common MECHATROLINK-III parameters. These common parameters are used to make settings from the host controller via MECHATROLINK communications. Do not change the settings with the Digital Operator or any other device.

| Parameter No. | Size | Name | Setting Range | Setting Unit [Resolution] | Default Setting | Applicable Motors | When Enabled | Classification |
|---------------|------|--|---------------------------------|---------------------------|-----------------|-------------------|-----------------|--------------------|
| 01 PnA02 | 4 | Encoder Type Selection (read only) | 0h, 1h | – | – | All | – | Device information |
| | | 0000h | Absolute encoder | | | | | |
| | | 0001h | Incremental encoder | | | | | |
| 02 PnA04 | 4 | Motor Type Selection (read only) | 0h, 1h | – | – | All | – | |
| | | 0000h | Rotary Servomotor | | | | | |
| | | 0001h | Linear Servomotor | | | | | |
| 03 PnA06 | 4 | Semi-closed/Fully-closed Selection (read only) | 0h, 1h | – | – | All | – | |
| | | 0000h | Semi-closed | | | | | |
| | | 0001h | Fully-closed | | | | | |
| 04 PnA08 | 4 | Rated Motor Speed (read only) | 0h to FFFFFFFFh | 1 min ⁻¹ | – | All | – | |
| 05 PnA0A | 4 | Maximum Output Speed (read only) | 0h to FFFFFFFFh | 1 min ⁻¹ | – | All | – | |
| 06 PnA0C | 4 | Speed Multiplier (read only) | -1,073,741,823 to 1,073,741,823 | – | – | All | – | |
| 07 PnA0E | 4 | Rated Torque (read only) | 0h to FFFFFFFFh | 1 N·m | – | All | – | |
| 08 PnA10 | 4 | Maximum Output Torque (read only) | 0h to FFFFFFFFh | 1 N·m | – | All | – | |
| 09 PnA12 | 4 | Torque Multiplier (read only) | -1,073,741,823 to 1,073,741,823 | – | – | All | – | |
| 0A PnA14 | 4 | Resolution (read only) | 0h to FFFFFFFFh | 1 pulse/rev | – | Rotary | – | |
| 0B PnA16 | 4 | Scale Pitch | 0 to 65,536,000 | 1 nm [0.01 μm] | 0 | Linear | After restart*1 | |
| 0C PnA18 | 4 | Pulses per Scale Pitch (read only) | 0h to FFFFFFFFh | 1 pulse/pitch | – | Linear | – | |

Continued on next page.

5.2 SERVOPACKs with MECHATROLINK-III Communications References

5.2.3 List of MECHATROLINK-III Common Parameters

Continued from previous page.

| Parameter No. | Size | Name | Setting Range | Setting Unit [Resolution] | Default Setting | Applicable Motors | When Enabled | Classification | |
|---------------|-----------|--|---------------------------------|---------------------------|-----------------|-------------------|---------------|------------------------|--|
| 21 PnA42 | 4 | Electronic Gear Ratio (Numerator) | 1 to 1,073,741,824 | - | 16 | All | After restart | Machine specifications | |
| 22 PnA44 | 4 | Electronic Gear Ratio (Denominator) | 1 to 1,073,741,824 | - | 1 | All | After restart | | |
| 23 PnA46 | 4 | Absolute Encoder Origin Offset | -1,073,741,823 to 1,073,741,823 | 1 reference unit | 0 | All | Immediately*1 | | |
| 24 PnA48 | 4 | Multiturn Limit Setting | 0 to 65,535 | 1 Rev | 65535 | Rotary | After restart | | |
| 25 PnA4A | 4 | Limit Setting | 0h to 33h | - | 0000h | All | After restart | | |
| | | Bit 0 | P-OT (0: Enabled, 1: Disabled) | | | | | | |
| | | Bit 1 | N-OT (0: Enabled, 1: Disabled) | | | | | | |
| | | Bit 2 | Reserved. | | | | | | |
| | | Bit 3 | Reserved. | | | | | | |
| | | Bit 4 | P-SOT (0: Disabled, 1: Enabled) | | | | | | |
| | | Bit 5 | N-SOT (0: Disabled, 1: Enabled) | | | | | | |
| Bits 6 to 31 | Reserved. | | | | | | | | |
| 26 PnA4C | 4 | Forward Software Limit | -1,073,741,823 to 1,073,741,823 | 1 reference unit | 1073741823 | All | Immediately | | |
| 27 PnA4E | 4 | Reserved parameter (Do not change.) | - | - | 0 | All | Immediately | | |
| 28 PnA50 | 4 | Reverse Software Limit | -1,073,741,823 to 1,073,741,823 | 1 reference unit | -1073741823 | All | Immediately | | |
| 29 PnA52 | 4 | Reserved parameter (Do not change.) | - | - | 0 | All | Immediately | | |
| 41 PnA82 | 4 | Speed Unit Selection*2 | 0h to 4h | - | 0h | All | After restart | | |
| | | 0000h | Reference units/s | | | | | | |
| | | 0001h | Reference units/min | | | | | | |
| | | 0002h | Percentage (%) of rated speed*3 | | | | | | |
| | | 0003h | min ^{-1*3} | | | | | | |
| | | 0004h | Maximum motor speed/4000000h*4 | | | | | | |
| 42 PnA84 | 4 | Speed Base Unit Selection*3,*4 (Set the value of n from the following formula: Speed unit selection (41 PnA82) × 10 ⁿ) | -3 to 3 | - | 0 | All | After restart | Unit settings | |
| 43 PnA86 | 4 | Position Unit Selection | 0h | - | 0h | All | After restart | | |
| | | 0000h | Reference units | | | | | | |

Continued on next page.

Continued from previous page.

| Parameter No. | Size | Name | Setting Range | Setting Unit [Resolution] | Default Setting | Applicable Motors | When Enabled | Classification | |
|---------------|------|--|--|---------------------------|-----------------|-------------------|---------------|----------------|--|
| 44 PnA88 | 4 | Position Base Unit Selection (Set the value of n from the following formula: Position unit selection (43 PnA86) × 10 ⁿ) | 0 | - | 0 | All | After restart | Unit settings | |
| 45 PnA8A | 4 | Acceleration Unit Selection | 0h | - | 0h | All | After restart | | |
| | | 0000h | Reference units/s ² | | | | | | |
| 46 PnA8C | 4 | Acceleration Base Unit Selection (Set the value of n from the following formula: Acceleration unit selection (45 PnA8A) × 10 ⁿ) | 4 to 6 | - | 4 | All | After restart | | |
| 47 PnA8E | 4 | Torque Unit Selection | 1h, 2h | - | 1h | All | After restart | | |
| | | 0001h | Percentage (%) of rated torque | | | | | | |
| | | 0002h | Maximum torque/4000000h*5 | | | | | | |
| 48 PnA90 | 4 | Torque Base Unit Selection*5 (Set the value of n from the following formula: Torque unit selection (47 PnA8E) × 10 ⁿ) | -5 to 0 | - | 0 | All | After restart | | |
| 49 PnA92 | 4 | Supported Unit Systems (read only) | - | - | 0601011Fh | All | - | | |
| | | Speed Units | | | | | | | |
| | | Bit 0 | Reference units/s (1: Enabled) | | | | | | |
| | | Bit 1 | Reference units/min (1: Enabled) | | | | | | |
| | | Bit 2 | Percentage (%) of rated speed (1: Enabled) | | | | | | |
| | | Bit 3 | min ⁻¹ (rpm) (1: Enabled) | | | | | | |
| | | Bit 4 | Maximum motor speed/4000000h (1: Enabled) | | | | | | |
| | | Bits 5 to 7 | Reserved (0: Disabled). | | | | | | |
| | | Position Units | | | | | | | |
| | | Bit 8 | Reference units (1: Enabled) | | | | | | |
| | | Bits 9 to 15 | Reserved (0: Disabled). | | | | | | |
| | | Acceleration Units | | | | | | | |
| | | Bit 16 | Reference units/s ² (1: Enabled) | | | | | | |
| | | Bit 17 | ms (acceleration time required to reach rated speed) (0: Disabled) | | | | | | |
| | | Bits 18 to 23 | Reserved (0: Disabled). | | | | | | |
| | | Torque Units | | | | | | | |
| | | Bit 24 | N·m (0: Disabled) | | | | | | |
| | | Bit 25 | Percentage (%) of rated torque (1: Enabled) | | | | | | |
| | | Bit 26 | Maximum torque/40000000h (1: Enabled) | | | | | | |
| | | Bits 27 to 31 | Reserved (0: Disabled). | | | | | | |

Continued on next page.

5.2 SERVOPACKs with MECHATROLINK-III Communications References

5.2.3 List of MECHATROLINK-III Common Parameters

Continued from previous page.

| Parameter No. | Size | Name | Setting Range | Setting Unit [Resolution] | Default Setting | Applicable Motors | When Enabled | Classification |
|---------------|-------|---|---------------------------------|------------------------------------|---|-------------------|---------------|----------------|
| 61 PnAC2 | 4 | Speed Loop Gain | 1,000 to 2,000,000 | 0.001 Hz [0.1 Hz] | 40000 | All | Immediately | Tuning |
| 62 PnAC4 | 4 | Speed Loop Integral Time Constant | 150 to 512,000 | 1 μ s [0.01 ms] | 20000 | All | Immediately | |
| 63 PnAC6 | 4 | Position Loop Gain | 1,000 to 2,000,000 | 0.001/s [0.1/s] | 40000 | All | Immediately | |
| 64 PnAC8 | 4 | Feedforward Compensation | 0 to 100 | 1% | 0 | All | Immediately | |
| 65 PnACA | 4 | Position Loop Integral Time Constant | 0 to 5,000,000 | 1 μ s [0.1 ms] | 0 | All | Immediately | |
| 66 PnACC | 4 | Positioning Completed Width | 0 to 1,073,741,824 | 1 reference unit | 7 | All | Immediately | |
| 67 PnACE | 4 | Near Signal Width | 1 to 1,073,741,824 | 1 reference unit | 1073741824 | All | Immediately | |
| 81 PnB02 | 4 | Exponential Acceleration/Deceleration Time Constant | 0 to 510,000 | 1 μ s [0.1 ms] | 0 | All | Immediately*6 | |
| 82 PnB04 | 4 | Movement Average Time | 0 to 510,000 | 1 μ s [0.1 ms] | 0 | All | Immediately*6 | |
| 83 PnB06 | 4 | External Positioning Final Travel Distance | -1,073,741,823 to 1,073,741,823 | 1 reference unit | 100 | All | Immediately | |
| 84 PnB08 | 4 | Origin Approach Speed | 0h to 3FFFFFFh | 10 ⁻³ min ⁻¹ | \times 5,000h reference units/s converted to 10 ⁻³ min ⁻¹ | All | Immediately | |
| 85 PnB0A | 4 | Origin Return Creep Speed | 0h to 3FFFFFFh | 10 ⁻³ min ⁻¹ | \times 500h reference units/s converted to 10 ⁻³ min ⁻¹ | All | Immediately | |
| 86 PnB0C | 4 | Final Travel Distance for Origin Return | -1,073,741,823 to 1,073,741,823 | 1 reference unit | 100 | All | Immediately | |
| 87 PnB0E | 4 | Fixed Monitor Selection 1 | 0h to Fh | - | 1h | All | Immediately | |
| | | 0000h | APOS | | | | | |
| | | 0001h | CPOS | | | | | |
| | | 0002h | PERR | | | | | |
| | | 0003h | LPOS1 | | | | | |
| | | 0004h | LPOS2 | | | | | |
| | | 0005h | FSPD | | | | | |
| | | 0006h | CSPD | | | | | |
| | | 0007h | TRQ | | | | | |
| | | 0008h | ALARM | | | | | |
| | | 0009h | MPOS | | | | | |
| | | 000Ah | Reserved (undefined value). | | | | | |
| | | 000Bh | Reserved (undefined value). | | | | | |
| | | 000Ch | CMN1 (common monitor 1) | | | | | |
| | | 000Dh | CMN2 (common monitor 2) | | | | | |
| | | 000Eh | OMN1 (optional monitor 1) | | | | | |
| | 000Fh | OMN2 (optional monitor 2) | | | | | | |

Continued on next page.

Continued from previous page.

| Parameter No. | Size | Name | Setting Range | Setting Unit [Resolution] | Default Setting | Applicable Motors | When Enabled | Classification | | | |
|---------------|-------------------|------------------------------------|---|---|---|-------------------|---|----------------------------|--|--|--|
| 88 PnB10 | 4 | Fixed Monitor Selection 2 | 0h to Fh | - | 0h | All | Immediately | | | | |
| | | 0000h to 000Fh | The settings are the same as those for Fixed Monitor Selection 1. | | | | | | | | |
| 89 PnB12 | 4 | SEL_MON (CMN1) Monitor Selection 1 | 0h to 9h | - | 0h | All | Immediately | Command-related parameters | | | |
| | | 0000h | TPOS (target position in reference coordinate system) | | | | | | | | |
| | | 0001h | IPOS (reference position in reference coordinate system) | | | | | | | | |
| | | 0002h | POS_OFFSET (offset set in POS_SET (Set Coordinate System) command) | | | | | | | | |
| | | 0003h | TSPD (target speed) | | | | | | | | |
| | | 0004h | SPD_LIM (speed limit) | | | | | | | | |
| | | 0005h | TRQ_LIM (torque limit) | | | | | | | | |
| | | 0006h | SV_STAT (servo actual operating status) Monitor Description Byte 1: Current communications phase 00h: Phase 0 01h: Phase 1 02h: Phase 2 03h: Phase 3 Byte 2: Current control mode 00h: Position control mode 01h: Speed control mode 02h: Torque control mode Byte 3: Reserved Byte 4: Expansion signal monitor | | | | | | | | |
| | | | Bit 0 | LT_RDY1 | Processing status for latch detection for LT_REQ1 in SVCM-D_CTRL region | 0 | Latch detection not yet processed. | | | | |
| | | | | | | 1 | Processing latch detection in progress. | | | | |
| | | | Bit 1 | LT_RDY1 | Processing status for latch detection for LT_REQ2 in SVCM-D_CTRL region | 0 | Latch detection not yet processed. | | | | |
| | | | | | | 1 | Processing latch detection in progress. | | | | |
| | | | Bits 2 and 3 | LT_SEL1R | Latch signal | 0 | Phase C | | | | |
| | | | | | | 1 | External input signal 1 | | | | |
| | | | | | | 2 | External input signal 2 | | | | |
| Bits 4 and 5 | LT_SEL2R | | Latch signal | 0 | Phase C | | | | | | |
| | | | | 1 | External input signal 1 | | | | | | |
| | | 2 | | External input signal 2 | | | | | | | |
| Bit 6 | Reserved (0). | | | | | | | | | | |
| 0007h | Reserved. | | | | | | | | | | |
| 0008h | INIT_PGPOS (Low) | | | Lower 32 bits of initial encoder position converted to 64-bit position reference data | | | | | | | |
| 0009h | INIT_PGPOS (High) | | | Upper 32 bits of initial encoder position converted to 64-bit position reference data | | | | | | | |

Continued on next page.

5.2.3 List of MECHATROLINK-III Common Parameters

Continued from previous page.

| Parameter No. | Size | Name | Setting Range | Setting Unit [Resolution] | Default Setting | Applicable Motors | When Enabled | Classification | | |
|---------------|-------------------------|---|---|------------------------------------|-----------------|-------------------|--------------|----------------------------|--|--|
| 8A PnB14 | 4 | SEL_MON (CMN2) Monitor Selection 2 | 0h to 9h | – | 0h | All | Immediately | Command-related parameters | | |
| | | 0000h to 0009h | The settings are the same as those for SEL_MON Monitor Selection 1. | | | | | | | |
| 8B PnB16 | 4 | Origin Detection Width | 0 to 250 | 1 reference unit | 10 | All | Immediately | | | |
| 8C PnB18 | 4 | Forward Torque Limit | 0 to 800 | 1% | 100 | All | Immediately | | | |
| 8D PnB1A | 4 | Reverse Torque Limit | 0 to 800 | 1% | 100 | All | Immediately | | | |
| 8E PnB1C | 4 | Zero Speed Detection Range | 1,000 to 10,000,000 | 10 ⁻³ min ⁻¹ | 20000 | All | Immediately | | | |
| 8F PnB1E | 4 | Speed Coincidence Signal Detection Width | 0 to 100,000 | 10 ⁻³ min ⁻¹ | 10000 | All | Immediately | | | |
| 90 PnB20 | 4 | Servo Command Control Field Enable/Disable Selections (read only) | – | – | 0FFF3F3Fh | All | – | | | |
| | | Bit 0 | CMD_PAUSE (1: Enabled) | | | | | | | |
| | | Bit 1 | CMD_CANCEL (1: Enabled) | | | | | | | |
| | | Bits 2 and 3 | STOP_MODE (1: Enabled) | | | | | | | |
| | | Bits 4 and 5 | ACCFIL (1: Enabled) | | | | | | | |
| | | Bits 6 and 7 | Reserved (0: Disabled). | | | | | | | |
| | | Bit 8 | LT_REQ1 (1: Enabled) | | | | | | | |
| | | Bit 9 | LT_REQ2 (1: Enabled) | | | | | | | |
| | | Bits 10 and 11 | LT_SEL1 (1: Enabled) | | | | | | | |
| | | Bits 12 and 13 | LT_SEL2 (1: Enabled) | | | | | | | |
| | | Bits 14 and 15 | Reserved (0: Disabled). | | | | | | | |
| | | Bits 16 to 19 | SEL_MON1 (1: Enabled) | | | | | | | |
| | | Bits 20 to 23 | SEL_MON2 (1: Enabled) | | | | | | | |
| | | Bits 24 to 27 | SEL_MON3 (1: Enabled) | | | | | | | |
| Bits 28 to 31 | Reserved (0: Disabled). | | | | | | | | | |

Continued on next page.

Continued from previous page.

| Parameter No. | Size | Name | Setting Range | Setting Unit [Resolution] | Default Setting | Applicable Motors | When Enabled | Classification |
|---------------|-------------------------|--|-----------------------------|---------------------------|-----------------------|-------------------|--------------|----------------------------|
| 91 PnB22 | 4 | Servo Status Field Enable/Disable Selections (read only) | - | - | - | All | - | Command-related parameters |
| | | Bit 0 | CMD_PAUSE_CMP (1: Enabled) | | | | | |
| | | Bit 1 | CMD_CANCEL_CMP (1: Enabled) | | | | | |
| | | Bit 2 and 3 | Reserved (0: Disabled). | | | | | |
| | | Bits 4 and 5 | ACCFIL (1: Enabled) | | | | | |
| | | Bits 6 and 7 | Reserved (0: Disabled). | | | | | |
| | | Bit 8 | L_CMP1 (1: Enabled) | | | | | |
| | | Bit 9 | L_CMP2 (1: Enabled) | | | | | |
| | | Bit 10 | POS_RDY (1: Enabled) | | | | | |
| | | Bit 11 | PON (1: Enabled) | | | | | |
| | | Bit 12 | M_RDY (1: Enabled) | | | | | |
| | | Bit 13 | SV_ON (1: Enabled) | | | | | |
| | | Bits 14 and 15 | Reserved (0: Disabled). | | | | | |
| | | Bits 16 to 19 | SEL_MON1 (1: Enabled) | | | | | |
| | | Bits 20 to 23 | SEL_MON2 (1: Enabled) | | | | | |
| Bits 24 to 27 | SEL_MON3 (1: Enabled) | | | | | | | |
| Bits 28 to 31 | Reserved (0: Disabled). | | | | | | | |
| 92 PnB24 | 4 | Output Bit Enable/Disable Selections (read only) | - | - | 007F01F0 _h | All | - | Command-related parameters |
| | | Bits 0 to 3 | Reserved (0: Disabled). | | | | | |
| | | Bit 4 | V_PPI (1: Enabled) | | | | | |
| | | Bit 5 | P_PPI (1: Enabled) | | | | | |
| | | Bit 6 | P_CL (1: Enabled) | | | | | |
| | | Bit 7 | N_CL (1: Enabled) | | | | | |
| | | Bit 8 | G_SEL (1: Enabled) | | | | | |
| | | Bits 9 to 11 | G_SEL (0: Disabled) | | | | | |
| | | Bits 12 to 15 | Reserved (0: Disabled). | | | | | |
| | | Bits 16 to 19 | BANK_SEL (1: Enabled) | | | | | |
| | | Bits 20 to 22 | SO1 to SO3 (1: Enabled) | | | | | |
| | | Bit 23 | Reserved (0: Disabled). | | | | | |
| | | Bits 24 to 31 | Reserved (0: Disabled). | | | | | |

Continued on next page.

5.2.3 List of MECHATROLINK-III Common Parameters

Continued from previous page.

| Parameter No. | Size | Name | Setting Range | Setting Unit [Resolution] | Default Setting | Applicable Motors | When Enabled | Classification | | |
|---------------|--------|---|-------------------------|---------------------------|-----------------|-------------------|--------------|----------------------------|--|--|
| 93 PnB26 | 4 | Input Bit Enable/Disable Selections (read only) | - | - | FF0FFEFh | All | - | Command-related parameters | | |
| | Bit 0 | | Reserved (0: Disabled). | | | | | | | |
| | Bit 1 | | DEC (1: Enabled) | | | | | | | |
| | Bit 2 | | P-OT (1: Enabled) | | | | | | | |
| | Bit 3 | | N-OT (1: Enabled) | | | | | | | |
| | Bit 4 | | EXT1 (1: Enabled) | | | | | | | |
| | Bit 5 | | EXT2 (1: Enabled) | | | | | | | |
| | Bit 6 | | EXT3 (1: Enabled) | | | | | | | |
| | Bit 7 | | ESTP (1: Enabled) | | | | | | | |
| | Bit 8 | | Reserved (0: Disabled). | | | | | | | |
| | Bit 9 | | BRK_ON (1: Enabled) | | | | | | | |
| | Bit 10 | | P-SOT (1: Enabled) | | | | | | | |
| | Bit 11 | | N-SOT (1: Enabled) | | | | | | | |
| | Bit 12 | | DEN (1: Enabled) | | | | | | | |
| | Bit 13 | | NEAR (1: Enabled) | | | | | | | |
| | Bit 14 | | PSET (1: Enabled) | | | | | | | |
| | Bit 15 | | ZPOINT (1: Enabled) | | | | | | | |
| | Bit 16 | | T_LIM (1: Enabled) | | | | | | | |
| | Bit 17 | | V_LIM (1: Enabled) | | | | | | | |
| | Bit 18 | | V_CMP (1: Enabled) | | | | | | | |
| | Bit 19 | | ZSPD (1: Enabled) | | | | | | | |
| Bits 20 to 23 | | Reserved (0: Disabled). | | | | | | | | |
| Bits 24 to 31 | | IO_STS1 to IO_STS8 (1: Enabled) | | | | | | | | |

- *1. The parameter setting is enabled after SENS_ON command execution is completed.
- *2. When using fully-closed loop control, set the reference units/s.
- *3. If you set the Speed Unit Selection (parameter 41) to either 0002h or 0003h, set the Speed Base Unit Selection (parameter 42) to a number between -3 and 0.
- *4. If you set the Speed Unit Selection (parameter 41) to 0004h, set the Speed Base Unit Selection (parameter 42) to 0.
- *5. If you set the Torque Unit Selection (parameter 47) to 0002h, set the Torque Base Unit Selection (parameter 48) to 0.
- *6. Change the setting when the reference is stopped (i.e., while DEN is set to 1). If you change the setting during operation, the reference output will be affected.

5.2.4 Parameter Recording Table

Use the following table to record the settings of the parameters.

| Parameter No. | Default Setting | | | | Name | When Enabled |
|---------------|-----------------|--|--|--|---|---------------|
| Pn000 | 0000h | | | | Basic Function Selections 0 | After restart |
| Pn001 | 0000h | | | | Application Function Selections 1 | After restart |
| Pn002 | 0011h | | | | Application Function Selections 2 | After restart |
| Pn006 | 0002h | | | | Application Function Selections 6 | Immediately |
| Pn007 | 0000h | | | | Application Function Selections 7 | Immediately |
| Pn008 | 4000h | | | | Application Function Selections 8 | After restart |
| Pn009 | 0010h | | | | Application Function Selections 9 | After restart |
| Pn00A | 0001h | | | | Application Function Selections A | After restart |
| Pn00B | 0000h | | | | Application Function Selections B | After restart |
| Pn00C | 0000h | | | | Application Function Selections C | After restart |
| Pn00D | 0000h | | | | Application Function Selections D | After restart |
| Pn00F | 0000h | | | | Application Function Selections F | After restart |
| Pn021 | 0000h | | | | Reserved parameter | – |
| Pn022 | 0000h | | | | Reserved parameter | – |
| Pn040 | 0000h | | | | Σ -V Compatible Function Switch | After restart |
| Pn080 | 0000h | | | | Application Function Selections 80 | After restart |
| Pn081 | 0000h | | | | Application Function Selections 81 | After restart |
| Pn100 | 400 | | | | Speed Loop Gain | Immediately |
| Pn101 | 2000 | | | | Speed Loop Integral Time Constant | Immediately |
| Pn102 | 400 | | | | Position Loop Gain | Immediately |
| Pn103 | 100 | | | | Moment of Inertia Ratio | Immediately |
| Pn104 | 400 | | | | Second Speed Loop Gain | Immediately |
| Pn105 | 2000 | | | | Second Speed Loop Integral Time Constant | Immediately |
| Pn106 | 400 | | | | Second Position Loop Gain | Immediately |
| Pn109 | 0 | | | | Feedforward | Immediately |
| Pn10A | 0 | | | | Feedforward Filter Time Constant | Immediately |
| Pn10B | 0004h | | | | Gain Application Selections | *1 |
| Pn10C | 200 | | | | Mode Switching Level for Torque Reference | Immediately |
| Pn10D | 0 | | | | Mode Switching Level for Speed Reference | Immediately |
| Pn10E | 0 | | | | Mode Switching Level for Acceleration | Immediately |
| Pn10F | 0 | | | | Mode Switching Level for Position Deviation | Immediately |

Continued on next page.

5.2.4 Parameter Recording Table

Continued from previous page.

| Parameter No. | Default Setting | | | | | Name | When Enabled |
|---------------|-----------------|--|--|--|--|---|---------------|
| Pn11F | 0 | | | | | Position Integral Time Constant | Immediately |
| Pn121 | 100 | | | | | Friction Compensation Gain | Immediately |
| Pn122 | 100 | | | | | Second Friction Compensation Gain | Immediately |
| Pn123 | 0 | | | | | Friction Compensation Coefficient | Immediately |
| Pn124 | 0 | | | | | Friction Compensation Frequency Correction | Immediately |
| Pn125 | 100 | | | | | Friction Compensation Gain Correction | Immediately |
| Pn131 | 0 | | | | | Gain Switching Time 1 | Immediately |
| Pn132 | 0 | | | | | Gain Switching Time 2 | Immediately |
| Pn135 | 0 | | | | | Gain Switching Waiting Time 1 | Immediately |
| Pn136 | 0 | | | | | Gain Switching Waiting Time 2 | Immediately |
| Pn139 | 0000h | | | | | Automatic Gain Switching Selections 1 | Immediately |
| Pn13D | 2000 | | | | | Current Gain Level | Immediately |
| Pn13F | 0 | | | | | Less-Deviation Control 2 Second Position Integral Time Constant | Immediately |
| Pn140 | 0100h | | | | | Model Following Control-Related Selections | Immediately |
| Pn141 | 500 | | | | | Model Following Control Gain | Immediately |
| Pn142 | 1000 | | | | | Model Following Control Gain Correction | Immediately |
| Pn143 | 1000 | | | | | Model Following Control Bias in the Forward Direction | Immediately |
| Pn144 | 1000 | | | | | Model Following Control Bias in the Reverse Direction | Immediately |
| Pn145 | 500 | | | | | Vibration Suppression 1 Frequency A | Immediately |
| Pn146 | 700 | | | | | Vibration Suppression 1 Frequency B | Immediately |
| Pn147 | 1000 | | | | | Model Following Control Speed Feedforward Compensation | Immediately |
| Pn148 | 500 | | | | | Second Model Following Control Gain | Immediately |
| Pn149 | 1000 | | | | | Second Model Following Control Gain Correction | Immediately |
| Pn14A | 800 | | | | | Vibration Suppression 2 Frequency | Immediately |
| Pn14B | 100 | | | | | Vibration Suppression 2 Correction | Immediately |
| Pn14F | 0021h | | | | | Control-Related Selections | After restart |
| Pn160 | 0010h | | | | | Anti-Resonance Control-Related Selections | Immediately |
| Pn161 | 1000 | | | | | Anti-Resonance Frequency | Immediately |
| Pn162 | 100 | | | | | Anti-Resonance Gain Correction | Immediately |

Continued on next page.

Continued from previous page.

| Parameter No. | Default Setting | | | | | Name | When Enabled |
|---------------|-----------------|--|--|--|--|--|---------------|
| Pn163 | 0 | | | | | Anti-Resonance Damping Gain | Immediately |
| Pn164 | 0 | | | | | Anti-Resonance Filter Time Constant 1 Correction | Immediately |
| Pn165 | 0 | | | | | Anti-Resonance Filter Time Constant 2 Correction | Immediately |
| Pn166 | 0 | | | | | Anti-Resonance Damping Gain 2 | Immediately |
| Pn170 | 1400h | | | | | Tuning-less Function-Related Selections | *1 |
| Pn181 | 0 | | | | | Mode Switching Level for Speed Reference | Immediately |
| Pn182 | 0 | | | | | Mode Switching Level for Acceleration | Immediately |
| Pn190 | 0100h | | | | | Less-Deviation Control-Related Switches | After restart |
| Pn191 | 1000 | | | | | Less-Deviation Control 1 Feedforward Gain | Immediately |
| Pn192 | 1000 | | | | | Less-Deviation Control 1 Second Feedforward Gain | Immediately |
| Pn193 | 30 | | | | | Less-Deviation Control 1 Feedforward Filter Time Constant | Immediately |
| Pn195 | 2102h | | | | | Less-Deviation Function Selection Switches | After restart |
| Pn196 | 1000 | | | | | Less-Deviation Control 2 Speed Feedforward Gain | Immediately |
| Pn197 | 50 | | | | | Less-Deviation Control 2 Torque Feedforward Filter Time Constant | Immediately |
| Pn198 | 1000 | | | | | Less-Deviation Control 2 Forward Torque Feedforward Gain | Immediately |
| Pn199 | 1000 | | | | | Less-Deviation Control 2 Reverse Torque Feedforward Gain | Immediately |
| Pn19A | 10000 | | | | | Less-Deviation Control 2 Incomplete Integration Rate | Immediately |
| Pn19B | 0 | | | | | Less-Deviation Control 2 Rotary Servomotor Viscous Friction Compensation Coefficient | Immediately |
| Pn19C | 0 | | | | | Reserved parameter | Immediately |
| Pn19D | 0 | | | | | Less-Deviation Control 2 Linear Servomotor Viscous Friction Compensation Coefficient | Immediately |
| Pn19E | 0 | | | | | Reserved parameter | Immediately |
| Pn19F | 0 | | | | | Less-Deviation Control 2 Torque Feedforward Moving Average Time | Immediately |
| Pn1A4 | 36 | | | | | Reserved parameter | Immediately |
| Pn1A5 | 0 | | | | | Reserved parameter | Immediately |
| Pn1AE | 0 | | | | | Reserved parameter | Immediately |
| Pn1AF | 0 | | | | | Reserved parameter | Immediately |
| Pn205 | 65535 | | | | | Multiturn Limit | After restart |

Continued on next page.

5.2.4 Parameter Recording Table

Continued from previous page.

| Parameter No. | Default Setting | | | | Name | When Enabled |
|---------------|-----------------|--|--|--|---|---------------|
| Pn207 | 1000h | | | | Position Control Function Selections | After restart |
| Pn20A | 32768 | | | | Number of External Scale Pitches | After restart |
| Pn20E | 16 | | | | Electronic Gear Ratio (Numerator) | After restart |
| Pn210 | 1 | | | | Electronic Gear Ratio (Denominator) | After restart |
| Pn212 | 2048 | | | | Number of Encoder Output Pulses | After restart |
| Pn22A | 0000h | | | | Fully-closed Control Selections | After restart |
| Pn230 | 0000h | | | | Position Control Expansion Function Selections | After restart |
| Pn231 | 0 | | | | Backlash Compensation | Immediately |
| Pn233 | 0 | | | | Backlash Compensation Time Constant | Immediately |
| Pn234 | 0 | | | | Second Position Reference Acceleration/Deceleration Time Constant | Immediately |
| Pn281 | 20 | | | | Encoder Output Resolution | After restart |
| Pn282 | 0 | | | | Linear Encoder Scale Pitch | After restart |
| Pn304 | 500 | | | | Jogging Speed | Immediately |
| Pn305 | 0 | | | | Soft Start Acceleration Time | Immediately |
| Pn306 | 0 | | | | Soft Start Deceleration Time | Immediately |
| Pn308 | 0 | | | | Speed Feedback Filter Time Constant | Immediately |
| Pn30A | 0 | | | | Deceleration Time for Servo OFF and Forced Stops | Immediately |
| Pn30C | 0 | | | | Speed Feedforward Average Movement Time | Immediately |
| Pn310 | 0000h | | | | Vibration Detection Selections | Immediately |
| Pn311 | 100 | | | | Vibration Detection Sensitivity | Immediately |
| Pn312 | 50 | | | | Vibration Detection Level | Immediately |
| Pn316 | 10000 | | | | Maximum Motor Speed | After restart |
| Pn324 | 300 | | | | Moment of Inertia Calculation Starting Level | Immediately |
| Pn383 | 50 | | | | Jogging Speed | Immediately |
| Pn384 | 10 | | | | Vibration Detection Level | Immediately |
| Pn385 | 50 | | | | Maximum Motor Speed | After restart |
| Pn401 | 100 | | | | First Stage First Torque Reference Filter Time Constant | Immediately |
| Pn402 | 800 | | | | Forward Torque Limit | Immediately |
| Pn403 | 800 | | | | Reverse Torque Limit | Immediately |
| Pn404 | 100 | | | | Forward External Torque Limit | Immediately |
| Pn405 | 100 | | | | Reverse External Torque Limit | Immediately |
| Pn406 | 800 | | | | Emergency Stop Torque | Immediately |

Continued on next page.

Continued from previous page.

| Parameter No. | Default Setting | | | | Name | When Enabled |
|---------------|-----------------|--|--|--|--|--------------|
| Pn407 | 10000 | | | | Speed Limit during Torque Control | Immediately |
| Pn408 | 0000h | | | | Torque-Related Function Selections | *1 |
| Pn409 | 5000 | | | | First Stage Notch Filter Frequency | Immediately |
| Pn40A | 70 | | | | First Stage Notch Filter Q Value | Immediately |
| Pn40B | 0 | | | | First Stage Notch Filter Depth | Immediately |
| Pn40C | 5000 | | | | Second Stage Notch Filter Frequency | Immediately |
| Pn40D | 70 | | | | Second Stage Notch Filter Q Value | Immediately |
| Pn40E | 0 | | | | Second Stage Notch Filter Depth | Immediately |
| Pn40F | 5000 | | | | Second Stage Second Torque Reference Filter Frequency | Immediately |
| Pn410 | 50 | | | | Second Stage Second Torque Reference Filter Q Value | Immediately |
| Pn412 | 100 | | | | First Stage Second Torque Reference Filter Time Constant | Immediately |
| Pn416 | 0000h | | | | Torque-Related Function Selections 2 | Immediately |
| Pn417 | 5000 | | | | Third Stage Notch Filter Frequency | Immediately |
| Pn418 | 70 | | | | Third Stage Notch Filter Q Value | Immediately |
| Pn419 | 0 | | | | Third Stage Notch Filter Depth | Immediately |
| Pn41A | 5000 | | | | Fourth Stage Notch Filter Frequency | Immediately |
| Pn41B | 70 | | | | Fourth Stage Notch Filter Q Value | Immediately |
| Pn41C | 0 | | | | Fourth Stage Notch Filter Depth | Immediately |
| Pn41D | 5000 | | | | Fifth Stage Notch Filter Frequency | Immediately |
| Pn41E | 70 | | | | Fifth Stage Notch Filter Q Value | Immediately |
| Pn41F | 0 | | | | Fifth Stage Notch Filter Depth | Immediately |
| Pn423 | 0000h | | | | Speed Ripple Compensation Selections | *1 |
| Pn424 | 50 | | | | Torque Limit at Main Circuit Voltage Drop | Immediately |
| Pn425 | 100 | | | | Release Time for Torque Limit at Main Circuit Voltage Drop | Immediately |
| Pn426 | 0 | | | | Torque Feedforward Average Movement Time | Immediately |
| Pn427 | 0 | | | | Speed Ripple Compensation Enable Speed | Immediately |

Continued on next page.

5.2 SERVOPACKs with MECHATROLINK-III Communications References

5.2.4 Parameter Recording Table

Continued from previous page.

| Parameter No. | Default Setting | | | | Name | When Enabled |
|---------------|-----------------|--|--|--|---|---------------|
| Pn456 | 15 | | | | Sweep Torque Reference Amplitude | Immediately |
| Pn460 | 0101h | | | | Notch Filter Adjustment Selections 1 | Immediately |
| Pn475 | 0000h | | | | Gravity Compensation-Related Selections | After restart |
| Pn476 | 0 | | | | Gravity Compensation Torque | Immediately |
| Pn480 | 10000 | | | | Speed Limit during Force Control | Immediately |
| Pn481 | 400 | | | | Polarity Detection Speed Loop Gain | Immediately |
| Pn482 | 3000 | | | | Polarity Detection Speed Loop Integral Time Constant | Immediately |
| Pn483 | 30 | | | | Forward Force Limit | Immediately |
| Pn484 | 30 | | | | Reverse Force Limit | Immediately |
| Pn485 | 20 | | | | Polarity Detection Reference Speed | Immediately |
| Pn486 | 25 | | | | Polarity Detection Reference Acceleration/Deceleration Time | Immediately |
| Pn487 | 0 | | | | Polarity Detection Constant Speed Time | Immediately |
| Pn488 | 100 | | | | Polarity Detection Reference Waiting Time | Immediately |
| Pn48E | 10 | | | | Polarity Detection Range | Immediately |
| Pn490 | 100 | | | | Polarity Detection Load Level | Immediately |
| Pn495 | 100 | | | | Polarity Detection Confirmation Force Reference | Immediately |
| Pn498 | 10 | | | | Polarity Detection Allowable Error Range | Immediately |
| Pn49F | 0 | | | | Speed Ripple Compensation Enable Speed | Immediately |
| Pn502 | 20 | | | | Rotation Detection Level | Immediately |
| Pn503 | 10 | | | | Speed Coincidence Detection Signal Output Width | Immediately |
| Pn506 | 0 | | | | Brake Reference-Servo OFF Delay Time | Immediately |
| Pn507 | 100 | | | | Brake Reference Output Speed Level | Immediately |
| Pn508 | 50 | | | | Servo OFF-Brake Command Waiting Time | Immediately |
| Pn509 | 20 | | | | Momentary Power Interruption Hold Time | Immediately |
| Pn50A | 1881h | | | | Input Signal Selections 1 | After restart |
| Pn50B | 8882h | | | | Input Signal Selections 2 | After restart |
| Pn50E | 0000h | | | | Output Signal Selections 1 | After restart |
| Pn50F | 0100h | | | | Output Signal Selections 2 | After restart |
| Pn510 | 0000h | | | | Output Signal Selections 3 | After restart |
| Pn511 | 6543h | | | | Input Signal Selections 5 | After restart |
| Pn512 | 0000h | | | | Output Signal Inverse Settings | After restart |
| Pn514 | 0000h | | | | Output Signal Selections 4 | After restart |

Continued on next page.

Continued from previous page.

| Parameter No. | Default Setting | | | | Name | When Enabled |
|---------------|-----------------|--|--|--|--|---------------|
| Pn516 | 8888h | | | | Input Signal Selections 7 | After restart |
| Pn51B | 1000 | | | | Motor-Load Position Deviation Overflow Detection Level | Immediately |
| Pn51E | 100 | | | | Position Deviation Overflow Warning Level | Immediately |
| Pn520 | 5242880 | | | | Position Deviation Overflow Alarm Level | Immediately |
| Pn522 | 7 | | | | Positioning Completed Width | Immediately |
| Pn524 | 1073741824 | | | | Near Signal Width | Immediately |
| Pn526 | 5242880 | | | | Position Deviation Overflow Alarm Level at Servo ON | Immediately |
| Pn528 | 100 | | | | Position Deviation Overflow Warning Level at Servo ON | Immediately |
| Pn529 | 10000 | | | | Speed Limit Level at Servo ON | Immediately |
| Pn52A | 20 | | | | Multiplier per Fully-closed Rotation | Immediately |
| Pn52B | 20 | | | | Overload Warning Level | Immediately |
| Pn52C | 100 | | | | Base Current Derating at Motor Overload Detection | After restart |
| Pn530 | 0000h | | | | Program Jogging-Related Selections | Immediately |
| Pn531 | 32768 | | | | Program Jogging Travel Distance | Immediately |
| Pn533 | 500 | | | | Program Jogging Movement Speed | Immediately |
| Pn534 | 100 | | | | Program Jogging Acceleration/Deceleration Time | Immediately |
| Pn535 | 100 | | | | Program Jogging Waiting Time | Immediately |
| Pn536 | 1 | | | | Program Jogging Number of Movements | Immediately |
| Pn550 | 0 | | | | Analog Monitor 1 Offset Voltage | Immediately |
| Pn551 | 0 | | | | Analog Monitor 2 Offset Voltage | Immediately |
| Pn552 | 100 | | | | Analog Monitor 1 Magnification | Immediately |
| Pn553 | 100 | | | | Analog Monitor 2 Magnification | Immediately |
| Pn55A | 1 | | | | Power Consumption Monitor Unit Time | Immediately |
| Pn560 | 400 | | | | Residual Vibration Detection Width | Immediately |
| Pn561 | 100 | | | | Overshoot Detection Level | Immediately |
| Pn581 | 20 | | | | Zero Speed Level | Immediately |
| Pn582 | 10 | | | | Speed Coincidence Detection Signal Output Width | Immediately |
| Pn583 | 10 | | | | Brake Reference Output Speed Level | Immediately |
| Pn584 | 10000 | | | | Speed Limit Level at Servo ON | Immediately |

Continued on next page.

5.2.4 Parameter Recording Table

Continued from previous page.

| Parameter No. | Default Setting | | | | Name | When Enabled |
|---------------|-----------------|--|--|--|--|---------------------------|
| Pn585 | 50 | | | | Program Jogging Movement Speed | Immediately |
| Pn586 | 0 | | | | Motor Running Cooling Ratio | Immediately |
| Pn587 | 0000h | | | | Polarity Detection Execution Selection for Absolute Linear Encoder | Immediately |
| Pn600 | 0 | | | | Regenerative Resistor Capacity | Immediately |
| Pn601 | 0 | | | | Dynamic Brake Resistor Allowable Energy Consumption | After restart |
| Pn603 | 0 | | | | Regenerative Resistance | Immediately |
| Pn604 | 0 | | | | Dynamic Brake Resistance | After restart |
| Pn61A | 0000h | | | | Overheat Protection Selections | After restart |
| Pn61B | 250 | | | | Overheat Alarm Level | Immediately |
| Pn61C | 100 | | | | Overheat Warning Level | Immediately |
| Pn61D | 0 | | | | Overheat Alarm Filter Time | Immediately |
| Pn800 | 1040h | | | | Communications Controls | Immediately |
| Pn801 | 0003h | | | | Application Function Selections 6 (Software Limits) | Immediately |
| Pn803 | 10 | | | | Origin Range | Immediately |
| Pn804 | 1073741823 | | | | Forward Software Limit | Immediately |
| Pn806 | -1073741823 | | | | Reverse Software Limit | Immediately |
| Pn808 | 0 | | | | Absolute Encoder Origin Offset | Immediately ^{*2} |
| Pn80A | 100 | | | | First Stage Linear Acceleration Constant | Immediately ^{*3} |
| Pn80B | 100 | | | | Second Stage Linear Acceleration Constant | Immediately ^{*3} |
| Pn80C | 0 | | | | Acceleration Constant Switching Speed | Immediately ^{*3} |
| Pn80D | 100 | | | | First Stage Linear Deceleration Constant | Immediately ^{*3} |
| Pn80E | 100 | | | | Second Stage Linear Deceleration Constant | Immediately ^{*3} |
| Pn80F | 0 | | | | Deceleration Constant Switching Speed | Immediately ^{*3} |
| Pn810 | 0 | | | | Exponential Acceleration/Deceleration Bias | Immediately ^{*3} |
| Pn811 | 0 | | | | Exponential Acceleration/Deceleration Time Constant | Immediately ^{*3} |
| Pn812 | 0 | | | | Movement Average Time | Immediately ^{*3} |
| Pn814 | 100 | | | | External Positioning Final Travel Distance | Immediately ^{*3} |
| Pn816 | 0000h | | | | Origin Return Mode Settings | Immediately ^{*3} |
| Pn817 | 50 | | | | Origin Approach Speed 1 | Immediately ^{*3} |
| Pn818 | 5 | | | | Origin Approach Speed 2 | Immediately ^{*3} |

Continued on next page.

Continued from previous page.

| Parameter No. | Default Setting | | | | | Name | When Enabled |
|---------------|-----------------|--|--|--|--|--|---------------------------|
| Pn819 | 100 | | | | | Final Travel Distance for Origin Return | Immediately ^{*3} |
| Pn81E | 0000h | | | | | Input Signal Monitor Selections | Immediately |
| Pn81F | 0010h | | | | | Command Data Allocations | After restart |
| Pn820 | 0 | | | | | Forward Latching Area | Immediately |
| Pn822 | 0 | | | | | Reverse Latching Area | Immediately |
| Pn824 | 0000h | | | | | Option Monitor 1 Selection | Immediately |
| Pn825 | 0000h | | | | | Option Monitor 2 Selection | Immediately |
| Pn827 | 100 | | | | | Linear Deceleration Constant 1 for Stopping | Immediately ^{*3} |
| Pn829 | 0 | | | | | SVOFF Waiting Time (for SVOFF at Deceleration to Stop) | Immediately |
| Pn82A | 1813h | | | | | Option Field Allocations 1 | After restart |
| Pn82B | 1D1Ch | | | | | Option Field Allocations 2 | After restart |
| Pn82C | 1F1Eh | | | | | Option Field Allocations 3 | After restart |
| Pn82D | 0000h | | | | | Option Field Allocations 4 | After restart |
| Pn82E | 0000h | | | | | Option Field Allocations 5 | After restart |
| Pn833 | 0000h | | | | | Motion Settings | After restart |
| Pn834 | 100 | | | | | First Stage Linear Acceleration Constant 2 | Immediately ^{*3} |
| Pn836 | 100 | | | | | Second Stage Linear Acceleration Constant 2 | Immediately ^{*3} |
| Pn838 | 0 | | | | | Acceleration Constant Switching Speed 2 | Immediately ^{*3} |
| Pn83A | 100 | | | | | First Stage Linear Deceleration Constant 2 | Immediately ^{*3} |
| Pn83C | 100 | | | | | Second Stage Linear Deceleration Constant 2 | Immediately ^{*3} |
| Pn83E | 0 | | | | | Deceleration Constant Switching Speed 2 | Immediately ^{*3} |
| Pn840 | 100 | | | | | Linear Deceleration Constant 2 for Stopping | Immediately ^{*3} |
| Pn842 | 0 | | | | | Second Origin Approach Speed 1 | Immediately ^{*3} |
| Pn844 | 0 | | | | | Second Origin Approach Speed 2 | Immediately ^{*3} |
| Pn846 | 0 | | | | | POSING Command Scurve Acceleration/Deceleration Rate | Immediately ^{*3} |
| Pn850 | 0 | | | | | Number of Latch Sequences | Immediately |
| Pn851 | 0 | | | | | Continuous Latch Sequence Count | Immediately |
| Pn852 | 0000h | | | | | Latch Sequence 1 to 4 Settings | Immediately |
| Pn853 | 0000h | | | | | Latch Sequence 5 to 8 Settings | Immediately |
| Pn860 | 0000h | | | | | SVCMD_IO Input Signal Monitor Allocations 1 | Immediately |
| Pn861 | 0000h | | | | | SVCMD_IO Input Signal Monitor Allocations 2 | Immediately |

Continued on next page.

Continued from previous page.

| Parameter No. | Default Setting | | | | Name | When Enabled |
|----------------|-----------------|--|--|--|---|---------------|
| Pn862 | 0000h | | | | SVCMD_IO Input Signal Monitor Allocations 3 | Immediately |
| Pn863 | 0000h | | | | SVCMD_IO Input Signal Monitor Allocations 4 | Immediately |
| Pn868 | 0000h | | | | SVCMD_IO Output Signal Monitor Allocations 1 | Immediately |
| Pn869 | 0000h | | | | SVCMD_IO Output Signal Monitor Allocations 2 | Immediately |
| Pn880 | – | | | | Station Address Monitor (for maintenance, read only) | Immediately |
| Pn881 | – | | | | Set Transmission Byte Count Monitor [bytes] (for maintenance, read only) | Immediately |
| Pn882 | – | | | | Transmission Cycle Setting Monitor [$\times 0.25 \mu\text{s}$] (for maintenance, read only) | Immediately |
| Pn883 | – | | | | Communications Cycle Setting Monitor [transmission cycles] (for maintenance, read only) | Immediately |
| Pn884 | 0000h | | | | Communications Controls 2 | Immediately |
| Pn88A | 0 | | | | MECHATROLINK Receive Error Counter Monitor (for maintenance, read only) | Immediately |
| Pn890 to Pn8A6 | 0h | | | | Command Data Monitor during Alarm/Warning (for maintenance, read only) | Immediately |
| Pn8A8 to Pn8BE | 0h | | | | Response Data Monitor during Alarm/Warning (for maintenance, read only) | Immediately |
| Pn900 | 0 | | | | Number of Parameter Banks | After restart |
| Pn901 | 0 | | | | Number of Parameter Bank Members | After restart |
| Pn902 to Pn910 | 0000h | | | | Parameter Bank Member Definition | After restart |
| Pn920 to Pn95F | 0000h | | | | Parameter Bank Data (Not saved in nonvolatile memory.) | Immediately |
| 01 PnA02 | – | | | | Encoder Type Selection (read only) | – |
| 02 PnA04 | – | | | | Motor Type Selection (read only) | – |
| 03 PnA06 | – | | | | Semi-closed/Fully-closed Selection (read only) | – |
| 04 PnA08 | – | | | | Rated Motor Speed (read only) | – |
| 05 PnA0A | – | | | | Maximum Output Speed (read only) | – |
| 06 PnA0C | – | | | | Speed Multiplier (read only) | – |
| 07 PnA0E | – | | | | Rated Torque (read only) | – |

Continued on next page.

Continued from previous page.

| Parameter No. | Default Setting | | | | | Name | When Enabled |
|---------------|-----------------|--|--|--|--|-------------------------------------|---------------|
| 08 PnA10 | – | | | | | Maximum Output Torque (read only) | – |
| 09 PnA12 | – | | | | | Torque Multiplier (read only) | – |
| 0A PnA14 | – | | | | | Resolution (read only) | – |
| 0B PnA16 | 0 | | | | | Scale Pitch | After restart |
| 0C PnA18 | – | | | | | Pulses per Scale Pitch (read only) | – |
| 21 PnA42 | 16 | | | | | Electronic Gear Ratio (Numerator) | After restart |
| 22 PnA44 | 1 | | | | | Electronic Gear Ratio (Denominator) | After restart |
| 23 PnA46 | 0 | | | | | Absolute Encoder Origin Offset | Immediately*2 |
| 24 PnA48 | 65535 | | | | | Multiturn Limit Setting | After restart |
| 25 PnA4A | 0000h | | | | | Limit Setting | After restart |
| 26 PnA4C | 1073741823 | | | | | Forward Software Limit | Immediately |
| 27 PnA4E | 0 | | | | | Reserved parameter (Do not change.) | Immediately |
| 28 PnA50 | -1073741823 | | | | | Reverse Software Limit | Immediately |
| 29 PnA52 | 0 | | | | | Reserved parameter (Do not change.) | Immediately |
| 41 PnA82 | 0h | | | | | Speed Unit Selection | After restart |
| 42 PnA84 | 0 | | | | | Speed Base Unit Selection | After restart |
| 43 PnA86 | 0h | | | | | Position Unit Selection | After restart |
| 44 PnA88 | 0 | | | | | Position Base Unit Selection | After restart |
| 45 PnA8A | 0h | | | | | Acceleration Unit Selection | After restart |
| 46 PnA8C | 4 | | | | | Acceleration Base Unit Selection | After restart |
| 47 PnA8E | 1h | | | | | Torque Unit Selection | After restart |
| 48 PnA90 | 0 | | | | | Torque Base Unit Selection | After restart |
| 49 PnA92 | 0601011Fh | | | | | Supported Unit Systems (read only) | – |
| 61 PnAC2 | 40000 | | | | | Speed Loop Gain | Immediately |
| 62 PnAC4 | 20000 | | | | | Speed Loop Integral Time Constant | Immediately |
| 63 PnAC6 | 40000 | | | | | Position Loop Gain | Immediately |
| 64 PnAC8 | 0 | | | | | Feedforward Compensation | Immediately |

Continued on next page.

Continued from previous page.

| Parameter No. | Default Setting | | | | | Name | When Enabled |
|---------------|--|--|--|--|--|---|---------------------------|
| 65 PnACA | 0 | | | | | Position Loop Integral Time Constant | Immediately |
| 66 PnACC | 7 | | | | | Positioning Completed Width | Immediately |
| 67 PnACE | 1073741824 | | | | | Near Signal Width | Immediately |
| 81 PnB02 | 0 | | | | | Exponential Acceleration/ Deceleration Time Constant | Immediately* ³ |
| 82 PnB04 | 0 | | | | | Movement Average Time | Immediately* ³ |
| 83 PnB06 | 100 | | | | | External Positioning Final Travel Distance | Immediately |
| 84 PnB08 | × 5,000h reference units/s converted to 10 ⁻³ min ⁻¹ | | | | | Origin Approach Speed | Immediately |
| 85 PnB0A | × 500h reference units/s converted to 10 ⁻³ min ⁻¹ | | | | | Origin Return Creep Speed | Immediately |
| 86 PnB0C | 100 | | | | | Final Travel Distance for Origin Return | Immediately |
| 87 PnB0E | 1h | | | | | Fixed Monitor Selection 1 | Immediately |
| 88 PnB10 | 0h | | | | | Fixed Monitor Selection 2 | Immediately |
| 89 PnB12 | 0h | | | | | SEL_MON (CMN1) Monitor Selection 1 | Immediately |
| 8A PnB14 | 0h | | | | | SEL_MON (CMN2) Monitor Selection 2 | Immediately |
| 8B PnB16 | 10 | | | | | Origin Detection Width | Immediately |
| 8C PnB18 | 100 | | | | | Forward Torque Limit | Immediately |
| 8D PnB1A | 100 | | | | | Reverse Torque Limit | Immediately |
| 8E PnB1C | 20000 | | | | | Zero Speed Detection Range | Immediately |
| 8F PnB1E | 10000 | | | | | Speed Coincidence Signal Detection Width | Immediately |
| 90 PnB20 | 0FFF3F3Fh | | | | | Servo Command Control Field Enable/Disable Selec- tions (read only) | – |
| 91 PnB22 | 0FFF3F33h | | | | | Servo Status Field Enable/ Disable Selections (read only) | – |
| 92 PnB24 | 007F01F0h | | | | | Output Bit Enable/Disable Selections (read only) | – |
| 93 PnB26 | FF0FFEFeh | | | | | Input Bit Enable/Disable Selections (read only) | – |

*1. The enable timing depends on the digit that is changed. Refer to the following section for details.

 5.2.2 List of Servo Parameters on page 5-45

 5.2.3 List of MECHATROLINK-III Common Parameters on page 5-85

*2. The parameter setting is enabled after SENS_ON command execution is completed.

*3. Change the setting when the reference is stopped (i.e., while DEN is set to 1). If you change the setting during operation, the reference output will be affected.

Index

A

| | |
|---------------------------------------|-------|
| adjustment procedure | -3-12 |
| adjustment procedures | 3-4 |
| advanced autotuning with reference | 1-8 |
| advanced autotuning without reference | 1-8 |
| alarm code output | 4-2 |
| automatic gain switching | 1-8 |

B

| | |
|-----------------|-----|
| base block (BB) | xii |
|-----------------|-----|

C

| | |
|----------------------------------|-------------|
| coefficient of speed fluctuation | -2-10, 2-13 |
|----------------------------------|-------------|

F

| | |
|-------------|-----|
| feedforward | 1-8 |
|-------------|-----|

L

| | |
|------------------------|------------|
| less-deviation control | 3-2 |
| Linear Servomotor | xii |
| list of alarms | 4-2, 4-58 |
| list of parameters | 5-2, 5-44 |
| list of warnings | 4-39, 4-96 |

M

| | |
|-------------------------|-------------|
| Main Circuit Cable | xii |
| manual gain switching | -3-10, 3-15 |
| model following control | 1-8 |

O

| | |
|----------------------|-----|
| one-parameter tuning | 1-8 |
|----------------------|-----|

P

| | |
|------------------------------------|-------------|
| parameter settings recording table | -5-36, 5-93 |
| parameters | |
| notation (numeric settings) | xiii |
| notation (selecting functions) | xiii |

R

| | |
|-------------------|-----|
| Rotary Servomotor | xii |
|-------------------|-----|

S

| | |
|--------------------|-----|
| Servo Drive | xii |
| servo lock | xii |
| servo OFF | xii |
| servo ON | xii |
| Servo System | xii |
| Servomotor | xii |
| SERVOPACK | xii |
| model designations | 1-3 |
| specifications | 2-6 |

| | |
|-----------------------------|-----------|
| SigmaWin+ | -xii |
| storage humidity | 2-6, 2-10 |
| storage temperature | 2-6, 2-10 |
| surrounding air humidity | 2-6, 2-10 |
| surrounding air temperature | 2-6, 2-10 |

T

| | |
|---------------------------|------------|
| troubleshooting alarms | 4-9, 4-64 |
| troubleshooting warnings | 4-40, 4-98 |
| tuning-less function | 1-8 |
| tuning-less level setting | 1-8 |

V

| | |
|-----------------------|-----|
| vibration suppression | 1-8 |
|-----------------------|-----|

W

| | |
|---------------------|------|
| warning code output | 4-39 |
|---------------------|------|

Revision History

The revision dates and numbers of the revised manuals are given on the bottom of the back cover.

MANUAL NO. SIEP S800001 89B <1>-0
 Published in Japan February 2017

┌─── Web revision number
 └─── Revision number
 └─── Date of publication

| Date of Publication | Rev. No. | Web Rev. No. | Section | Revised Contents |
|---------------------|----------|--------------|----------------------------|--|
| February 2020 | <5> | 0 | Preface | Partly revised. |
| | | | Back cover | Revision: Address |
| October 2019 | <4> | 0 | Preface, chapters 1, 4, 5 | Partly revised. |
| | | | Back cover | Revision: Address |
| September 2018 | <3> | 0 | All chapters | Partially revised. |
| | | | 2.1.1 | Revision: Built-in regenerative resistor power loss for SGD7S-120A, -180A, -200A |
| | | | 4.1.2, 4.1.3, 4.2.2, 4.2.3 | Deletion: A.F50 |
| | | | Back cover | Revision: Address |
| November 2017 | <2> | 0 | All chapters | Partly revised. |
| July 2017 | <1> | 1 | Preface | Revision: Information on certification for standards |
| | | | Back cover | Revision: Address |
| February 2017 | | 0 | All chapters | Partially revised. Addition: Information on SERVOPACKs with single-phase, 100-VAC power supply inputs |
| | | | Back cover | Revision: Address |
| September 2015 | - | - | - | First edition |
| | | | - | Based on Japanese product manual, SIJP S800001 89A<0>-1, published in August 2015. |

Σ-7-Series AC Servo Drive

Σ-7S SERVOPACK with FT/EX Specification for Tracking Application

Product Manual

IRUMA BUSINESS CENTER (SOLUTION CENTER)

480, Kamifujisawa, Iruma, Saitama, 358-8555, Japan
Phone: +81-4-2962-5151 Fax: +81-4-2962-6138
www.yaskawa.co.jp

YASKAWA AMERICA, INC.

2121, Norman Drive South, Waukegan, IL 60085, U.S.A.
Phone: +1-800-YASKAWA (927-5292) or +1-847-887-7000 Fax: +1-847-887-7310
www.yaskawa.com

YASKAWA ELÉTRICO DO BRASIL LTDA.

777, Avenida Piraporinha, Diadema, São Paulo, 09950-000, Brasil
Phone: +55-11-3585-1100 Fax: +55-11-3585-1187
www.yaskawa.com.br

YASKAWA EUROPE GmbH

Hauptstraße 185, 65760 Eschborn, Germany
Phone: +49-6196-569-300 Fax: +49-6196-569-398
www.yaskawa.eu.com E-mail: info@yaskawa.eu.com

YASKAWA ELECTRIC KOREA CORPORATION

35F, Three IFC, 10 Gukjegeumyung-ro, Yeongdeungpo-gu, Seoul, 07326, Korea
Phone: +82-2-784-7844 Fax: +82-2-784-8495
www.yaskawa.co.kr

YASKAWA ASIA PACIFIC PTE. LTD.

30A, Kallang Place, #06-01, 339213, Singapore
Phone: +65-6282-3003 Fax: +65-6289-3003
www.yaskawa.com.sg

YASKAWA ELECTRIC (THAILAND) CO., LTD.

59, 1F-5F, Flourish Building, Soi Ratchadapisek 18, Ratchadapisek Road, Huaykwang, Bangkok, 10310, Thailand
Phone: +66-2-017-0099 Fax: +66-2-017-0799
www.yaskawa.co.th

YASKAWA ELECTRIC (CHINA) CO., LTD.

22F, Link Square 1, No.222, Hubin Road, Shanghai, 200021, China
Phone: +86-21-5385-2200 Fax: +86-21-5385-3299
www.yaskawa.com.cn

YASKAWA ELECTRIC (CHINA) CO., LTD. BEIJING OFFICE

Room 1011, Tower W3 Oriental Plaza, No.1, East Chang An Avenue,
Dong Cheng District, Beijing, 100738, China
Phone: +86-10-8518-4086 Fax: +86-10-8518-4082

YASKAWA ELECTRIC TAIWAN CORPORATION

12F, No. 207, Section 3, Beishin Road, Shindian District, New Taipei City 23143, Taiwan
Phone: +886-2-8913-1333 Fax: +886-2-8913-1513 or +886-2-8913-1519
www.yaskawa.com.tw

YASKAWA

YASKAWA ELECTRIC CORPORATION

In the event that the end user of this product is to be the military and said product is to be employed in any weapons systems or the manufacture thereof, the export will fall under the relevant regulations as stipulated in the Foreign Exchange and Foreign Trade Regulations. Therefore, be sure to follow all procedures and submit all relevant documentation according to any and all rules, regulations and laws that may apply.

Specifications are subject to change without notice for ongoing product modifications and improvements.

© 2015 YASKAWA ELECTRIC CORPORATION

MANUAL NO. SIEP S800001 89F <5>-0

Published in Japan February 2020

19-10-16

Original instructions